

CAT® UNDERCARRIAGE

ALL THE RIGHT CHOICES

Optimizing the value of your small and medium track machines with undercarriage options designed to match your applications and underfoot conditions.



CARRYING ON THE COMMITMENT

Nearly 100 years after Caterpillar introduced the world's first tracked machine, in 2004 we introduced Cat® SystemOne™ Undercarriage. Our most technologically advanced undercarriage configuration yet, SystemOne delivers the longest life and greatest reliability of any undercarriage system in many applications.

It would be ideal if this single undercarriage solution worked best for all work applications and environments. That would certainly make it easy to choose the right undercarriage for any job. But in reality, machine models, applications and work environments vary, as do packing and impact conditions. So a single undercarriage solution, whether it's SystemOne or another option, simply can't provide optimal value for each and every undercarriage customer.

That's why Caterpillar remains dedicated to constantly improving our products so we can continue to offer you enhanced undercarriage options that maximize your machine investments. The enhanced undercarriage options are designed to work best for specific applications and environments that lower your owning and operating costs—and add to your bottom line.



UNDERCARRIAGE SELECTION MATTERS

One of the most important factors in helping you achieve the lowest O&O costs and maximizing equipment uptime is matching the right undercarriage option to your specific machine model and work application.

Your Cat Dealer has the undercarriage knowledge and selection tools to help ensure you choose the best option for your equipment and your job. When consulting with you on options, Dealers use these tools while taking key factors into account to identify your best-fit undercarriage configuration.

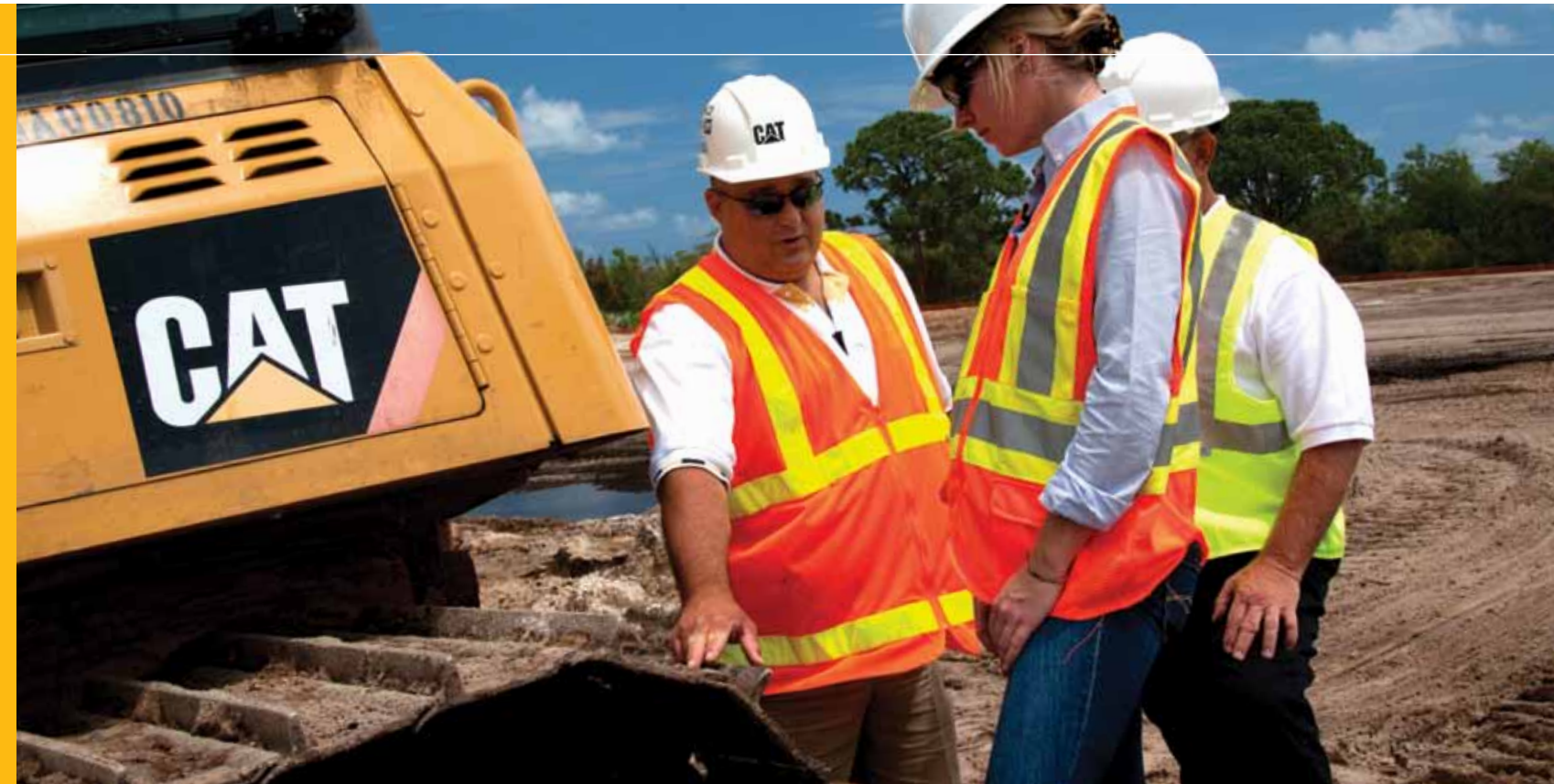

Key Selection Factors to Consider

Track Frame Configuration	Standard, Extended (L) (XL), Extra Wide (XW), Low Ground Pressure (LGP)
Width of Track Shoes	Narrow, intermediate or wide Tri- and Quad-link Track configurations
Type of Track Shoe	Extreme Service (ES), Moderate Service (MS), Self-Cleaning, Center Hole, Chopper
Blade Type	Variable-pitch Power Angle/Tilt (VPAT), Semi-Universal (SU), Angle, Straight
Rear Attachment	Wincher, Ripper, Counterweight, Drawbar
Other Attachments	Sweeps, Window Guarding
Underfoot Conditions	Light, moderate or severe abrasion and impact
Terrain	Side slopes, ground objects and V-ditching
Packing Conditions	Operating in extrusive materials, which can usually be squeezed out from between track parts when wet, e.g., clay soils Operating in non-extrusive materials, which can't be extruded from the link windows and track shoe center holes of most undercarriage tracks, e.g., branches

Cost-per-hour analysis

Dealers also use undercarriage tools to run cost-per-hour scenarios to help determine which undercarriage option is the best fit for your business requirements.

UNDERCARRIAGE APPLICATION GUIDE

Life/Impact Matrix

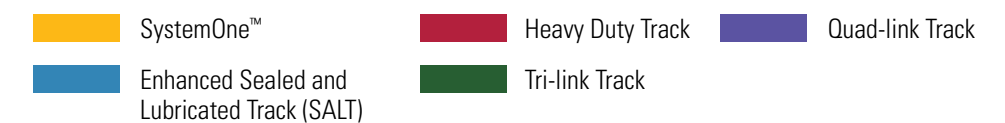
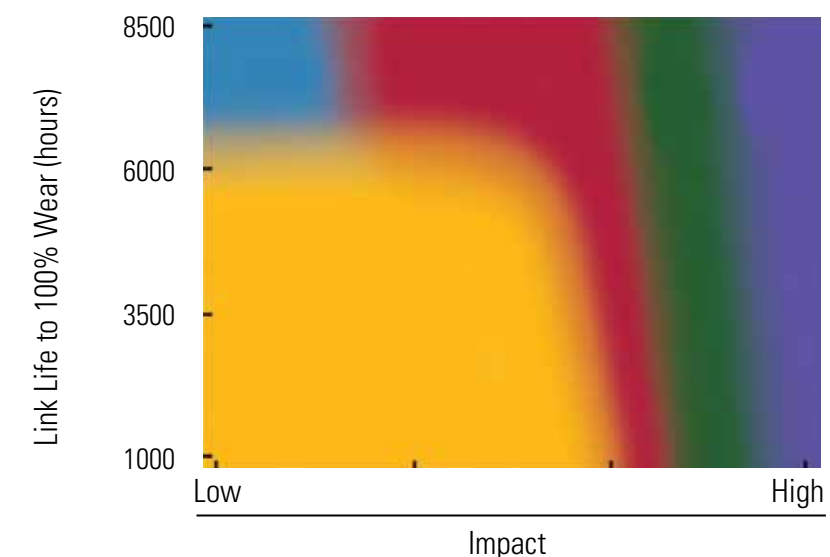

CAT SYSTEMONE UNDERCARRIAGE

THE LEADER IN LOWERING O&O COSTS

The goal behind Cat SystemOne Undercarriage: Develop an extremely durable and reliable undercarriage that works and wears as a system, ensuring a balanced wear life, to significantly lower customers' O&O costs. SystemOne is designed to increase undercarriage uptime and productivity, and a longer service life, while it also reduces maintenance intervals and repair costs.

From its inception, SystemOne has delivered on its goal by routinely cutting customers' O&O costs. But performance success hasn't stopped us from constantly improving SystemOne—to help keep improving your productivity and profitability.



Continuous Improvement

Caterpillar engineers have made many design enhancements to develop the superior SystemOne iron we're using today, particularly in the Link Assemblies. Overall, we have improved our design, manufacturing processes and tools used for application recommendations.

Take a look at these examples of major SystemOne design and manufacturing improvements. And because Caterpillar is committed to continuous improvement, you are assured we'll never stop making SystemOne better for you.

Dry Joint Protection

- Increased the bushing strength to resist bushing cracking
- Redesigned the seal cavity, which allows seals to stay in their correct position and defends against the seal rolling under and packing
- Incorporated harder cartridge inserts to minimize endplay generation and thrust ring damage, which keeps oil where it belongs

Seal Exposure Reduction

- Changed to a slightly angled Cambered Pivot Shaft to reduce thrust bias wear and provide better track alignment and less seal exposure throughout the life of the system
- Added a Relieved Tread Idler (RTI) to better resist thrust wear and reduce material packing in the track seal cavity

Idler and Sprocket Life

- As in the original design, idler and sprocket segments are manufactured for reuse, so they typically last for up to two track systems (varying by model, application and underfoot conditions)

1 Guards cover the areas between the front idler and first roller and the rear idler and rear roller to help keep material out of the undercarriage system to reduce packing. Different guard options are available for the various packing conditions machines operate in, including extreme packing environments.

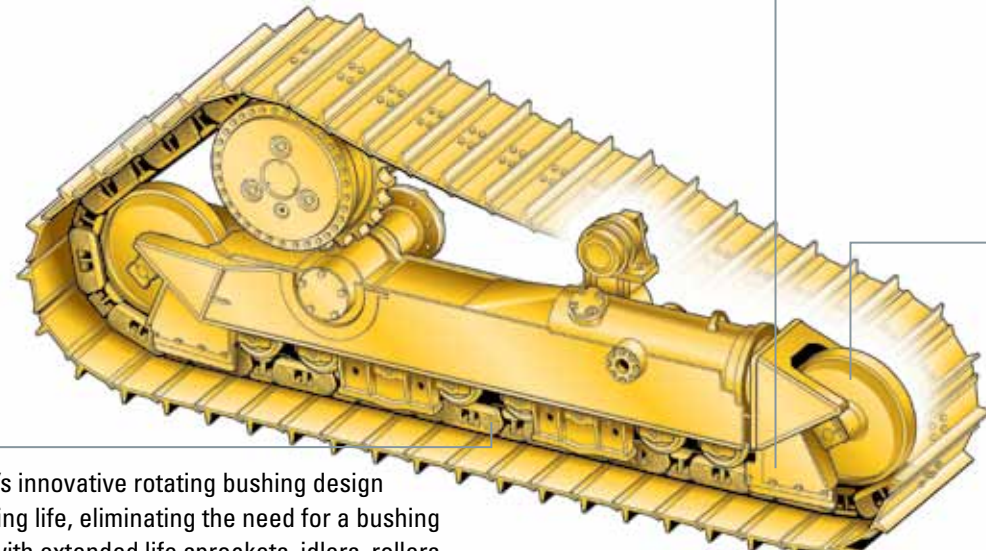

3 Cat SystemOne's innovative rotating bushing design increases bushing life, eliminating the need for a bushing turn. Together with extended life sprockets, idlers, rollers and cartridges, the life of the entire system is extended. The net effect is improved productivity at a dramatically lower cost.

2 SystemOne's center tread idlers eliminate costly link rail scalloping and provide the link assembly with more guiding. The result: A smoother and more productive work environment for your operators—and a longer undercarriage system life.

CAT SEALED AND LUBRICATED TRACK (SALT)

OPTIONS THAT FIT YOUR WORK

Cat Sealed and Lubricated Track (SALT) seals lubricant into your undercarriage system and keeps abrasives out. It virtually eliminates internal pin and bushing wear to reduce maintenance costs and downtime, while increasing service life and serviceability.

Cat SALT offers you a universal undercarriage configuration for a wide range of underfoot conditions when coupled with the track design that matches your machine and operating environment.

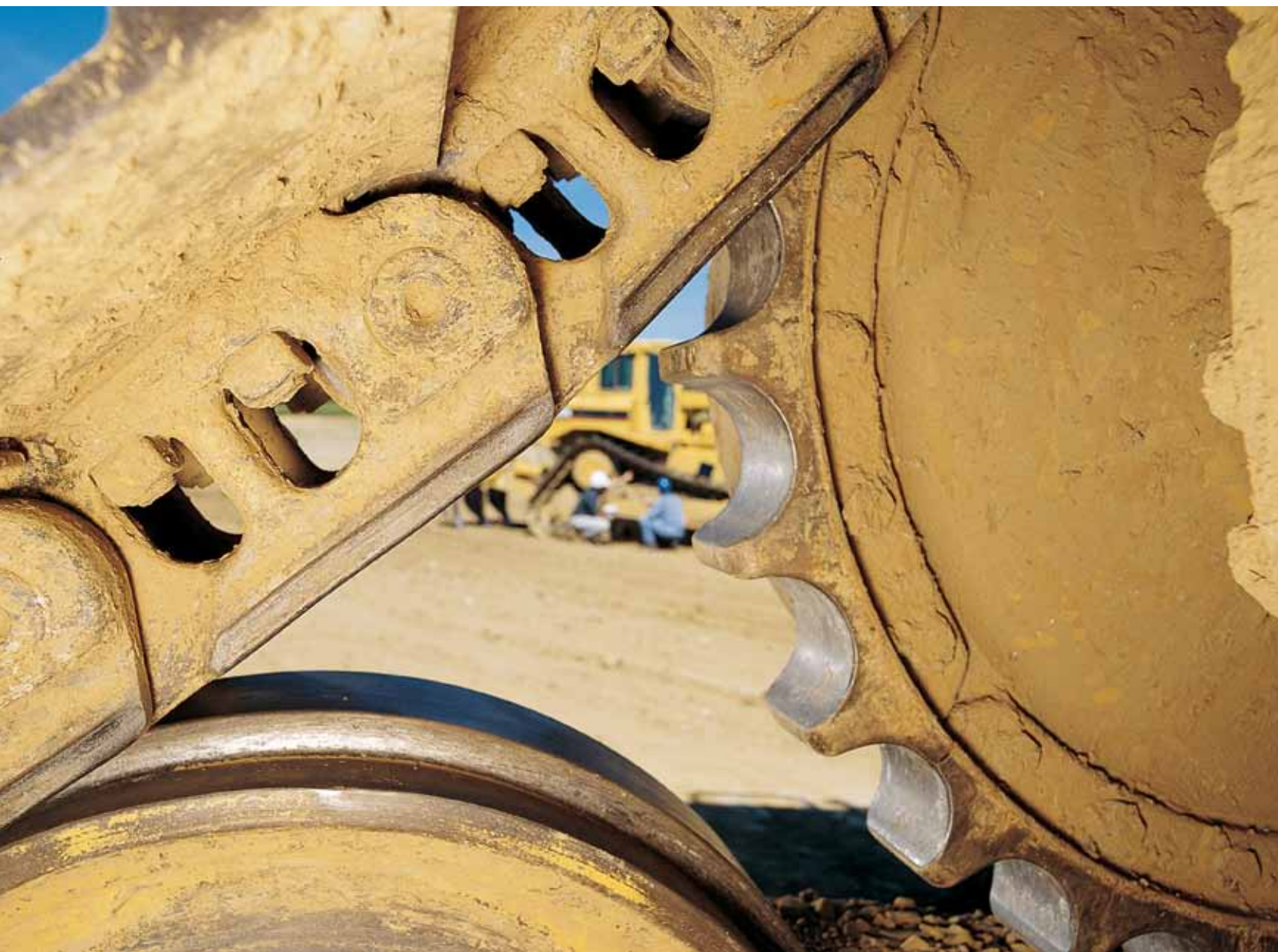

Track Design Variations

Enhanced SALT Track

Designed specifically for D6, D7 and Track Loader models, Cat Enhanced SALT Track offers better pin and bushing retention for improved sealability and spalling resistance on oval tracks. With its tall link design, Enhanced SALT Track increases wear life and minimizes operating costs.

Heavy Duty Track (HD)

Engineered to match the requirements of medium size machines with an elevated sprocket (D6N, D6T) operating in demanding work environments, Heavy Duty Track features stronger links, pins and bushings that significantly offset the effects of high-impact loads and stresses to extend system wear life.

Positive Pin Retention Track (PPR)

The standard track for D8 to D11 models, PPR Track was designed for high-impact applications, such as mining, heavy construction, demolition and waste. The metal retaining rings on PPR Track help eliminate end-play and “pin walking.” The rings also ensure a good fit between seal and bushing, which helps keep lubricant in the track to reduce galling.

Enhancements Reduce O&O Costs

Since introducing SALT in 1974, Caterpillar has consistently enhanced its design to meet the specific needs of your applications. Each track component has undergone and continues to undergo our stringent improvement process so your undercarriage will work harder for you.

As a result, SALT offers major advantages, all of which add up to longer wear life—and reduced O&O costs for you.

- Sophisticated heat-treat processes ensure track links have high core hardness, helping to hold the track section together and preventing leaks caused by links “walking off” the pin.
- Cross-drilled pins provide an oil passage between the pin and the bushing. Carefully machined oil reservoirs ensure proper oil distribution.
- Polished bushing ends prevent accelerated seal lip wear. Stepped bushings, which are thicker in the middle, provide more external wear material.
- Rigid seal, which consists of a flexible load ring, rigid seal ring and thrust ring, provides better sealability in all underfoot conditions, reducing the effects of impact on track joints that can cause premature seal failure.

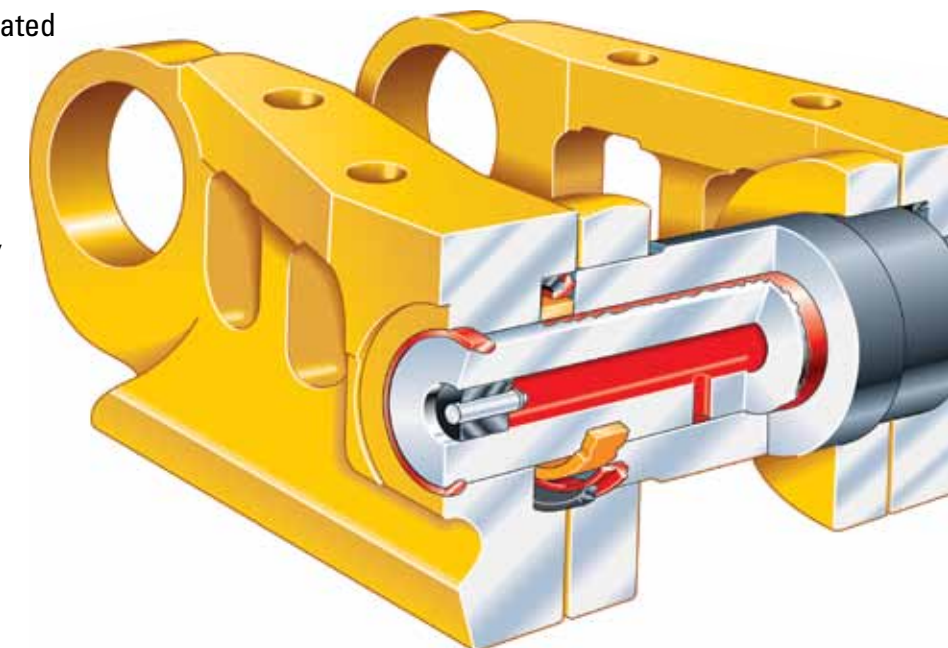

CAT HEAVY DUTY TRACK

TOUGH TRACK FOR TOUGH JOBS

Specifically engineered to match the requirements of medium size machines with an elevated sprocket operating in demanding work environments, Cat Heavy Duty Track is much more than just another version of conventional Cat Sealed and Lubricated Track (SALT).

In most tough underfoot conditions, Heavy Duty Track can extend your undercarriage system life an average of 20 percent more than Cat SALT, with the greatest benefits realized in aggressive, high-impact applications such as:

- Logging/reforestation
- Side-sloping work
- Rocky conditions
- Any uneven terrain with wide track shoes (specifically Low Ground Pressure (LGP) machines)

Hard-Working Heavy Duty Track

Because it is expressly designed to take on more challenging terrain and work than Enhanced SALT Track undercarriages, Heavy Duty Track features stronger links, pins and bushings that significantly offset the effects of high-impact loads and stresses to extend system wear life—and lower your O&O costs.

Heavy Duty Track Component	Compared to Enhanced SALT Track	Benefit
Link Bushing Strap	65% wider	<ul style="list-style-type: none"> • Greater bushing retention • Increased strength
Link Pin Boss	20% wider	<ul style="list-style-type: none"> • Increased pin retention
Bushing	10% longer	<ul style="list-style-type: none"> • More press fit area • Increased retention
Pin	14% longer	<ul style="list-style-type: none"> • More press fit area • Increased retention

Results may vary based upon application.



CAT TRI-LINK TRACK AND CAT QUAD-LINK TRACK

DESIGNED FOR THE EXTREME

Tri-link Track and Quad-link Track were developed by Caterpillar as undercarriage solution options for the most severe impact conditions. Their unique designs improve link assembly strength by bolting on additional outrigger chains, making them the right choice for logging (skidding), stumping and taking on work in rocky terrains or any application where shoe deflection is high.

Tri-link Track adds one outrigger chain to the outer ends of the track shoes, and Quad-link Track adds two, which greatly improves sealability.

Using Tri-link Track or Quad-link Track in high-impact applications may at first seem more expensive, but the reality is tough tracks typically result in lower undercarriage cost-per-hour because they were designed for extreme conditions and offer you better load distribution, improved lubricated joint life (fewer dry joints) and greater system reliability.

NOTE: Tri-link Track and Quad-link Track are available only with the Heavy Duty Track option.

COMPREHENSIVE SUPPORT

To help you get the most from your Cat Undercarriage, Caterpillar and Cat Dealers also remain dedicated to providing you with global service and support for all undercarriage configuration options—from advanced diagnostics to worldwide parts delivery.



Undercarriage and Wear Life Assurance Programs

Our Undercarriage Assurance Programs were developed to demonstrate our commitment to provide you the lowest cost-per-hour undercarriage systems. Assurance Programs offer you support beyond the standard new machine or parts warranties. They cover all major moving undercarriage components on Cat Track-Type Tractors, Track-Type Loaders and Track-Type Hydraulic Excavators. See your Cat Dealer for full details about coverage for specific undercarriage configuration options.

	Coverage in Years	Coverage in Hours	Coverage in Percent Worn
Genuine	4	4,000	100%
Gold	4	6,000	100%
SystemOne	4	6,000	100%

Custom Track Service (CTS)

An improperly managed undercarriage can account for more than half of machine maintenance costs. That's why we provide Custom Track Service (CTS), our comprehensive program for managing your undercarriage system, which uses the most advanced diagnostic equipment available, like the Ultrasonic Wear Indicator.

With CTS, we can accurately monitor undercarriage performance and predict wear rates, so you can evaluate service options, plan your maintenance and schedule downtime. Overall, CTS analysis, which can be completed on your job site, helps you make informed decisions that keep your operating costs as low as possible.

Worldwide Parts Availability

Our industry-standard parts distribution network makes most new parts available to you anywhere in the world, usually within 24 hours.

Consult with Your Cat Dealer Today

Your Cat Dealer has the undercarriage expertise and selection tools to assist in assessing your undercarriage configuration options. So you'll want to consult with your Dealership to verify which option is the right undercarriage choice for you. The choice that best suits your machine and application, and also offers you the right fit to meet your owning and operating needs.

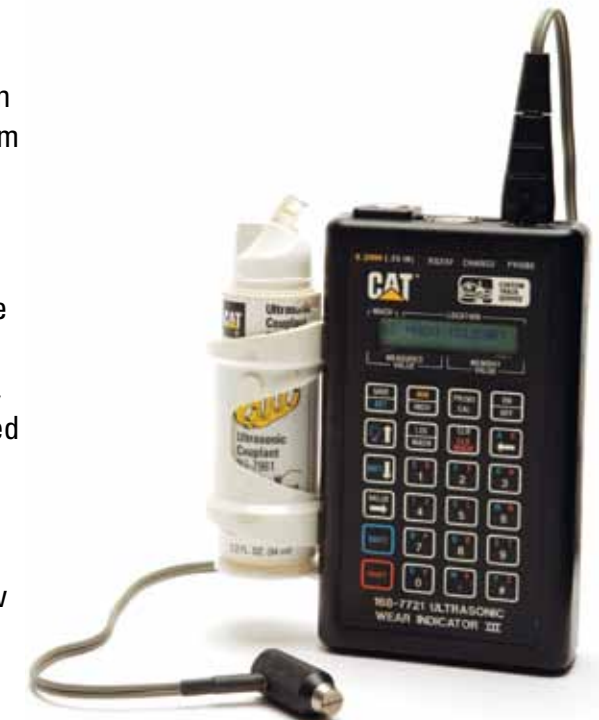



System Availability for Small and Medium Track Machines:

Systems	D3	D4	D5	D6K	D6N	D6T	D8T	953D	963D
Sealed & Lubricated Track (SALT)	•	•	•						
Enhanced SALT Track			•					•	•
SystemOne	•	•		•	•	•	•	•	•
Heavy Duty Track					•	•			
Positive Pin Retention (PPR)							•		
Tri- or Quad-Track					•	•			



PEDJ0100
www.cat.com

© 2011 Caterpillar All Rights Reserved

CAT, CATERPILLAR, their respective logos, SystemOne, "Caterpillar Yellow" and the POWER EDGE trade dress, as well as corporate and product identity used herein, are trademarks of Caterpillar and may not be used without permission.

