

## Lubricating Equipment

Lubricating Equipment ..... 12-3



## Lubricating Equipment

### The Graco Warranty

Graco warrants all equipment referenced in this document which is manufactured by Graco and bearing its name to be free from defects in material and workmanship on the date of sale by an authorized Graco distributor to the original purchaser for use. With the exception of any special, extended, or limited warranty published by Graco, Graco will, for a period of twelve months from the date of sale, repair or replace any part of the equipment determined by Graco to be defective. This warranty applies only when the equipment is installed, operated and maintained in accordance with Graco's written recommendations.

This warranty does not cover, and Graco shall not be liable for general wear and tear, or any malfunction, damage or wear caused by faulty installation, misapplication, abrasion, corrosion, inadequate or improper maintenance, negligence, accident, tampering, or substitution of non-Graco component parts. Nor shall Graco be liable for malfunction, damage or wear caused by the incompatibility of Graco equipment with structures, accessories, equipment or materials not supplied by Graco, or the improper design, manufacture, installation, operation or maintenance of structures, accessories, equipment or materials not supplied by Graco.

This warranty is conditioned upon the prepaid return of the equipment claimed to be defective to an authorized Graco distributor for verification of the claimed defect. If the claimed defect is verified, Graco will repair or replace free of charge any defective parts. The equipment will be returned to the original purchaser transportation prepaid. If inspection of the equipment does not disclose any defect in material or workmanship, repairs will be made at a reasonable charge, which charges may include the costs of parts, labor, and transportation.

This warranty is exclusive, and is in lieu of any other warranties, express or implied, including but not limited to warranty of merchantability or warranty of fitness for a particular purpose.

Graco's sole obligation and buyer's sole remedy for any breach of warranty shall be as set forth above. The buyer agrees that no other remedy (including, but not limited to, incidental or consequential damages for lost profits, lost sales, injury to person or property, or any other incidental or consequential loss) shall be available. Any action for breach of warranty must be brought within two (2) years of the date of sale.

GRACO MAKES NO WARRANTY, AND DISCLAIMS ALL IMPLIED WARRANTIES OF MERCHANTABILITY AND FITNESS FOR A PARTICULAR PURPOSE IN CONNECTION WITH ACCESSORIES, EQUIPMENT, MATERIALS OR COMPONENTS SOLD BUT NOT MANUFACTURED BY GRACO. Those items sold, but not manufactured by Graco (such as electric motors, switches, hose, etc.), are subject to the warranty, if any, of their manufacturer. Graco will provide purchaser with reasonable assistance in making any claim for breach of these warranties.

In no event will Graco be liable for indirect, incidental, special or consequential damages resulting from Graco supplying equipment hereunder, or the furnishing, performance, or use of any products or other goods sold hereto, whether due to a breach of contract, breach of warranty, the negligence of Graco, or otherwise.

null

#### Special Warranties for Lubrication Equipment

Graco offers an extended warranty for the following products at no additional cost. All other terms and conditions of the Graco warranty shall apply.

Fire-Ball 300 Pumps: oil and grease 30 years

Fire-Ball 425 Pumps: grease 30 years

Fire-Ball 425 Pumps: oil 10 years

Fire-Ball 225 Pumps: oil 5 years

Falcon Pumps: grease 5 years

Diaphragm Pumps 15 years air valve center section; 5 years pump

250 & 500 Series Hose Reel 3 years

Electronic Fluid Meters 2 years

Matrix 2 years

These extended warranties reflect Graco's high degree of confidence in the quality and consistency of our products.

(Continued)

## The Graco Warranty (Continued)

### For GRACO Canada Customers

The parties acknowledge that they have required that the present document, as well as all documents, notices and legal proceedings entered into, given or instituted pursuant hereto or relating directly or indirectly hereto, be drawn up in English. Les parties reconnaissent avoir convenu que la rédaction du présente document sera en Anglais, ainsi que tous documents, avis et procédures judiciaires exécutés, donnés ou intentés à la suite de ou en rapport, directement ou indirectement, avec les procédures concernées.

## Typical Lubrication System

### Fire-Ball Pump

- Industry leader for lubrication equipment in fast lubes, car dealerships, and medium-sized fleet and equipment service garages
- Quiet
- Provides the power to supply several remote outlets in stationary installations, yet is economical enough for use with portable lubricators
- 7.6 cm (3 in) air motor
- Available in stubby length for wall mounting or various tube lengths to fit containers from 20 to 1100 L (5 to 275 gal) and larger

### President Pump

- Power leader — top choice in large fleet and mass transit service installations
- 10:1 ratio
- Available in stubby length for wall mounting or various tube lengths to fit containers from 60 to 1100 L (16 to 275 gal) and larger
- With a big 10.8 cm (4 1/4 in) air motor, it can supply many outlets for simultaneous use
- Rugged, industrial design
- Valve-in-piston design — only four moving parts
- Balanced differential design
- Hard-coat aluminum construction
- Nonmetallic poppet air valves
- Open-exhaust porting
- Demand-only operation
- Simple in-line design
- Double acting
- Priming piston (grease only)
- Variable volume
- Adjustable throat packing
- Simple design for continuous use
- Provides uniform power on up and down strokes
- Corrosion-resistant — rust-free for longer working life
- Positive sealing even with contaminated air — provides high air flow
- Continuous operation without icing
- No operational costs while pump holds stalled pressure
- Rigid alignment for withstanding abuse
- Positive pump feed even with heavy greases
- Pump adjusts speed to match system demands
- Proven reliability for long life under demanding operating conditions and infrequent maintenance intervals

(Continued)

Typical Lubrication System (Continued)

Item	Description
1	Oil Supply Pumps, also ATF, Gear Lube, and Hydraulic Oil
2a	Oil Valves and Meters
2b	Oil Dispense Bar
3a	Oil Reels
3b	Grease Reels
3c	Air and Water Reels
4a	Grease Pumps
4b	Grease Valve and Swivel
5	Anti-Freeze Supply
6	Air Controls
6a	Regulators
6b	Filters
6c	Lubricators
7	Used Oil Equipment
7a	Drain Funnels
7b	Evac Systems
8	Fluid Inventory Control System
9	Diaphragm Pumps
10	Portable Lube Units

Lubricating Equipment

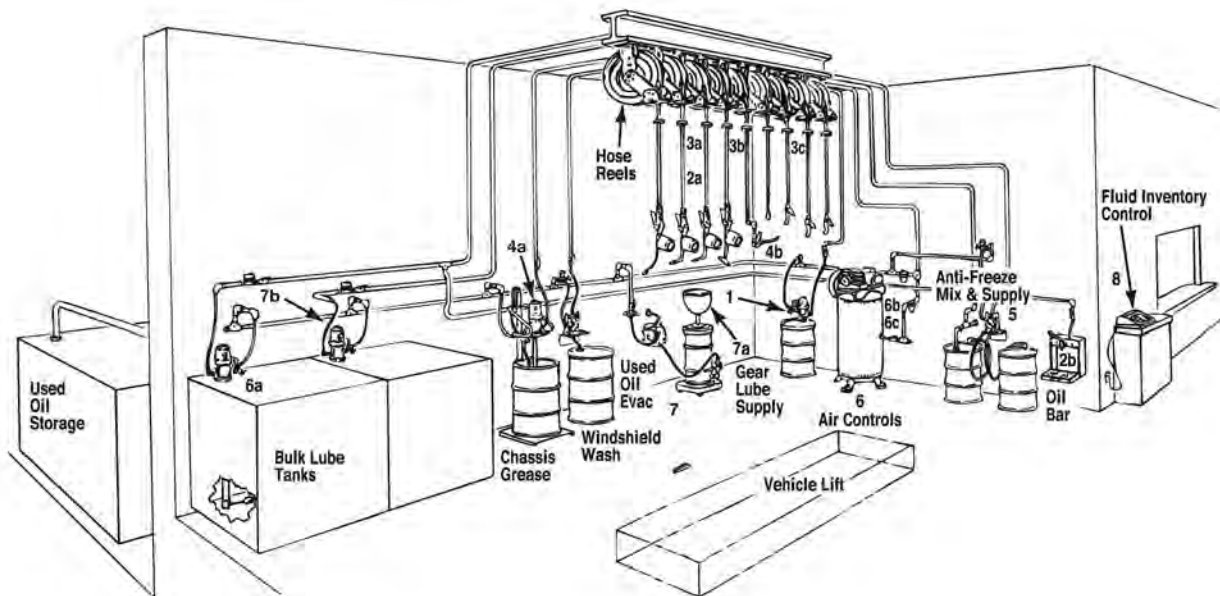

## Pump Performance Specifications

Pump Performance Specifications			
	Fast Ball 1:1	Fire Ball 5:1	President 10:1
Air motor size	3.6 cm (1.48 in)	7.6 cm (3 in)	10.8 cm (4.25 in)
Continuous duty flow rate	18.92 lpm (5 gpm)	9.56 lpm (2.5 gpm)	25 lpm (3 gpm)
Free flow	37.85 lpm (10 gpm)	22.71 lpm (6 gpm)	28.39 lpm (7.5 gpm)
Maximum fluid pressure	12 bar (180 psi)	62 bar (900 psi)	124 bar (1800 psi)
Maximum air inlet pressure	12 bar (180 psi)	12 bar (180 psi)	7 bar (100 psi)
Air inlet size	1/4 in NPT(f)	3/8 in NPT(f)	1/2 in NPT(f)
Fluid outlet size	3/4 in NPT(f)	1/2 in NPT(f)	3/4 in NPT(f)
Fluid inlet size	1 1/2 in NPT(f)	1 1/2 in NPT(f)	1 1/2 in NPT
Pump type	Double Ball	Double Ball	Double Ball
Stroke length	101.6 mm (4 in)	76.2 mm (3 in)	101.6 mm (4 in)
Air consumption	.042 m <sup>3</sup> /min. (1.5 cfm/gal)	1.35 m <sup>3</sup> /min. (7.5 cfm/gal)	6 m <sup>3</sup> /min. (13 cfm/gal pumped)
Instruction manual	307-906	306-518	306-726
Air Motor Repair Kit	9U-6777	9U-6776	—

Part Number	Description
9U-6777	Air Motor Repair Kit
9U-6776	Air Motor Repair Kit

## Lubrication Fast-Ball® Drum Pumps

Warranty: Manufacturer's (See The Graco Warranty)



- 1:1 ratio
- 2.8 to 12.6 bar (40 to 180 psi) air pressure range
- 1/4 inch(f) air inlet
- 3/4 inch(f) fluid outlet
- 15 lpm (5 gpm) maximum delivery

Part No.	Description	Detail
4C-7359	Pump	--
4C-7379	Drum Length Fast-Ball Pump, 208 L (55 gal) Comes complete with bung adapter for drum mounting	208 L (55 gal), Comes complete with bung adapter for drum mounting
4C-7380	Drum Length Fast-Ball Pump, 1041 L (275 gal) Comes complete with bung adapter for drum mounting	1041 L (275 gal), Comes complete with bung adapter for drum mounting
4C-8969	Un-metered Power-Fil Consists of Fast-Ball pump (bung mounted) for 208 L (55 gal) drum and un-metered kit <sup>1</sup>	Consists of Fast-Ball pump (bung mounted) for 208 L (55 gal) drum and un-metered kit

Part No.	Description	Detail
4C-7383	Metered Power-Fil Consists of Fast-Ball pump (bung mounted) for 208 L (55 gal) drum and metered dispense kit <sup>1</sup>	Consists of Fast-Ball pump (bung mounted) for 208 L (55 gal) drum and metered dispense kit

(Continued)

**Lubrication Fast-Ball® Drum Pumps (Continued)**

Warranty: Manufacturer's (See The Graco Warranty)

Part No.	Description	Detail
<b>Fast-Ball Pump Accessories</b>		
4C-8964	Bung Adapter	Allows direct pump mounting into 50.8 mm (2 in) drum bung
4C-7348	Suction Tube	Tubes can be used with stubby Fast-Ball to provide pump length to fit specific drum sizes
4C-7190	Low Level Cut Off	Prevents air from entering metered dispense valves by closing pump intake when oil supply is exhausted; has 1 1/2 in NPT(f) connection.

Part No.	Description	Detail
<b>Fast-Ball Pump Accessories (Continued)</b>		
4C-7261	Suction Hose Kit	Consists of tube, hose and fittings; use with wall bracket; for use with 208 L (55 gal) drum
4C-7196	Wall Bracket	For wall mounting of stubby Fast-Ball pump
4C-8962	Hose and Fitting Kit, 457.2 mm (18 in)	Comes with 6.4 mm (1/4 in) air hose, 19 mm (3/4 in) fluid
4C-8851	Filter	Prevents pipe scale, rust, etc. from damaging pump. 1/4 in NPT(f)
4C-8852	Air Regulator	Controls air pressure to pump. 0-200 psi Adjustable range. 1/4 in NPT(f)
4C-8853	Lubricator	Adds controlled amount of lubricant to air supply; prolongs pump life. 1/4 in NPT(f)

Lubricating Equipment

<sup>1</sup> Power-Fil dispensers include a 0 - 414 kPa (0 -60 psi) regulator to minimize splashing during dispensing. Power-Fil dispensers fit any work-bench tank having a 889 mm (35 in) height

**4C-7261 Suction Hose Kit**

Warranty: Manufacturer's (See The Graco Warranty)

- Consists of drum tube and hose to allow the use of Fire-Ball 5:1 or President 10:1 "Universal" pumps with barrels
- Kit includes 4C-8905 suction tube
- Use with 4C-7190 low-level cutoff when metering fluids
- Includes instruction form



Part Number	Description	Used with
4C-7261	Suction Hose Kit	4C-7190
4C-8905	Suction Tube	--

**Suction Tube Extension Tubes**

Warranty: Manufacturer's (See The Graco Warranty)

- Used with universal Fire-Ball or President pumps to allow cover or bung mounting

Suction Tube Extension Tubes		
Part Number A	Dim. A	
—	80.79 cm (31.81 in)	
Pump	208 L (55 gal)	1,041 L (275 gal)
Fire-Ball 5:1 Cover Mtd.	4C-7347	n/a
Fire-Ball 5:1 Bung Mtd. <sup>1</sup>	4C-7348	—
President 10:1 Cover Mtd.	4C-7347	n/a
President 10:1 Bung Mtd. <sup>1</sup>	4C-7348	—

<sup>1</sup> Also order bung adapter

(Continued)

## Suction Tube Extension Tubes (Continued)

Warranty: Manufacturer's (See The Graco Warranty)

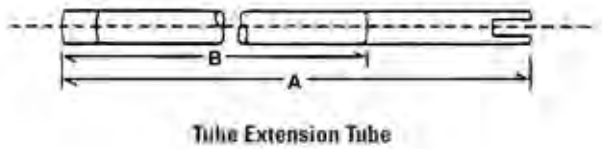

Part Number	Description	Diameter
<b>Part Number A</b>		
4C-7345	Suction Tube Extension Tube	41.42 cm (16.31 in)
4C-7347	Suction Tube Extension Tube	60.47 cm (23.81 in)
4C-7348	Suction Tube Extension Tube	71.27 cm (28.06 in)
4C-9000	Suction Tube Extension Tube	106.19 cm (41.81 in)
<b>Part Number B</b>		
4C-9001	Suction Tube Extension Tube	116.84 cm (46 in)

### 4C-8964 Bung Adapter



- Allows direct mounting of Fire-Ball 5:1 and President 10:1 pumps into standard 50.8 mm (2 in) drum bung

Part Number	Description
4C-8964	Bung Adapter



**4C-7190 Low-Level Cutoff**

Part Number	Description
4C-7190	Low Level Cut Off

- Use with pumps supplying metered outlets
- Prevents air from entering pump by closing intake when supply is exhausted
- Connection thread: 1 1/2 inch NPT(f)
- Can be used with suction hose kit or standard suction tube without changing tube length
- Replaces stand-off of suction tube



Lubricating Equipment

**Oil Dispense Accessories**

Warranty: Manufacturer's (See The Graco Warranty)

**4C-7044 Oil Line Shutoff Valve, 1/2 inch NPT(f)**

**4C-7045 Oil Line Shutoff Valve, 3/8 inch NPT(f)**

Part No.	Description	Detail
4C-7044	Fluid Ball Valve	1/2 in NPT(f)
4C-7045	Fluid Shut-Off Valve	3/8 in NPT(f)

- Shutoff valves for isolation of oil dispense lines
- Use 4C-7044 for branch lines
- Use 4C-7045 for main header lines
- Both valves rated for 138 bar (2000 psi) working pressure



**Dispense Pump Hose and Fitting Kits**

Warranty: Manufacturer's (See The Graco Warranty)

**4C-7362 1.83 m (72 in) Hose and Fitting Kit for Fire-Ball 5:1**

Warranty: Manufacturer's (See The Graco Warranty)

- Use 18 inch kit for connecting wall mounted pumps to piping
- Use 72 inch kit with drum mounted pumps
- Use 4C-7046 3/8 inch air regulator as required (not included, sold separately)

Includes:	
Description	Size
Air Hose	3/8 in
Instruction Form 307-883	

Part Number	Description	Size
4C-7362	Air/Fluid Hose Kit, 1.8 m (6 ft)	1.8 m (6 ft)
Consist		
4C-7101	Union	1/2 in
4C-7102	Union	3/8 in
4C-7334	Hose 3000	1/2 in

## 4C-7364 1.83 m (72 in) Hose and Fitting Kit for President 10:1



- Use 45.72 cm (18 in) kit for connecting wall mounted pumps to piping
- Use 1.83 m (72 in) kit with drum mounted pumps
- Use 4C-7046 3/8 inch air regulator as required (not included, sold separately)

Part No.	Description	Length	Fittings
4C-7364	Hose and Fitting Kit	--	--
<b>12.7 mm (1/2 in) ID - 207 bar (3000 PSI)</b>			
4C-7334	Hose 3000	1.83 m (72 in)	1/2 in M x 1/2 in M
4C-7335	Hose 3000	4.88 m (16 ft)	1/2 in M x 1/2 in M
4C-7336	Hose 3000	6.10 m (20 ft)	1/2 in M x 1/2 in M
4C-7337	Hose 3000	45.72 cm (18 in)	1/2 in M x 1/2 in M
4C-7341	Hose 3000	7.62 m (25 ft)	1/2 in M x 1/2 in M
4C-7354	Hose 3000	15.24 m (50 ft)	1/2 in M x 1/2 in M

Part No.	Description	Length	Fittings
<b>19.05 mm (3/4 in) ID - 157.5 bar (2250 PSI)</b>			
4C-7047	Hose 2250	1.83 m (72 in)	3/4 in M x 3/4 in M
4C-7048	Hose 2250	45.72 cm (18 in)	3/4 in M x 3/4 in M
4C-9019	Suction Hose	304.8 cm (12 in)	3/4 in M x 3/4 in M
<b>Consist<sup>1</sup></b>			
4C-7047	Hose 2250	1.83 m (72 in)	3/4 in M x 3/4 in M
4C-7101	Union	--	1/2 in
4C-7221	Hose 180	--	1/2 in
<b>Service/Repair Parts for Discontinued 4C-7366, 45.72 cm (18 in) Hose and Fitting Kit for President 10:1<sup>2</sup></b>			
4C-7048	Hose 2250	45.72 cm (18 in)	3/4 in M x 3/4 in M
4C-7101	Union	--	1/2 in

<sup>1</sup> Includes Instruction Form: 307-883

<sup>2</sup> Also: Instruction Form: 306-520

## Air Operated Oil Pumps — Universal Length

Warranty: Manufacturer's (See The Graco Warranty)



- Universal Length Dispense Pumps consist of a short "Stubby" length pump with a threaded inlet, allowing the use of a variety of inlet tubes or hoses
- Can be wall mounted for use with a suction hose kit or add a suction tube to create a drum pump of the length of your choice
- For cover mounting, add only the appropriate suction tube
- For bung mounting, add the appropriate suction tube and a bung adapter

### 4C-7195 Universal Fire-Ball 5:1

- The pump of choice for most installations
- Pump free flow is approximately 28.5 lpm (7 1/2 gpm) and will deliver 7.6 to 11.4 lpm (2 to 3 gpm) under typical operating conditions
- Includes instruction form 306-518
- Does not include hoses or accessories

### 4C-7228 Universal Air Pump 10:1

- Use this pump for large installations having long dispense lines where low air pressures would otherwise limit pump performance, or for cold weather operation
- Similar to Fire-Ball 5:1 but uses the President air motor and has a higher ratio

(Continued)

### Air Operated Oil Pumps — Universal Length (Continued)

Warranty: Manufacturer's (See The Graco Warranty)

- Pump free flow is approximately 28.5 lpm (7 1/2 gpm) and will deliver 11.4 to 15.2 lpm (3 to 4 gpm) under typical operating conditions
- Includes instruction form 306-726
- Does not include hoses or accessories

Part No.	Maximum Air Inlet Pressure	Air Inlet	Fluid Outlet	Fluid Inlet
4C-7195	12.6 bar (180 psi)	3/8 in NPT(f)	1/2 in NPT(f)	1 1/2 in NPT(f)
4C-7228	12.6 bar (180 psi)	1/2 in NPT(f)	1 in NPT(f)	1 1/2 in NPT(f)

### Air Operated Oil Pumps — Cover-Mounted

Warranty: Manufacturer's (See the Graco Warranty)

Part No.	Description
4C-7406	Air Operated Oil Pump

#### 4C-7406 President 10:1

- Pump, cover, inlet and outlet hoses and all hardware needed for direct mounting on 205 L (55 gal) open-head product drum
- Order low level cut-off separately for metered dispense systems
- Use 4C-7033 Air Regulator, 12.7 mm (1/2 in) as required (not included, sold separately)

205 Liter (55 Gallon) Drum-Length Pumps



### Air Operated Oil Pumps — Bung-Mounted

Warranty: Manufacturer's (See The Graco Warranty)

- Pumps are both designed for direct bung mounting in 51 mm (2 in) bung in 205 L (55 gal) closed-head drums
- Order low level cut-off separately for metered dispense systems (sold separately)

Part Number	Description
<b>Fire-Ball 5:1</b>	
4C-7195	Fire-Ball 5:1 pump (Stubby)
4C-7348	Suction Tube
4C-7362	Air/Fluid Hose Kit, 1.8 m (6 ft)
4C-8964	Bung Adapter
<b>President 10:1</b>	
4C-7228	Pump
4C-7348	Suction Tube
4C-7364	Hose and Fitting Kit
4C-8964	Bung Adapter

205 Liter (55 Gallon) Drum Length Pump



## Bulk Tank Assembly — Air Operated

### Tank Mounted Pump Assembly

Warranty: Manufacturer's (See The Graco Warranty)

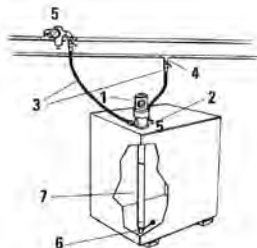

Tank Mounted Pump Assembly

- Order tanks separately

Item	Description
7	Pump Tubes

Item	Part Number	Description
<b>Tank Mounted Pump Assembly</b>		
1	4C-7195	Fire-Ball 5:1 pump (Stubby)
2	4C-8964	Bung Adapter
2	4C-7362	Air/Fluid Hose Kit, 1.8 m (6 ft)
3	4C-7044	Fluid Ball Valve
4	4C-7046	Regulator
6	4C-7190	Low Level Cut Off

### Stubby Mounted Pump Assembly

Warranty: Manufacturer's (See The Graco Warranty)

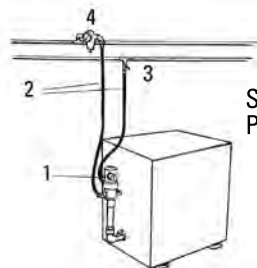

Stubby Mounted Pumps Assembly

Item	Part Number	Description
<b>Stubby Mounted Pump Assembly - use on 454 to 7,570 L (120 to 2,000 gal) tanks</b>		
1	4C-7195	Fire-Ball 5:1 pump (Stubby)
2	4C-7362	Air/Fluid Hose Kit, 1.8 m (6 ft)
3	4C-7044	Fluid Ball Valve
4	4C-7046	Regulator

## Above Ground Storage Tanks

Availability: NACD

Warranty: Manufacturer's (See The Graco Warranty)



Multi-purpose tanks for storage of lubricants and used oil. Four-inch welded bottom skids keep the tank bottom off the floor.

- Tanks are painted white
- Locking fill cap
- In-tank level gauge provides a means of inventory control
- Single and double wall available
- Portable
- Underwriters Laboratory approved
- 3-year manufacturer's warranty
- Call for quote

**Typical U/L Listed Single Wall Bulk Tank**

Capacity	Length	Width	Height <sup>1</sup>
456 L (120 gal)	66.04 cm (2 ft 2 in)	76.2 cm (30 in)	91.44 cm (3 ft)
1064 L (280 gal)	152.4 cm (5 ft)	76.2 cm (30 in)	91.44 cm (3 ft)
1900 L (500 gal)	152.4 cm (5 ft)	81.28 cm (32 in)	152.4 cm (5 ft)
2470 L (650 gal)	198.12 cm (6 ft 6 in)	81.28 cm (32 in)	152.4 cm (5 ft)
3800 L (1000 gal)	304.8 cm (10 ft)	81.28 cm (32 in)	152.4 cm (5 ft)
5700 L (1500 gal)	457.2 cm (15 ft)	81.28 cm (32 in)	152.4 cm (5 ft)
7600 L (2000 gal)	548.64 cm (18 ft)	76.2 cm (30 in)	182.88 cm (6 ft)

<sup>1</sup> Add 10.16 cm (4 in) for skids

**Typical U/L Listed Double Wall Bulk Tank**

Capacity	Length	Width	Height <sup>1</sup>
456 L (120 gal)	66.04 cm (2 ft 2 in)	92.71 cm (36 1/2 in)	101.6 cm (3 ft 4 in)
1064 L (280 gal)	160.02 cm (5 ft 3 in)	92.71 cm (36 1/2 in)	101.6 cm (3 ft 4 in)
1900 L (500 gal)	160.02 cm (5 ft 3 in)	97.79 cm (38 1/2 in)	162.56 cm (5 ft 4 in)
2470 L (650 gal)	222.25 cm (7 ft 3 1/2 in)	91.44 cm (36 in)	162.56 cm (5 ft 4 in)
3800 L (1000 gal)	328.93 cm (10 ft 9 1/2 in)	91.44 cm (36 in)	162.56 cm (5 ft 4 in)
5700 L (1500 gal)	481.33 cm (15 ft 9 1/2 in)	91.44 cm (36 in)	162.56 cm (5 ft 4 in)
7600 L (2000 gal)	572.77 cm (18 ft 9 1/2 in)	86.36 cm (34 in)	193.04 cm (6 ft 4 in)

<sup>1</sup> Add 38.1 mm (1 1/2 in) for skids

**Remote Drum Pump Assemblies — Air Operated**

Warranty: Manufacturer's (See The Graco Warranty)

- Drum not included

**Bung Mount, 60 liter (16 gallon)**

Item	Part Number	Description	Detail
<b>Bung Mount, 60 liter (16 gallon)</b>			
1	4C-7044	Fluid Ball Valve	--
2	4C-7046	Regulator	--
3	4C-8858	Coupler	Quick Disconnect Coupler 3/8 in(f)
4	4C-7159	Fitting	3/8 in(m)



**Drum Cover Mount, 60 liter (16 gallon)**

Item	Part Number	Description	Detail
<b>Drum Cover Mount, 60 liter (16 gallon)</b>			
1	4C-7044	Fluid Ball Valve	--
2	4C-7046	Regulator	--
3	4C-8858	Coupler	Quick Disconnect Coupler 3/8 in(f)
4	4C-7159	Fitting	3/8 in(m)



## Wall Mount, 60 liter (16 gallon)

Lubricating Equipment

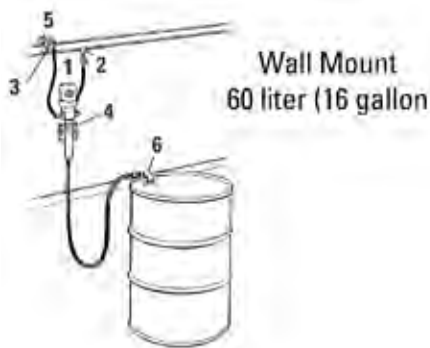

Item	Part Number	Description	Detail
<b>Wall Mount, 60 liter (16 gallon)</b>			
1	4C-7195	Fire-Ball 5:1 pump (Stubby)	Wall Mounted, 457.2 mm (18 in) Air and Fluid Hoses
2	4C-7044	Fluid Ball Valve	--
3	4C-7046	Regulator	--
4	4C-8858	Coupler	Quick Disconnect Coupler 3/8 in(f)
5	4C-7159	Fitting	3/8 in(m)
6	4C-7261	Suction Hose Kit	--

## 4C-9710 Hand-Lever Diaphragm Pump

Warranty: Manufacturer's (See The Graco Warranty)



- 4C-9710 replaces discontinued 4C-9769 Quartstroke Pump
- Double-action, high volume diaphragm pump — transfers approximately 3.7 L (1 gal) per 9 strokes
- Telescopic suction tube mounts in 2 inch NPT bung opening of 60 or 205 L (16 or 55 gal) drum
- Package includes 1.8 m (6 ft) hose and fitting kit and bung adapter

Part No.	Description
4C-9710	Hand-Lever Diaphragm Pump

## Pump Mounting Accessories

Warranty: Manufacturer's (See The Graco Warranty)

### 4C-7166 Drum Cover, 181.4 kg/208.2 L (400 lb/55 gal)



- Use with 181.4 kg/208.2 L (400 lb/55 gal) open head drums
- Mounts any Fire-Ball or President lubrication pump
- Use with 4C-7146 Adapter for cover mounting bung pumps

Part Number	Description
4C-7166	Drum Cover

### 4C-7209 Drum Cover, 54.4 kg/60.6 L (120 lb/16 gal) or 31.8 kg/37.9 L (70 lb/10 gal)



- Use with 54.4 kg/60.6 L (120 lb/16 gal) or 31.8 kg/37.9 L (70 lb/10 gal) open head drums
- Mounts any Fire-Ball or President lubrication pump
- Use with 4C-7146 Adapter for cover mounting bung pumps

Part Number	Description
4C-7209	Drum Cover

**4C-7360 Pail Cover, 15.9 kg/18.9 L (35 lb/5 gal)**

Part Number	Description
4C-7360	Pail Cover

- Use with 15.9 kg/18.9 L (35 lb/5 gal) pails
- Mounts Fire-Ball 50:1 pump using friction-type clutch lock
- Allows use of 31.8 kg (70 lb) length pump with 18.9 kg (35 lb) pail



**4C-7234 Pail Cover, 15.9 kg/18.9 L (35 lb/5 gal)**

Part Number	Description
4C-7234	Pail Cover

- Use with 15.9 kg/18.9 L (35 lb/5 gal) pails
- Mounts Fire-Ball 50:1 pump using friction-type clutch lock
- Allows use of 31.8 kg (70 lb) length pump with 18.9 kg (35 lb) pail

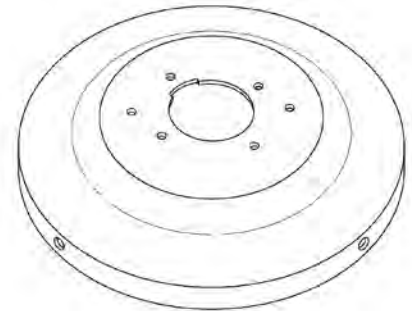

**4C-7146 Cover to Bung Adapter Plate**

Part Number	Description
4C-7146	Adapter Plate

- Mounts to standard 208.2 L/181.4 kg (55 gal 400 lb) or 60.6 L/54.4 kg (16 gal/120 lb) drum cover and converts mounting to standard 2 inch NPT bung opening
- Allows use of bung-mounted pumps with drum covers



**4C-7196 Wall Bracket — “Universal”**

Part Number	Description
4C-7196	Wall Bracket

- Use with Fast-Ball 1:1, Fire-Ball 5:1, President 10:1
- Clamps on “Universal” pump tube



## Bulk Lube Pump Accessories

Warranty: Manufacturer's (See The Graco Warranty)

- Drum not included

### 4C-7261 Suction Hose Kit



Part Number	Description
4C-7261	Suction Hose Kit

### 4C-8858 Air Quick Disconnect Coupler, 3/8inch (f)



Air Quick Disconnect Coupler

Part No.	Description	Size
4C-8858	Coupler	3/8 in NPT(f)

### 4C-7159 Air Quick Disconnect Nipple, 3/8 inch (m)



Air Quick Disconnect Nipple

Part No.	Description	Size
4C-7159	Fitting	3/8 in (m)

## Portable Bases

Warranty: Manufacturer's (See The Graco Warranty)

### 4C-7216 Band Dolly, 18.92 L (5 gal) Pail

### 4C-7199 Band Dolly 10/16 gallon Drums

- Pail nests inside band ring
- Ring clamps hold pail/drum secure
- Casters provide portability



Part No.	Description	Detail
4C-7216	Band Dolly	for 18.92 L (5 gal) Pail
4C-7199	Band Dolly	for 10/16 gallon Drums



**4C-7187 Caster Base — 10/16 gallon Drums**

Part No.	Description	Detail
4C-7187	Caster Base	for 10/16 gallon Drums

- Drum fits into recess on formed base
- Rim clamps hold drum securely onto base
- Casters provide portability



**4C-7189 Two Wheel Cart — 10/16 gallon Drums**

Part No.	Description	Detail
4C-7189	Wheel Cart	for 10/16 gallon Drums

- Drum fits into recess on formed base
- Rim clamps hold drum securely onto base
- Wheels provide portability



Lubricating Equipment

**Un-metered Dispensing Valves**

Warranty: Manufacturer's (See The Graco Warranty)

- In-line style gear lube and A.T.F. mechanical valves for dispensing oil
- Each valve includes non-drip nozzle

Part Number	Description	Flow Rate	Inlet
4C-7241	Un-metered ATF Dispensing Valve	0 - 11.3 lpm (0 - 3 gpm)	1/2 in NPT
4C-7242	Un-metered Oil Dispensing Valve	0 - 11.3 lpm (0 - 3 gpm)	1/2 in NPT
4C-7182	Un-metered Gear Lube Dispensing Valve	0 - 11.3 lpm (0 - 3 gpm)	1/2 in NPT



**157-5548 Electronic Meter Valve**

**157-5550 Electronic Preset Meter Automatic Shut-off Valve**

Warranty: Manufacturer's (See The Graco Warranty)

European Union compliant, CE marked

- Meter valve dispenses bulk service fluids such as motor oil, gear oil, automatic transmission fluid, hydraulic oil, or antifreeze
- 157-5550 has preset capability to allow "hands-free" operation with automatic shut-off
- Dispenses in pints, quarts, gallons, or liters — change units of measure in seconds
- Other features include protective swivel cover, impact guard, non-drip nozzle, and battery operated internal memory
- Resettable memory totals will track daily or weekly volumes of fluids
- Non-resettable memory for lifetime accumulated total
- Comes with both flexible hose and rigid tube extensions



(Continued)

## 157-5548 Electronic Meter Valve (Continued)

## 157-5550 Electronic Preset Meter Automatic Shut-off Valve

Warranty: Manufacturer's (See The Graco Warranty)

- FM and CSA approved

Part Number	Maximum Flow Rate	Operating Pressure	Weight	Inlet Thread	Outlet Thread	Battery
157-5550	18.5 lpm (5 gpm)	6.9 - 69 bar (10 - 1000 psi)	1.14 kg (2.5 lb)	1/2 NPT	3/8 NPT	1U-9534, 9V alkaline
157-5548	18.5 lpm (5 gpm)	6.9 - 69 bar (10 - 1000 psi)	1.14 kg (2.5 lb)	1/2 NPT	3/8 NPT	1U-9534, 9V alkaline

## 360-9249 Electronic Grease Meter

Model Usage: 795F AC Off-Highway Truck

Warranty: Six Months



Specifications	
Inlet/Outlet	1/8" NPFT
Metric Current Delivery and Total delivery units	3% accuracy
Current Delivery Rate	0 - 9999 g (0 - 1.3 oz)
Total Delivery Rate	0 to 999999 kg (36.13 lb/in <sup>3</sup> )
Batteries	Two 1.5V N size
Flow Rate	.1 to 2.5 kg/min flow rate
Max Operating Pressure	10,000 psi (700 bar)
Operating Temperature Range	-10° C (14° F) to 60° C (140° F)
Dimensions (Approximate)	70mm x 80mm x 46mm (.23ft x .23ft x .15ft)

Part Number	Description
360-9249	Electronic Grease Meter

## Metered Dispensing Valve, English or Metric

Warranty: Manufacturer's (See The Graco Warranty)

European Union compliant, CE marked (157-5556)

- Great for applications where up to 45 lpm (12 gpm) is required
- Locking trigger allows hands-free dispensing
- Easy trigger pull for operator comfort
- Electronic meter designed to with stand rugged environment
- Meets CSA and FM approvals



Part Number	Description	Maximum Recommended Flow Rate	Maximum Operating Pressure	Operating Temperature Range	Inlet	Outlet
157-5553	Metered Dispensing Valve (English)	45 lpm (12 gpm)	10.5 MPa, 105 bar (1500 psi)	-20° to 55° C (-4° to 130° F)	3/4 in NPT	1/2 in NPT
157-5556	Metered Dispensing Valve (Metric)	45 lpm (12 gpm)	10.5 MPa, 105 bar (1500 psi)	-20° to 55° C (-4° to 130° F)	3/4 in NPT	1/2 in NPT

### 157-5567 Dispensing Valve

Warranty: Manufacturer's (See The Graco Warranty)

- Great for applications where up to 45 lpm (12 gpm) is required
- Locking trigger allows hands-free dispensing
- Easy trigger pull for operator comfort
- Meets CSA and FM approvals



Part Number	Description	Maximum Recommended Flow Rate	Maximum Operating Pressure	Weight	Operating Temperature Range	Inlet	Outlet
157-5567	Dispensing Valve	45 lpm (12 gpm)	10.5 MPa, 105 bar (1500 psi)	0.18 kg (0.4 lb)	-40° to 82° C (-40° to 180° F)	3/4 in NPT	1/2 in NPT

### 4C-7330 Meter Kit

Warranty: Manufacturer's (See The Graco Warranty)

Part Number	Description
4C-7330	Meter Kit

- Fluid meter can be added to any individual tap by the installation of a meter kit
- Kit includes all necessary mounting hardware (mechanical meter)



### 294-2317 Filter Assembly

Warranty: Six Months

- Used to filter oil in hose reel, drop-lines applications for all oil viscosities
- 3/4 inch NPT female ports makes filter easy to install before a dispensing valve
- 10 micron element filters oils up to 15W40 while 25 micron element filters up to 60 weight oils
- Use 5K-0216 O-ring for filter housing seal replacement, if necessary
- Housing is made from aluminum
- Filter assembly is sold without filter element

Flow Rate	114 lpm (30 gpm)
Weight	0.998 kg (2.2 lb)
Working Pressure	10,342 kPa (1,500 psi)



(Continued)

## 294-2317 Filter Assembly (Continued)

Warranty: Six Months

Part Number	Description	Material	Length	Diameter	Weight	Collapse Pressure
294-2317	Filter Assembly	--	--	--	--	--
294-2320	Filter Element 10 micron	Synthetic Z-glass filter media with zinc plated-cage and epoxy bedding	113.8 mm (4.48 in)	44.7 mm (1.76 in)	1 kg (2.20 lb)	1034 kPa (150 psi)
294-3487	Filter Element (25 micron)	Synthetic Z-glass filter media with zinc plated-cage and epoxy bedding	113.8 mm (4.48 in)	44.7 mm (1.76 in)	1 kg (2.20 lb)	1034 kPa (150 psi)

## Inventory Control Systems

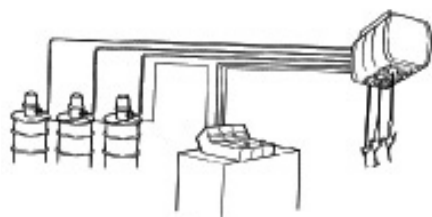

Fluid Commander

### What it Does...

The Fluid Commander provides the key to making bulk dispensing of lubricants practical. From a centrally-mounted console, a manager can determine when and in what quantity lubricants are dispensed to a specific service location.

- **Reduce Product Costs** — By purchasing in bulk, product costs are reduced; Fluid Commander allows dispensing from a hose reel or oil bar only in the quantity authorized
- **Prevent Theft** — A key lock on the control prevents unauthorized dispensing of fluids, even after hours. Eliminates inventory shrinkage
- **Eliminate Forgotten Charges** — By controlling dispense from a central point, entering charges on a job ticket or fleet record no longer depends on the memory or record-keeping ability of the service technician
- **Inventory Management** — A digital display on each product module shows the total amount dispensed (allows usage totals to be recorded and bulk tanks to be refilled according to actual demands, eliminating an out-of-stock situation)
- **Labor Savings** — Dispensing lubricants from bulk eliminates the costly and labor-intensive use of individual cans and containers, allowing the service technician to be more productive

### How it Works...

1. The service technician requests a desired quantity of product and gives his service bay number.
2. The manager then enters the type of product, the quantity, and the service location, and then activates a dispense button.
3. A ready light, located on the technician's hose reel or dispense bar, indicates when dispensing can begin.
4. As product is dispensed, the Fluid Commander keeps count of the amount dispensed and shuts off when the preset amount is reached. The system is then closed to further dispensing until again authorized.

Contact the Dealer Service Tools Division for design of these systems.

### Electronic Fluid Commander — Fluid/Dispense Station Options

Warranty: Manufacturer's (See The Graco Warranty)

#### Typical Fluid Dispensing System Consist

- Air shutoff valve, bleed type
- Air filter
- Air solenoid valve
- Air regulator
- Pump (as required — see Air Operated Oil Pumps)
- Fluid strainer
- Fluid shutoff valve
- Fluid solenoid valve
- Hose reel
- Reel kit includes a low voltage solenoid with ready light mounted on the hose reel (light remains illuminated until technician dispenses authorized fluid amount)
- Ready light
- Dispense valve (as required)

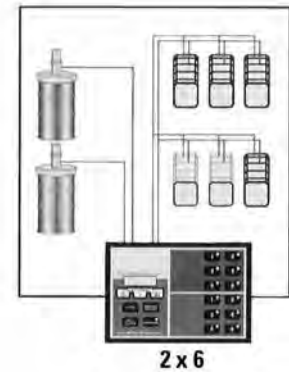

Pulse meter at each pump assures precise fluid flow measurement. Solid-state design for maintenance-free performance. Rated at 10,342 kPa (1,500 psi)

Thermal relief kit protects the system from the potential damage of thermal pressure expansion (excess fluid pressure is harmlessly directed through the valve back to the supply container)

Maximum number of fluids	2
Maximum dispense stations (bays)	6
Air solenoids required	1 per pump
Fluid solenoids required	1 per fluid dispense station
Electrical requirements	120 V / 60 Hz, single-phase, 0.25 A
Digital readout	Liquid crystal display
Incremental measurements	Pints, quarts or gallons
Dimensions (L x W x H)	234 x 203 x 114 mm (9 1/2 x 8 x 4 1/2 in)
Weight	1.6 kg (3 lb, 7 oz)

Part Number	Description	Size
9U-6013	Fluid Dispensing System	2 x 6

#### Accessories (Sold Separately) - Electronic Fluid Commander

Part Number	Description	Size
<b>Accessories (Sold Separately)</b>		
9U-6020	Preconnected Cable	30 m (100 ft)
9U-6026	Fluid Solenoid	--
9U-6016	Pulse Meter	--
4C-7044	Fluid Ball Valve	12.7 mm (1/2 in)

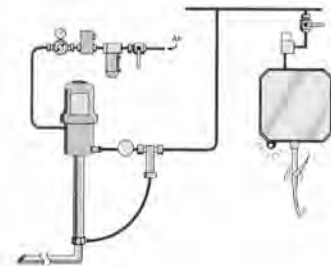

## Air-Operated Grease Pumps — Fire-Ball and President Pumps

### Fire-Ball Pumps

- Heavy-duty quiet Fire-Ball pumps are the industry choice for manufacturing, process and maintenance applications
- The Fire-Ball 50:1 provides the power to supply several remote outlets in stationary installations, yet is economical enough for use with portable lubricators
- The 50:1 pump is available in 3 standard tube lengths to fit 15.8 kg (35 lb), 54.4 kg (120 lb) and 181.4 kg (400 lb) grease containers

### President Pumps

- Heavy-duty, high-capacity President 50:1 pump is the top choice for in-plant, construction, mining and railroad maintenance facilities
- Available with tube lengths to fit 54.4 kg (120 lb) or 181.4 kg (400 lb) drums
- With a big 10.1 cm (4 1/4 in) air motor, the President pump can supply grease to many outlets for simultaneous use
- For use in supplying grease to heavy equipment in high volumes

Pump Performance Specifications		
	Fire-Ball 50:1	President 50:1
Flow capacity (grease at 8 lb/gal)		
Free flow	1.8 kg/min (4 lb/min)	5 kg/min (11 lb/min)
60 cycles/min	0.90 kg/min (2 lb/min)	1.8 kg/min (4 lb/min)
Maximum fluid pressure	550 bar (8100 psi)	510 bar (7500 psi)
Fluid inlet	Priming piston (slot)	3/8 in NPT(f)
Fluid outlet	1/4 in NPT(f)	3/8 in NPT(f)
Pump design	Priming piston (shovel)	Priming piston (shovel)
Air motor diameter	3 in (7.6 cm)	4 1/4 in (10.1 cm)
Air inlet	3/8 in NPT(f)	1/2 in NPT(f)
Maximum inbound air pressure	10.2 bar (150 psi)	23.3 bar (180 psi)
Service kit for pump lower	204-164	206-928
Service kit for air motor	206-728	207-385
Air-operated grease pumps are available in the 76.2 mm (3 in) Fire-Ball and 108 mm (4 1/4 in) President, with a variety of tube lengths to fit anysize container, from small pails to 181.4 kg (400 lb) drums to bulk tanks. These pumps are available as cover mounted, roll-around portable, or with elevators to facilitate drum changing.		

### ⚠ WARNING

Very high pressure. Read instruction manual for safe use of grease pumps.

## Drum-Length Pumps

Warranty: Manufacturer's (See The Graco Warranty)



### Fire-Ball 50:1

- The pump of choice of most installations
- Free flow is approximately 3.8 lpm (1 gpm), and the pump will provide flow for up to 2 dispense valves, operated simultaneously, although the number of dispense drops is unlimited
- Does not include hoses or accessories

### President 50:1 — High-Volume

- The pump of choice for applications where higher flow is necessary
- Free flow is approximately 5.3 lpm (1.4 gpm), and pump will provide flow for up to 4 dispense valves operated simultaneously, although the number of dispense drops is unlimited
- Does not include hoses or accessories

(Continued)

**Drum-Length Pumps (Continued)**

Warranty: Manufacturer's (See The Graco Warranty)

Part Number	Description	Weight	Maximum Air Inlet Pressure	Air Inlet	Fluid Outlet
<b>Fire-Ball 50:1</b>					
4C-7193	Drum-Length Pump, Fire-Ball 50:1	181.4 kg (400 lb)	180 psi	3/8 in NPT(f)	1/4 in NPT(f)
4C-7194	Drum-Length Pump, Fire-Ball 50:1	54.4 kg (120 lb)	180 psi	3/8 in NPT(f)	1/4 in NPT(f)
<b>President 50:1 - High-Volume</b>					
4C-7219	Drum-Length Pump, President 50:1	54.4 kg (120 lb)	180 psi	1/2 in NPT(f)	3/8 in NPT(f)
4C-7220	Drum-Length Pump, President 50:1	181.4 kg (400 lb)	180 psi	1/2 in NPT(f)	3/8 in NPT(f)

Lubricating Equipment

**Air Operated Portable Grease Dispensers**

Warranty: Manufacturer's (See The Graco Warranty)

**E-Line System**

- Caster base of this system provides maximum portability; the pump and cover mount directly on a 54.4 kg (120 lb) product drum
- Exposed drum provides ready product identification
- Includes pump, cover, base, follower plate, holster, 1.8 m (6 ft) dispense kit, instruction form
- Dispenser does not include drum
- Use 4C-7046 3/8 inch Air Regulator as required (not included, sold separately)

**System with Cart**

- Same as 4C-7389 but has a 2-wheel cart
- Includes pump, cover, cart, follower plate, holster, dispense kit, instruction form
- Use 4C-7046 3/8 inch Air Regulator as required (not included, sold separately)

**Pail Dispenser**

- Hand-portable assembly mounts directly on a 15.9 kg (35 lb) pail and is the best choice for maximum portability
- Includes pump, cover, follower plate, 1.8 m (6 ft) dispense kit, instruction form
- Use 4C-7046 3/8 inch Air Regulator as required (not included, sold separately)



4C-7389



4C-7392



4C-7367

(Continued)

## Air Operated Portable Grease Dispensers (Continued)

Warranty: Manufacturer's (See The Graco Warranty)

Part Number	Description	Weight
<b>E-Line System</b>		
4C-7389	Air Operated Portable Grease Dispenser, Fire-Ball 50:1	54.4 kg (120 lb)
<b>System with Cart</b>		
4C-7392	Air Operated Portable Grease Dispenser, Fire-Ball 50:1	54.4 kg (120 lb)
<b>Pail Dispenser</b>		
4C-7367	16 kg (35 lb) Pail Dispenser, Fire-Ball 50:1	16 kg (35 lb)

## 331-3626 Volume Compressor

Model Usage: Small stored engines

Warranty: Six months

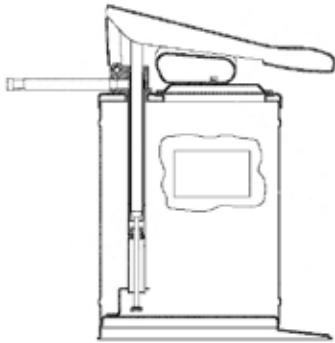

- 331-3626 Volume Compressor is used as a pre-lube pump to pump oil into engines being removed from storage.
- Connector is a 1/8" - 27 NPT Female
- Tool replaces the cancelled 1P-0540

Part Number	Description
331-3626	Volume Compressor

## Hand Operated Portable Grease Dispenser

Warranty: Manufacturer's (See The Graco Warranty)



**Hand operated grease dispensers deliver lubricants from 16 kg (35 lb) pail or from portable bulk containers. They provide portability to the job site even when no source of power is available.**

### Pail Dispenser

- This lever operated pump and cover mount directly on a 35 lb (5 gallon) pail
- The pump delivers 0.01 L (0.25 oz) of grease per stroke at pressures to 207 bar (3000 psi)
- It includes a 1.5 m (5 ft) hose with coupler and 4C-7191 "Hot-Shot" Booster Gun
- The pump can service fittings directly or can be used with a booster gun for more portability and higher pressures

Part No.	Description	Detail	Weight
4C-7414	Pail Dispenser	Buckshot Luber with Booster Gun	16 kg (35 lb)



### “Topper” Inductor Pumps for Non-Pourable Greases and Oils

Warranty: Manufacturer’s (See The Graco Warranty)

**Inductor or “topper” pumps reduce labor costs and downtime, and seal lubricant drums to prevent entry of foreign material.**

- No wasted grease — a rubber wiper on the inductor plate wipes the drum clean as the grease is dispensed (no hand cleaning of the drum)
- Positive pump feed — the inductor plate seals against aeration and uses the weight of the plate and pump to provide positive pump feed (no aeration, and drum is sealed against entry of foreign material)
- Fast barrel changeover — air operated elevator provides fast drum changes resulting in increased production

#### Stationary Topper Pump System

- The baseplate mounted elevator supports Fire-Ball or President grease pumps and inductor plates
- Both systems include air valve and mounting hardware as follows: pump, carriage, elevator, base inductor, 1.8 m (6 ft) hose kit, instruction form
- Use 4C-7046 3/8 inch Air Regulator as required (not included, sold separately)



Part Number	Description	Weight
4C-7419	Stationary Topper Pump System, President 50:1 <sup>1</sup>	181.4 kg (400 lb)

<sup>1</sup>Also offered: Stationary Topper Pump System, Fire-Ball 50:1, same weight

### Cover Mounted Grease Pumps

Warranty: Manufacturer’s (See The Graco Warranty)

#### 181.4 kg (400 lb) System

- Pump, cover, hoses and hardware are ready for direct mounting on 181.4 kg (400 lb) open-head product drum
- Both systems consist of pump, cover, follower plate, 1.8 m (6 ft) hose and fitting kit, instruction kit
- 4C-7391 — use 4C-7046 3/8 inch Air Regulator as required (not included, sold separately)
- 4C-7405 — Use 4C-7033 1/2 inch Air Regulator as required (not included, sold separately)

#### 54.4 kg (120 lb) System

- Pump, cover, hoses and hardware are ready for direct mounting on 181.4 kg (120 lb) open-head product drum
- Includes pump, cover, follower plate, 1.8 m (6 ft) hose and fitting kit, instruction kit
- Use 4C-7046 3/8 inch Air Regulator as required (not included, sold separately)



Part Number	Description	Weight
<b>181.4 kg (400 lb) System</b>		
4C-7391	Cover Mounted Grease Pump, Fire-Ball 50:1	181.4 kg (400 lb)
4C-7405	Cover Mounted Grease Pump, President 50:1	181.4 kg (400 lb)
<b>54.4 kg (120 lb) System</b>		
4C-7390	Cover Mounted Grease Pump, Fire-Ball 50:1	54.4 kg (120 lb)

## Follower Plates

Warranty: Manufacturer's (See The Graco Warranty)

4C-7344



- Follower plates ride on the surface of the grease in a drum to reduce aeration and channeling
- The plates have a center rubber grommet to seal around the pump tube and a formed cone to allow the pump to fully empty the drum without uncovering the pump inlet slots

Part No.	Description	Drum Size	Fits Pumps
4C-7198	Follower Plates	181.4 kg (400 lb)	Fire-Ball 50:1 and 15:1
4C-7218	Follower Plates	181.4 kg (400 lb)	President 50:1
4C-7344	Follower Plates <sup>1</sup>	31.7/54.4 kg (70/120 lb)	Fire-Ball 50:1 and 15:1
4C-7343	Follower Plates <sup>1</sup>	16 kg (35 lb)	Fire-Ball 50:1 and 15:1

<sup>1</sup> Has flexible lip for use with tapered drums/pails.

## Dispense Hose

Warranty: Manufacturer's (See The Graco Warranty)

### Dispense Kit for Fire-Ball 50:1

- For use with portable 50:1 Fire powered lubricators
- Use 4C-7046 3/8 inch Air Regulator, as required (not included, sold separately)

### 72 inch Hose and Fitting Kit for President 50:1

- For use with stationary drum mounted President 50:1 pumps
- Use 4C-7046 3/8 inch Air Regulator, as required (not included, sold separately)

Included:	
Item	Description
307-878	Instruction Form
307-880	Instruction Form

Part Number	Description	Size
<b>Dispense Kit for Fire-Ball 50:1 Consist<sup>1</sup></b>		
4C-7300	Grease Dispense Valve	--
4C-7253	Coupling	1/4 in NPT(f)
4C-7159	Fitting	3/8 in (m)
<b>72 inch Hose and Fitting Kit for President 50:1 Consist<sup>2</sup></b>		
4C-7221	Hose 180	1/2 x 72 in
4C-7101	Union	1/2 in
4C-7102	Union	3/8 in

<sup>1</sup>307-878 Instruction Form included

<sup>2</sup>307-880 Instruction Form included

## Grease Dispense Valves and Accessories

A full selection of lubrication accessories to complete a lubrication system includes nozzles, meters, dispense valves, hydraulic couplers, and similar accessories to make all lubrication work easier and faster.

## Dispense Valves

Warranty: Manufacturer's (See The Graco Warranty)

### 4C-7300 Grease Dispense Valve

Part No.	Description
4C-7300	Grease Dispense Valve
4C-7167	Nozzle

- High-pressure grease valve with knurled grip handle for operator comfort
- 545 bar (8,000 psi) working pressure
- Includes 4C-7167 Nozzle
- Order 4C-7169 Swivel separately



### 4C-7171 Power-Shot Booster Gun

- Boosts pressure of incoming grease to 1,260 bar (18,000 psi)
- For use with any high-pressure lubricator or a booster/dispense valve with hose reels
- Has molded rubber grip handle
- Not for use with flexible hose nozzle
- Order 4C-7170 Hose Swivel separately
- Includes 4C-7167 Nozzle

Part No.	Description	Inlet and Outlet	Maximum Inlet Pressure
4C-7171	Power-Shot Booster Gun	1/8 in NPT(f)	560 bar (8,000 psi)



### 4C-7174 Grease Dispense Line Shut-off Valve

Part Number	Description
4C-7174	Grease Dispense Line Shut-Off Valve

- 1/2 inch NPT(f) ported valve for drop-line isolation
- Needle valve construction rated for 345 bar (5,000 psi)



### 4C-7191 Hot-Shot Booster Gun

Part Number	Description
4C-7191	Hot-Shot Booster Gun

- For portable operation without continuous connection to grease supply
- Has 0.12 L (4 oz) self-contained grease reservoir in handle capable of servicing up to 100 fittings before recharge
- Has grease fitting for recharge from manually-or air-powered luber
- Single-hand operation squeeze handle develops up to 700 bar (10,000 psi)
- Includes standard taper nose hydraulic coupler



## 4C-7169 Swivel, 1/4 inch NPT(m) x 1/4 inch NPT(f)

## 4C-7170 Swivel, 1/8 inch NPT(m) x 1/4 inch NPT(f)



- Three way Z-type hose swivel
- High pressure ball bearing pivots 360° — prevents hose tangling and allows free movement of grease valves
- For use with 4C-7300 Valve

Part No.	Description	Size
4C-7169	NPT Coupling	1/4 inch NPT(m) x 1/4 inch NPT(f)
4C-7170	Swivel	1/8 inch NPT(m) x 1/4 inch NPT(f)
<b>Used With</b>		
4C-7300	Grease Dispense Valve	--

## 317-6529 Grease Dispensing Hand-Pump

### Essential Tool

Model: Articulated Trucks and Wheel Loaders with autolube system

Warranty: Manufacturer's

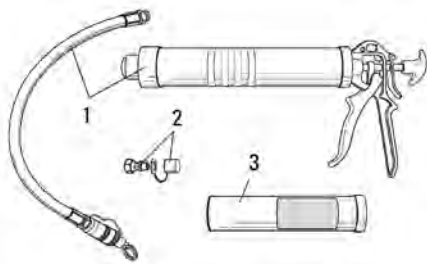

- Used for quick filling of Groeneveld Autolube systems on Cat® machines
- Used with 5P-0960 Grease Cartridge; sold separately
- Used when air-powered greasing system is not available
- Includes one 317-6530 Male Quick Connect Coupler which replaces standard filling coupling on machine
- Additional 317-6530 Male Quick Connect Couplers can be purchased so hand-pump can be used on multiple machines
- Pumps grease at a much higher rate than conventional hand-operated grease pumps
- Refilling an empty reservoir will require nine 5P-0960 Grease Cartridges

### Reference

REN6739; Service Manual; 725, 730, 730 Ejector, 735, 740 and 740 Ejector Articulated Trucks Automatic Lubrication System

Item	Part Number	Description	Detail
1	317-6529	Grease Gun (Auto lube)	--
2	317-6530	Coupler - Grease (Auto lube) <sup>1</sup>	--
3	5P-0960	Grease - A3M <sup>2</sup>	397g (14 oz)

<sup>1</sup> One included in kit. Order additional adapters for multiple machines.

<sup>2</sup> Order separately

## Hose Swivels

Warranty: Six Months

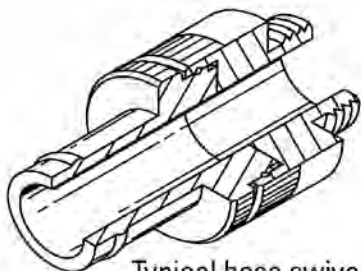

Typical hose swivel

- Used with recommended ecology valve
- Used to quickly and easily drain oil from machine or component without spilling

Part Number	Ecology Valve	Thread Connection	Hose Connection
4C-8563	106-8186	1 5/16 - 12	25.4 mm (1 in)
126-7914	8J-8782	1-11 1/2 NPSM, 2B-thd	25.4 mm (1 in)
176-6545	193-7364	1 15/18 - 12	50.8 mm (2 in)
204-3559	173-0566	3/4 - 14 BSPP	25.4 mm (1 in)

### 290-5686 Spanner Wrench Assembly

Model: Various Cat® Machines

Warranty: Six Months

Part Number	Description
290-5686	Spanner Wrench Assembly

- Allows easy access to remove and install 106-8186 Ecology Drain Valve to replace 077-3241 O-ring Seal
- Used with 1/2 inch square drive wrench



### Grease Nozzles

Warranty: Manufacturer's (See The Graco Warranty)

#### 4C-7167 Standard Grease Nozzle

Part Number	Description
4C-7167	Nozzle

- Provided as standard with most grease dispense valves
- Has 1/8 inch NPT(m)
- 15.24 cm (6 in) extension tube to reach out-of-the-way fittings and taper nose coupler



#### 4C-7197 17.78 cm (7 in) Swivel Grease Nozzle

#### 4C-7212 35.56 cm (14 in) Swivel Grease Nozzle

Part No.	Description	Size
4C-7197	Swivel Grease Nozzle	17.78 cm (7 in)
4C-7212	Swivel Grease Nozzle	35.56 cm (14 in)

- Nozzles have straight 1/8 inch NPT(m), 17.78 cm (7 in) or 35.56 cm (14 in) extension tubes and taper nose coupler
- Coupler has 360° swivel adapter for maximum adaptability



#### 4C-7201 Hose Nozzle

#### 4C-7185 Hose Nozzle with Lock Sleeve Connector

Part Number	Description
4C-7201	Hose Nozzle
4C-7185	Hose Nozzle with Lock Sleeve Connector

- 30.48 cm (12 in) flex hose provides ability to reach difficult-to-reach fittings
- Nozzles include taper nose coupler
- 4C-7201 has 1/8 inch NPT(m) inlet
- 4C-7185 includes lock sleeve connector for quick connection to any greasenozzle having taper nose coupler
- Warning: Potential injection hazard. Not for use above 345 bar (5000 psi)



## 4C-7065 76.2 cm (30 in) Hose Nozzle (Less Coupler)



- 76.2 cm (30 in) flex hose having 1/8 inch NPT(m) both ends
- Use as alternate for rigid nozzle
- Use with taper nose coupler
- Warning: Potential injection hazard. Not for use above 345 bar (5000 psi)

Part Number	Description
4C-7065	Hose Nozzle (Less Coupler)

## Hydraulic Couplers

Warranty: Manufacturer's (See The Graco Warranty)

### 4C-7162 Standard Buttonhead Hydraulic Coupler

### 4C-7163 Giant Buttonhead Hydraulic Coupler

- Gives fast, positive seal on buttonhead fittings
- Choice of two sizes for standard or giant buttonhead fittings
- Both have 1/8 inch NPT(f) inlet

Part Number	Description	Inlet
4C-7162	Standard Buttonhead Hydraulic Coupler	1/8 in NPT(f)
4C-7163	Giant Buttonhead Hydraulic Coupler	1/8 in NPT(f)

## Adapters

Warranty: Manufacturer's (See The Graco Warranty)

### 6V-4057 Hydraulic-To-Push Adapter

### 4C-7222 Hydraulic-To-Steel Needle Adapter

- Adapters have lock sleeve connector for quick connection to any grease nozzle having taper nose coupler
- Use 6V-4057 for U-joints and low pressure service
- Use 4C-7222 for flush fittings

### 4C-7186 360° Grease Swivel with Coupler

### 4C-7178 360° Grease Swivel Only

- Swivels and locks full 360°
- Use for maximum coupler adaptability and reach
- 1/8 inch NPT(f) x 1/8 inch NPT(m)
- 4C-7186 includes taper nose coupler

### 4C-7184 Lock Sleeve Connector

- Allows quick connection to taper nose coupler
- Inlet is standard grease fitting with sleeve to lock connector in place
- Outlet is 1/8 inch NPT(f)

### 4C-7213 Grease Loader Valve

- For use with lever operated high volume grease pumps
- Permits fast bulk refilling of hand-operated grease lever guns equipped with 4C-7214 Easy Fill Valve
- Valve has 3/8 inch NPT(f) inlet

### 4C-7226 Hydraulic Adapter Assortment Pack

- Complete package contains assorted adapters for servicing bearings with plugs and flush fittings: needle adapter, 4C-7224 Plug Adapter, 4C-7222 Hydraulic-to-Steel Needle Adapter, 4C-7185 Whip Hose Nozzle Connector

Part Number	Description
6V-4057	Hydraulic-To-Push Adapter
4C-7222	Hydraulic-To-Steel Needle Adapter
4C-7186	Grease Swivel with Coupler
4C-7178	Grease Swivel
4C-7184	Lock Sleeve Connector
4C-7213	Grease Loader Valve
4C-7226	Hydraulic Adapter Assortment Pack

### Air Operated Diaphragm Pumps

Warranty: Manufacturer's (See The Graco Warranty)

#### 4C-7342 1:1 Husky Diaphragm Pump — 62 lpm (16 gpm)

- With acetal plastic construction, Buna-N seals, and stainless steel trim, this 1:1 diaphragm pump is ideally suited for handling antifreeze and water or windshield wash solvent and water
- It can also be used for short distance transfer of light oils such as ATF and 10 wt. motor oil

#### Accessories for 4C-7342 Pump:

#### 4C-8971 1.82 m (6 ft) Suction Hose 12.7 mm (1/2 in) with Filter Screen

- Permits 4C-7342 pump to be wall mounted using 1.82 m (6 ft) suction tube with a stainless steel filter



4C-7342



4C-8971

Part No.	Description	Detail	Size
4C-7342	Diaphragm Pump	Husky	62 lpm (16 gpm)
<b>Accessories</b>			
4C-8971	Suction Hose	with Filter	1.82 m (6 ft), 12.7 mm (1/2 in)

#### 369-7510 1:1 Husky Diaphragm Pump — 114 lpm (30 gpm)

- Cast aluminum construction and Buna-N seals for use in high volume transfer of light oils and service fluids such as ATF, 10 wt. motor oil, antifreeze or windshield wash solvent
- Can also be used in oil evacuation systems
- CE, UL Compliant



Part No.	Description	Maximum Free Flow Delivery	Maximum Free Flow Air Consumption	Air Pressure Operating Range	Maximum Suction Lift Wet	Maximum Suction Lift Dry	Air Inlet Size	Fluid Inlet Size	Fluid Outlet
369-7510	Husky Diaphragm Pump	114 lpm (30 gpm)	67 scfm	1.4 - 7.0 bar (20-100 psi)	7.62 m (25 ft)	4.87 m (16 ft)	1/2 in NPT (f)	1 in NPT (f)	1 in NPT (f)
<b>Repair Kits</b>									
369-7513	Diaphragm Repair Kit	--	--	--	--	--	--	--	--
369-8144	Air Valve Repair Kit	--	--	--	--	--	--	--	--

## 4C-6786 1:1 Husky Diaphragm Pump — 55 lpm (145 gpm)



- Cast aluminum construction and Buna-N diaphragm seals for use in high volume lubricant fluid transfer

Gallons/cycle	3.02 L (0.8 gal)
Fluid inlet size	2 in NPT(f)
Fluid outlet size	2 in NPT(f)
Air pressure operating range	.7 - 8.4 bar (10 - 120 psi)
Maximum fluid pressure	8.4 bar (120 psi)
Maximum fluid temperature	100° C (212° F)
Maximum pumpable solid size	6.35 mm (1/4 in)
Maximum recommended viscosity	20,000 cps
Maximum suction lift wet	6.096 m (20 ft)
Maximum suction lift dry	4.572 m (15 ft)
Air inlet size	3/4 in NPT(f)
Maximum decibel level	90 dBA
Mounting hole layout	26.41 x 33.78 cm (10.4 x 13.3 in)

Part Number	Description	Maximum Free Flow Delivery	Weight	Size (H x W x D)
4C-6786	Pump (complete)	55 lpm (145 gpm)	Aluminum 33 kg (72.7 lb)	55.88 x 45.72 x 35.56 cm (22 x 18 x 14 in)

## 9U-6771 Used Oil Evacuation System

Warranty: Manufacturer's (See The Graco Warranty)



- Provides a quick and simple method of evacuating used oil from portable roll-around style used oil receivers (not included); included are diaphragm pump, air on-off valving, air regulator and 6 ft suction hose with valving to eliminate spills
- System fully groundable and bondable for safe transfer of waste oil
- Includes 19 mm (3/4 in) UL approved pump, 4C-8854 Filter Regulator, hose and fitting kit, 9U-6772 Receiver Adapter Kit, wall mount bracket, piping kit

### NOTE:

Use locally supplied grounding wires and clamps in accordance with applicable codes. Funnel and drum not included; sold separately.

Part Number	Description
9U-6771	Used Oil Evacuation System
<b>Includes</b>	
4C-8854	Filter Regulator Hose and Fitting Kit
9U-6772	Receiver Adapter Kit



### 9U-6037 Drum-Mounted, Portable Fluid Evacuation System

Warranty: Manufacturer's (See The Graco Warranty)

- Nothing is faster than the evacuation system for routine used fluid disposal — hydraulic oil, motor oil, cutting oils, and coolants
- Drum-mounted, portable fluid evacuation system utilizing UL approved, air-powered double diaphragm pump
- Designed to empty used fluids from hard-to-reach reservoirs on many types of machinery and equipment
- Portable so you can move it wherever on the plant floor is convenient for you and your operation
- No installation required; just connect the air supply
- Use 4C-8854 Filter-Regulator-Lubricator and 9U-6038 Mounting Bracket (not included, sold separately)
- Mounts on a user-supplied 205 L (55 gal) closed head drum
- System includes a pump, hoses, dolly with casters and handle, and a 12.7 x 812.8 mm (1/2 x 32 in) OD nylon wand



Part Number	Description
9U-6037	Drum-Mounted, Portable Fluid Evacuation System

### 9U-6042 Suction Wand Kits for Fas-Vac

Warranty: Manufacturer's (See The Graco Warranty)

- All tubes are nylon unless otherwise specified
- 4-wand kit with 121.92 cm (48 in) tubes — OD 4.76 mm (3/16 in), 6.35 mm (1/4 in), 9.525 mm (3/8 in), 12.7 mm (1/2 in)

Part Number	Description
9U-6042	Suction Wand Kits for Fas-Vac



### 187-1458 QuickEvac Service Kit

#### Essential Tool

Model: Most Cat® Off-Highway Trucks

Warranty: Manufacturer's (See RPM Industries Warranty)

- Saves time on engine oil changes (removes and fills engines with oil)
- Evacuates most engine oil sumps in less than one minute
- Provides environmentally safe oil changes (minimizes oil spillage by pumping oil directly to PM truck or waste container)
- Contributes to increased profit margins
- Quick and easy connections (Flush Faced Quick Disconnects) to machine and/or containers
- Purging tool virtually eliminates oil spillage by removing trapped oil from filter elements and/or oil coolers
- Can be retrofitted to most machines
- Equipped with Deutsch electrical connectors
- Used on machines that have Quick Evac installed on machine

Part Number	Description
187-1458	QuickEvac Service Kit

## 212-7769 Adapter Cart Group

Model: Off-Highway Trucks and Wheel Loaders with a "Service Center"

Warranty: Six Months

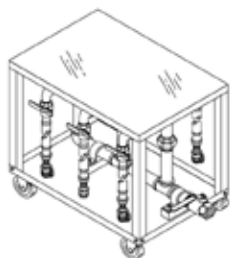

- Used to quickly and easily remove fluids from machines equipped with a "Service Center"
- All fluids can be drained simultaneously into one bulk fluids container
- Unit should not be used to refill fluids due to possible contamination of clean fluids
- Equipped with six clear (see-through) hoses so operator knows when a particular system is completely drained
- 5 different sizes of quick disconnect fittings, with on/off valves, allow connection to almost any fluid port
- 2 inch NPT on/off outlet valve allows users to connect unit into their fluid recovery/pumping system
- Lightweight design with large diameter wheels for easier movement of cart
- Adapter cart is not self-contained

Part Number	Suction Line Length	Suction Line Diameter	Caster Size	Overall size (L x W x H)	Port Designation	Qty.
212-7769	3 m (10 ft)	33 mm (1.3 in)	127 mm (5.0 in) diameter x 32 mm (1.25 in) wide	915 x 623 x 930 mm (36.0 x 24.5 x 36.6 in)	--	--
Quick Disconnect Fittings						
108-5453	--	--	--	--	994 and 793 hydraulic tank	1
126-7538	--	--	--	--	793 and 797 engine or transmission oil	1
126-7539	--	--	--	--	793 and 797 engine oil	2
127-9088	--	--	--	--	793 and 797 hydraulic tank	1
9S-9273	--	--	--	--	994 engine oil	1

## 1P-2850 Oil Drain Cart

Warranty: Six Months



- Low profile and caster mounting
- Can be conveniently positioned under any machine
- Easily transports waste oil from machine to receptacle
- 45 gallon capacity; provided with baffles to prevent sloshing

Item	Part Number	Description
--	1P-2850	Oil Drain Cart
Parts for Oil Drain Cart		
1	8S-9574	Caster
2	5B-7666	Street Elbow 90°
3	8S-9573	Caster (2)

### 148-6740 Oil Receiver

Warranty: Manufacturer's 1 year

- 25 gallon polyethylene tank
- Includes used filter tray, tool holder, and sight gauge
- Provides oversized rear wheels for easy portability
- Front wheels provide swivel casters for mobility
- Color: Black



Part Number	Description
148-6740	Oil Receiver

### Drum Cover and Hold-Down Kit

Warranty: Manufacturer's (See The Graco Warranty)

For: 60.57 L / 54.43 kg (16 gal / 120 lb) Drum

4C-7203 Hold-Down and Cover Kit (Open-Head)

- Cover kit allows center mounting of Fire-Ball or President pumps on 60.57 L / 54.43 kg (16 gal / 120 lb) open head drums
- Hold-down kit can be used with cover kit or separately to secure drums by clamping directly on drum chine
- Includes: cover kit, hold-down kit

Part Number	Description
4C-7203	Hold-Down and Cover Kit

### Lubrication Hose

Warranty: Manufacturer's (See The Graco Warranty)

- Wire reinforced hose
- Use with oils, greases, and undercoating material
- Color: black

Part Number	Length	Fittings
<b>6.35 mm (1/4 in) ID - 345 bar (5000 psi)</b>		
4C-7062	30.48 cm (12 in)	3.175 mm (1/8 in) M x 3.175 mm (1/8 in) M (with Bend Restrictor)
4C-7065	76.2 cm (30 in)	3.175 mm (1/8 in) M x 3.175 mm (1/8 in) M (with Bend Restrictor)
<b>9.525 mm (3/8 in) ID - 276 bar (4000 psi)</b>		
4C-7074	30.48 cm (12 in)	6.35 mm (1/4 in) F x 12.7 mm (1/2 in) M
4C-7075	60.96 cm (24 in)	9.525 mm (3/8 in) M x 9.525 mm (3/8 in) M
4C-7076	121.92 cm (48 in)	9.525 mm (3/8 in) M x 9.525 mm (3/8 in) M
4C-7078	4.572 m (15 ft)	6.35 mm (1/4 in) M x 6.35 mm (1/4 in) M
4C-7079	7.62 m (25 ft)	6.35 mm (1/4 in) M x 6.35 mm (1/4 in) M
4C-7080	12.192 m (40 ft)	6.35 mm (1/4 in) M x 9.525 mm (3/8 in) M
4C-7081	15.24 m (50 ft)	6.35 mm (1/4 in) M x 9.525 mm (3/8 in) M
<b>12.7 mm (1/2 in) ID - 207 bar (3000 psi)</b>		
4C-7337	45.72 cm (18 in)	1/2 in M x 1/2 in M
4C-7335	4.88 m (16 ft)	1/2 in M x 1/2 in M
4C-7336	6.10 m (20 ft)	1/2 in M x 1/2 in M
4C-7341	7.62 m (25 ft)	1/2 in M x 1/2 in M
4C-7354	15.24 m (50 ft)	1/2 in M x 1/2 in M
4C-7334	1.83 m (72 in)	1/2 in M x 1/2 in M

(Continued)

# Lubricating Equipment

## Lubrication Hose (Continued)

Warranty: Manufacturer's (See The Graco Warranty)

Lubricating Equipment

Part Number	Length	Fittings
<b>19.05 mm (3/4 in) ID - 157.5 bar (2250 psi)</b>		
4C-7048	45.72 cm (18 in)	3/4 in M x 3/4 in M
4C-7047	1.83 m (72 in)	3/4 in M x 3/4 in M
<b>Suction Hose</b>		
4C-9019	304.8 cm (12 in)	3/4 in M x 3/4 in M

# Lubricating Equipment

## Lubrication Hose (Continued)

Warranty: Manufacturer's (See The Graco Warranty)

Lubricating Equipment

Part Number	Length	Fittings
<b>19.05 mm (3/4 in) ID - 157.5 bar (2250 psi)</b>		
4C-7048	45.72 cm (18 in)	3/4 in M x 3/4 in M
4C-7047	1.83 m (72 in)	3/4 in M x 3/4 in M
<b>Suction Hose</b>		
4C-9019	304.8 cm (12 in)	3/4 in M x 3/4 in M