

Lifting/Blocking/Clamping

Hoists	11-3
Jacks	11-22
Stands	11-30
Miscellaneous	11-39

Hoists

1U-7485 Heavy-Duty Mobile Lifting Crane, 1996 kg (4,400 lb)

Warranty: Six Months

- Versatile features and rugged construction of OTC heavy-duty crane let you handle just about any lifting job with speed
- Folds into a compact package for storage
- Leg spread adjusts to clear vehicles wheels, other obstacles for close-in work
- Telescoping boom extension gives additional reach
- 2-speed hydraulic hand pump provides fast boom travel (descent of boom is under precise control of operator)
- Equipped with roller-bearing mounted wheels, crane rolls smoothly into position or storage location
- Steering dolly provides easy maneuverability
- Space saving Fold-Away feature

Optional Hydraulics (Sold Separately)

- For greater speed and ease of operation, your crane can be powered with an air-driven, air/hydraulic pump such as the 1U-7544



Capacity, boom extracted	1996 kg (4400 lb)
Capacity, boom extended	1497 kg (3300 lb)
Maximum boom height - Boom extracted	281.9 cm (111 in)
Maximum boom height - Boom extended	309.9 cm (122 in)
Overall height, boom horizontal	208.3 cm (82 in)
Overall length	226.1 cm (89 in)
Minimum throat width	63.5 cm (25 in)
Inside leg length	146.1 cm (57 1/2 in)
Effective boom reach (retracted)	90.22 cm (35 1/2 in)
Effective boom reach (extended)	128.3 cm (50 1/2 in)
Inside leg width (3-position)	66.0 - 101.6 cm (26 - 40 in), 133.4 cm (52 1/2 in)
Leg height	24.13 cm (9 1/2 in)
Dolly wheel diameter	12.7 cm (5 in)
Wheel diameter	20.32 cm (8 in)
Caster diameter	15.24 cm (6 in)
Floor space, folded	78.7 x 106.7 cm (31 x 42 in)
Height, folder	218.4 cm (86 in)
Lifting chain	46.7 cm (18 3/8 in)
Weight	291 kg (642 lb)
Supplier part no.	1820

Part Number	Description
1U-7544	Hydraulic Hand Pump
1U-7485	Heavy-Duty Mobile Lifting Crane, 1996 kg (4,400 lb)

1U-7555 Mobile Lifting Crane, 2,722 kg (6,000 lb)

Warranty: Manufacturer's Two Year Limited



- Heavyweight, retractable-leg, mobile floor crane equipped with electric/hydraulic (115V) pump with remote motor control
- 3 boom positions give you capacities of 1,814, 2,268 and 2,722 kg (4,000, 5,000 and 6,000 lb) — enough to lift the biggest engines
- Features a boom swivel, and extendable legs
- Vertical and lateral swing
- Equipped with an electric/hydraulic pump with remote control for raising and lowering
- Includes a steering dolly for maneuverability; dolly also acts as a floor lock by lifting the rear wheel off the floor
- Built to take all the hard use you can give it
- Ideal for freeing up an overhead crane, letting you pull engines from any bay in the shop
- Offers greater mobility and versatility than installing an overhead crane or gantry
- Coupled with the 6V-3145 Load Leveler (sold separately) and the 1U-5750 Revolver (sold separately) engine stand this crane gives you a complete set of heavy-duty engine equipment

Repair Information

SPX Service Repair

755 Eisenhower Drive

Owatonna, MN 55060

Attn: Repair Department

Phone: 800-344-4013

Visit the SPX Repair Track web link to complete and submit the form for proper authorization: <https://repairtrack.spx.com>

Boom Capacity	Ext. 4,000	Center 5,000	Ret. 6,000
Max. boom height	411.16 cm (161 7/8 in)	382.75 cm (150 11/16 in)	354.33 cm (139 1/2 in)
Min. boom height	15.24 cm (6 in)	44.13 cm (17 3/8 in)	73.03 cm (28 3/4 in)
Overall height, boom horizontal	220.98 cm (87 in)	220.98 cm (87 in)	220.98 cm (87 in)
Overall length	327.98 cm	289.24 cm	249.56 cm
Legs in storage position: 807/8 in	(129 1/8 in)	(113 7/8 in)	(98 1/4 in)
Inside leg length	232.89 cm (91 11/16 in)	193.36 cm (76 1/8 in)	109.86 cm (43 1/4 in)
Effective boom horizontal reach	239.40 cm (94 1/4 in)	200.03 cm (78 3/4 in)	160.66 cm (63 1/4 in)
Outside leg width	151.77 cm	146.69 cm	141.61 cm
Legs in storage position: 531/2 in	(59 3/4 in)	(57 3/4 in)	(55 3/4 in)
Boom swing	91.44 cm (36 in)	78.74 cm (31 in)	66.04 cm (26 in)
Inside leg width	--	90.81 cm (35 3/4 in)	--
Leg height	--	23.02 cm (9 1/16 in)	--
Dolly wheel diameter	--	12.70 cm (5 in)	--
Wheel diameter	--	20.32 cm (8 in)	--
Supplier part no.: 1814			

(Continued)

1U-7555 Mobile Lifting Crane, 2,722 kg (6,000 lb) (Continued)

Warranty: Manufacturer's Two Year Limited

Part Number	Description
1U-7555	Mobile Lifting Crane, 2,722 kg (6,000 lb)

Hand Hoists

Warranty: Manufacturer's Five Year Against Defects In Workmanship

European CE Compliant

- Standard Load Limiter for simple, automatic overload protection
- Weston-style braking system provides reliable positive load control
- Powder coated finish for corrosion protection
- All internal gears and pinions are heat treated steel for high strength and long life.
- Chain guide and stripper assures load chain alignment
- Fully machined precision 4-pocket liftwheel for better chain fit and reduced wear allowing for accurate movement of the load chain
- Hardened alloy steel load chain assures high strength and long wear life
- Minimal maintenance, easily disassembled, requires no special tools
- Meets ASME B30.16 and European CE Standard

Repair Information

Columbus-McKinnon

Audubon and Sylan Parkway

Amherst, NY 14228

Phone: (800) 888-0985

Fax: (716) 689-5644

Website: www.cmindustrial.com

Part Number	Capacity (Tons)	Standard Lift	Approximate Shipping Weight	Shortest Distance Between Hooks	Chain Pull to Lift Load	No. of Chain Falls
398-5484	0.5	3 m (10 ft)	10.4 kg (23 lb)	0.30 m (11.8 in)	44 lb	1
398-5485	1.0	3 m (10 ft)	11.8 kg (26 lb)	0.34 m (13.2 in)	54 lb	1
398-5486	2.0	3 m (10 ft)	20.4 kg (45 lb)	0.40 m (15.6 in)	74 lb	1
398-5487	5.0	3 m (10 ft)	55.3 kg (122 lb)	0.65 m (25.7 in)	76 lb	2
398-5488	10.0	3 m (10 ft)	95.3 kg (210 lb)	0.83 m (32.5 in)	102 lb	3

Electric Chain Hoists

Warranty: Manufacturer's One Year Against Defects In Workmanship

- Heavy-duty motors
- Workings are completely enclosed and compact for low headroom
- Safety features include: Lodestar Protector®, a friction clutch assembly designed to stop the hoist when overloading occurs (a dual braking system — heavy-duty magnetic and regenerative — plus upper and lower limit features)
- Snap action control station carries only 115 volts and is completely sealed, weatherproofed and waterproofed
- Gears receive lifetime lubrication at factory

NOTE:

Due to various applications, suspension for hoist must be ordered separately. Please see part numbers listed under accessories.

Repair Information

Columbus-McKinnon

Audubon and Sylan Parkway

Amherst, NY 14228

Phone: (800) 888-0985

Fax: (716) 689-5644

Web site: www.cmindustrial.com



(Continued)

Electric Chain Hoists (Continued)

Warranty: Manufacturer's One Year Against Defects In Workmanship

Part Number	Max. Capacity	Lifting Speed/Min	Maximum Lift	Motor HP	Electrical Requirements
4C-6953	1/2 ton	4.88 m/min (16 fpm)	4.5 m (15 ft)	1/2 Hp	115 V/1 Phase/60 Hz
4C-6954	1 ton	4.88 m/min (16 fpm)	4.5 m (15 ft)	1 Hp	115 V/1 Phase/60 Hz
4C-6956	2 ton	2.44 m/min (8 fpm)	6.1 m (20 ft)	1 Hp	115 V/1 Phase/60 Hz
4C-6958	3 ton	1.68 m/min (5.5 fpm)	6.1 m (20 ft)	1 Hp	115 V/1 Phase/60 Hz
4C-6959	3 ton	1.68 m/min (5.5 fpm)	6.1 m (20 ft)	1 Hp	230/460 V/3 Phase/60 Hz

Accessories

Part Number	Length of Lift	Use with Hoist
Rigid Hook Suspension		
1U-6362	--	1U-9197, 4C-6954
1U-9812	--	1U-9810, 4C-6958, 4C-6959
1U-6361	--	1U-9195, 4C-6953
Rigid Lug Suspension		
1U-9216	--	4C-6955, 4C-6956
Chain Container		
1U-9561	15 ft	1U-9194, 1U-9196, 1U-9197, 4C-6954
1U-9559	20 ft	1U-9195, 4C-6953
1U-9562	15 ft	4C-6955
1U-9560	20 ft	1U-9197, 4C-6954, 1U-9194, 1U-9196
1U-9813	15 ft	1U-9810, 4C-6958, 4C-6959

362-0960 Spreader Bar Assembly

Warranty: Six Months

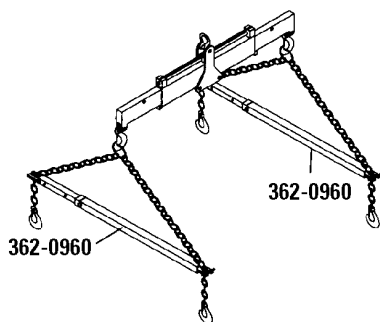

European Union Compliant, CE marked

- Requires double chain sling with 12.7 mm (1/2 in) and 6V-3145 Load Leveler (not supplied with tool)
- Adjustable length from 1067 to 1677 mm (42.0 to 66.0 in) in increment of 76 mm (3.0 in)
- Used with a double sling chain to lift cab vertically at attach points, eliminates side loading
- End pin keeps chain from becoming disengaged when device is being used

Specifications	
Lifting Capacity (WLL)	454 kg (1000 lb)
Adjustable Length	1067 mm (42.0 in) to 1677 mm (66.0 in)
Incremental Adjustment	76 mm (3.0 in)
Tube Size (External)	44.5 mm (1.75 in)
Tube Size (Internal)	38.1 mm (1.50 in)

Part Number	Description
362-0960	Spreader Bar Assembly

6V-3145 Load Leveler

6V-6146 Load Leveler

Warranty: Six Months

- Provides a much improved design over the conventional spreader bar
- Carriage on the main support beam is moved by turning the lead screw, which permits fine adjustment of the tilt angle of the component being lifted
- Lead screw can be turned manually or with air-powered tools
- Spreader bar adjustment is secured with locking bolts
- Chain grade 80 (ASTM)



Item	Part Number	Description	Max. Lifting Capacity	Distance Betw. Hooks Minimum	Distance Betw. Hooks Maximum	Chain Grade (ASTM)	Weight
1	6V-3144	Chain ¹	--	--	--	--	--
--	6V-3145	Load Leveler (Optional)	2,721 kg (5,998.77 lb)	76.2 cm (30 in)	116.8 cm (46 in)	80	34 kg (74.98 lb)
--	6V-6146	Load Leveler	4,535 kg (9,997.95 lb)	91.4 cm (36 in)	142.2 cm (56 in)	80	43.1 kg (95 lb)

¹ Use with 6V-3145 and 6V-6146

309-2793 Load Leveling Assembly

Essential Tool

Model: 994 and 994D Wheel loaders with 3512 Engines, Off-Highway Trucks with C175 Engines, Other similar engine lifting applications
 Warranty: Manufacturer's Limited Lifetime on Lifting Device, Manufacturer's Limited 6 Month on Chain, Wire Rope, and Hoses

European Union compliant, CE marked

- Replaces canceled 137-4370 Leveling Assembly
- Used to lift, level, and position heavy loads such as 3512 and C175 Engines and can also be used on transmissions or other similar components
- Used with overhead lifting device rated for lifting heavy loads
- Adjust and keep load level during lifting procedures by retracting or extending hydraulic cylinder on leveling beam
- Eliminates constant readjustment (raising and lowering) of lifting device to obtain both stable and level load
- Uses heavy-duty, air-over-hydraulic system to allow for small adjustments so load can be accurately positioned during removal and installation
- Increased load rating over previous design allows tooling to be used on more applications
- Includes remote-operation, air-hydraulic switch with 7.62 m (25.0 ft) air hose
- Removable caster assemblies provide mobility for load leveler
- Removable tool box stores and protects remote switch, air hose, and related components
- 310-7787 Wire Rope Assembly may be purchased as replacement for 309-2794 Chain Assembly

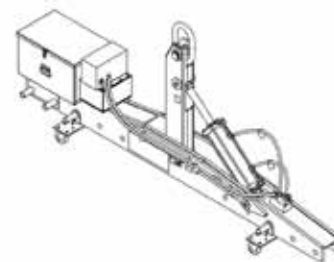

Repair Information

SPX Service Repair
 755 Eisenhower Drive
 Owatonna, MN 55060
 Attn: Repair Department
 Phone: 800-344-4013

(Continued)

309-2793 Load Leveling Assembly (Continued)

Essential Tool

Model: 994 and 994D Wheel loaders with 3512 Engines, Off-Highway Trucks with C175 Engines, Other similar engine lifting applications
 Warranty: Manufacturer's Limited Lifetime on Lifting Device, Manufacturer's Limited 6 Month on Chain, Wire Rope, and Hoses

Visit the SPX Repair Track web link to complete and submit the form for proper authorization: <https://repairtrack.spx.com>

Reference

NEHS1011, Tool Operating Manual, 309-2793 Load Tilter

Capacity	22,680 kg (50,000 lb)
Length	299.7 cm (118.0 in)
Width	29.2 cm (11.5 in)
Height	129.5 cm (51.0 in)
Weight	544 kg (1,200 lb)

Part Number	Description
309-2793	Load Leveling Assembly
Service/Repair Parts	
309-2794	Chain Assembly
309-2795	Air Hose Group (Remote Switch)
310-7787	Wire Rope Assembly

323-1146 Lifting Group

Essential Tool

Model: C175 Engines
 Warranty: Six Months

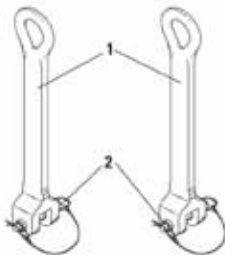

European Union compliant, CE marked

- Used to remove and install C175 Engine Assembly
- Used with 309-2793 Load Leveler
- Sold as complete set — two lifting bars and two 323-1712 Pin Assemblies
- Working Load Limit is stamped into each 323-1146 Lifting Group (Bar)
- Heat-treated for added strength and durability
- 323-1712 Pin Assembly is serviced separately
- Lifting bars are not serviced separately
- Meets the following requirements:
 - ANSI - ASME B30.20:2006
 - AS 4991:2004
 - CE Compliant To Machinery Safety Directive 98/37/EC
 - EN 13155:2003

Reference

NEHS1040, Tool Operating Manual

Item	Description	Quantity
1	Lifting Group (Bar)	2

Item	Part Number	Description	Working Load Limit	Qty.
--	323-1146	Lifting Group	--	--
2	323-1712	Pin Assembly	11,340 kg (25,000 lb)	2

336-7250 Adjustable Lifting Bar

Model: 795F AC Off-Highway Truck, C175 Engine

Warranty: Six Months

European Union compliant, CE marked

- Used to remove and install C175 Engine Assembly on 795F AC Off-Highway Truck
- Used in pairs with 309-2793 Load Leveler (attach at outer pin locations on load leveler)
- Working load limit is stamped into each tool
- Adjustable design allows use in many other lifting applications
- Heat-treated for strength and durability
- Meets the following requirements:
ANSI - ASME B30.20:2006
AS 4991:2004
CE Compliant To Machinery Safety Directive 98/37/EC
EN 13155:2003

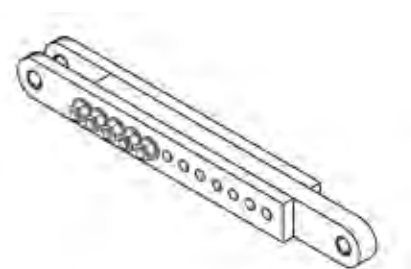

Reference

NEHS1076, Tool Operating Manual

Working load limit	11340 kg (25,000 lb)
Weight	73 kg (161 lb)
Adjustable length	86 to 122 cm (34.0 to 48.0 in) in 5 cm (2.0 in) increments

Part Number	Description
336-7250	Adjustable Lifting Bar

Load Positioners

Warranty: Manufacturer's Two Year Limited

- Used with a crane or hoist
- Useful for tilting heavy or bulky assemblies in confined areas
- For use with floor cranes only. Not to be used with overhead hoists or cranes.
- 138-7575 Link Bracket (2) is part of 9S-9101 and 9S-9100

Reference

NEHS0823, Tool Operating Manual

Repair Information

SPX Service Repair

755 Eisenhower Drive

Owatonna, MN 55060

Attn: Repair Department

Phone: 800-344-4013

Visit the SPX Repair Track web link to complete and submit the form for proper authorization: <https://repairtrack.spx.com>



Part Number	Description	Load Capacity	Chain Size	Chain Length	Chain Grade (ASTM)	Gear Ratio	Drive Size
9S-9101	Sling Assembly	1814 kg (4000 lb)	7.9 mm (5/16 in)	157.48 cm (62 in)	43	82-1	5/8 in Hex
9S-9100	Hoists	907 kg (2000 lb)	6.4 mm (1/4 in)	137.16 cm (54 in)	43	34-1	5/8 in Hex

Warning Tag - Load Positioners

Warranty: Six Months



205-5688 Warning Tag

- Used to warn technician against using load positioner for overhead lifting
- Attach tag to all 9S-9100 and 9S-9101 Sling Assemblies (load positioners) currently in use; required because the chain is grade 43
- Can be ordered free-of-charge

Part Number	Description
205-5688	Warning Tag

Fabric Slings, Protective Sleeve, and Shackles

Model: 769, 773, 777, 785, 789, and 793 Off-Highway Trucks and General Usage

Warranty: Fabric Slings: Manufacturer's Six Months Against Defects In Materials Or Workmanship; Shackle, Spool, and Plate: Six Months

European Union compliant, CE marked (140-7738, 140-7741)

- Used to lift truck bodies or other loads with a hoist or other lifting devices (provides strength of steel without drawbacks of weight, corrosion, or electrical conductivity)
- Reduces number of people required to perform a lift — fiber slings are up to 90% lighter than other rigging materials, can be easily handled by a single person, stored easily, do not require lubrication or reannealing like wire rope or chains, and will not scratch or mar surfaces that they contact
- Helps reduce injuries to mechanics such as hand punctures, pinching, back strain, etc., caused by heavy metal chains and hooks
- Slings provide a high-performance, low-cost method of lifting loads using vertical, basket, and choker-type hitches
- Slings provide the most inspectable lifting device by using double layered, contrasting colors and two types of visible Tell Tail cords to indicate damage
- Added protection can be gained by using a 140-7742 Protective Sleeve when slings are used in severe applications (made of the same bulked nylon material as the outer tubes)
- Sleeves feature velcro closures for easy installation and removal from slings

Construction

- Made from two complete and separate slings (cords), combined into one (provides unique back-up system, in case of failure of either cord)
- Inner load carrying cords are constructed of interwoven high performance fibers which provide excellent chemical resistance and have less than 1% elongation at working load
- Separate inner cords are encased in a double-walled fabric tube — inner tube is made of polyester while outer tube is made of a bulked, abrasion-resistant nylon
- All slings are labeled with model number, serial number, length, load capacities, and warnings

Safety

- 140-7738 and 140-7741 Slings meet all applicable national, international, and industry standards, including, but not limited to: ASME B30.9, ANSI 120.74, and Japanese standards
- 141-0288 and 141-0289 Slings meet all applicable national, international, and industry standards, including, but not limited to: CE Certification and Australian Standards AS4497.1 and AS4497.2
- Contrasting color coded slings provide extra protection and early warning (if red inner tube or cords are visible, the sling should be immediately removed from service and repaired by manufacturer)
- 2 "Tell Tail" cords are used as an indicator of shock or overloading of sling (cords should protrude 13 mm (0.5 in) beyond label tag and if shorter, sling should be returned to manufacturer for evaluation)
- "Fiber Optic Tell Tail" cord is used to determine if inner core fibers are damaged or broken — if light from one end of cord will not shine through to opposite end, the sling is probably damaged and should be returned to manufacturer for evaluation
- All slings are proof-tested to twice their rated capacity

Hardware

- A shackle is used to attach hooks, links, chains, or other lifting systems to fabric slings
- Shackles extra wide contact area gives increased load distribution to sling fabric and allows sling to achieve up to 100% of its rated load lifting capacity
- A spool keeps the loaded hook centered on the shackle pin and spreads lifting load evenly across pin
- A link plate allows attachment of 2 shackles to lifting hook

(Continued)

Fabric Slings, Protective Sleeve, and Shackles (Continued)

Model: 769, 773, 777, 785, 789, and 793 Off-Highway Trucks and General Usage

Warranty: Fabric Slings: Manufacturer's Six Months Against Defects In Materials Or Workmanship; Shackle, Spool, and Plate: Six Months

Repair Information

Alloy Slings

1406 175th Street

Hazelcrest, IL 60429

Phone: (708) 647-4900

Dealer Service Tools 2009

References

REHS0033, Special Instruction, 777D Off-Highway Truck

SEHS9980, Special Instruction, 793C Off-Highway Truck

SEHS9992, Special Instruction 769D/771D Off-Highway Truck

SEHS9993, Special Instruction 773D/775D Off-Highway Truck

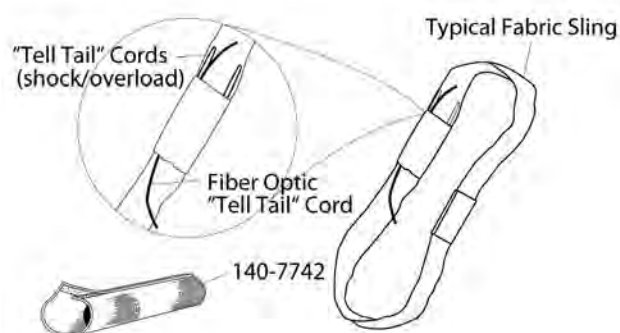

Part Number	Description	Length	Width	Vertical	Lifting Capacity Basket	Choker
140-7738 ¹	Fabric Slings	2.4 m (8.0 ft)	100 mm (4 in)	9,000 kg (2,000 lb)	18,000 kg (40,000 lb)	7,200 kg (16,000 lb)
141-0288 ²	Fabric Slings	2.4 m (8.0 ft)	100 mm (4 in)	9,000kg (20,000 lb)	18,000 kg (40,000 lb)	7,200 kg (16,000 lb)
140-7741 ¹	Fabric Slings	2.4 m (8.0 ft)	75 mm (3 in)	4,500 kg (10,000 lb)	9,000 kg (20,000 lb)	3,600 kg (8,000 lb)
141-0289 ²	Fabric Slings	2.4 m (8.0 ft)	75 mm (3 in)	4,500 kg (10,000 lb)	9,000 kg (20,000 lb)	3,600 kg (8,000 lb)
140-7742 ³	Protective Sleeve	600 mm (24.0 in)	250 mm (10 in)	--	--	--

¹For use in all markets except Europe and Australia

²Required for use in Europe and Australia

³Recommended for use with all Fiber Slings

Fabric Slings, Protective Sleeve, and Shackles

Model: 769, 773, 777, 785, 789, and 793 Off-Highway Trucks and General Usage

Warranty: Shackle, Spool, and Plate: Six Months

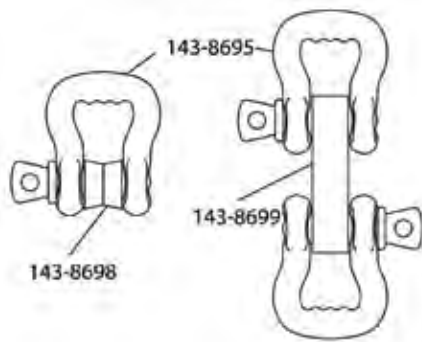

143-8695 Shackle (Synthetic Sling Saver)	
Working load limit	18,600 kg (41,000 lb)
Throat width	54 mm (2.1 in)
Outside length	248 mm (9.8 in)
Maximum sling width	114 mm (4.5 in)
Inside depth	146 mm (5.8 in)
Outside width	191 mm (7.5 in)
Pin diameter	38 mm (1.5 in)
Weight	8.5 kg (18.7 lb)
Material	Alloy steel with threaded screw pin
143-8698 Shackle Spool (Synthetic Sling Saver)	
Outside diameter	63.5 mm (2.5 in)
Width	47.8 mm (1.88 in)
Inside diameter	41.4 mm (1.63 in)
Weight	1.3 kg (2.8 lb)
Material	Alloy steel
143-8699 Shackle Link Plate (Synthetic Sling Saver)	
Working load limit	18,600 kg (41,000 lb)
Thickness	44.5 mm (1.75 in)
Width	76.2 mm (3.0 in)
Length	177.8 mm (7.0 in)
Hole diameter	41.2 mm (1.62 in)
Distance between holes	95.2 mm (3.75 in)
Weight	4.8 kg (10.6 lb)
Material	Alloy steel

Part Number	Description
143-8699	Shackle Link Plate (Synthetic Sling Saver)
143-8698	Shackle Spool (Synthetic Sling Saver)
143-8695	Shackle

Nylon Lifting Slings

Warranty: Six Months

Part No. ¹	Length	Sling Width	Eye Length	Rated No. Of Body Plys	Capacity Choker	Vertical	Basket
Endless Slings (Type V)							
1U-8221	0.91 m (3 ft)	25.4 mm (1 in)	--	1	1125 kg (2480 lb)	1406 kg (3100 lb)	2812 kg (6200 lb)
1U-8222	1.22 m (4 ft)	25.4 mm (1 in)	--	1	1125 kg (2480 lb)	1406 kg (3100 lb)	2812 kg (6200 lb)
1U-8223	1.83 m (6 ft)	25.4 mm (1 in)	--	1	1125 kg (2480 lb)	1406 kg (3100 lb)	2812 kg (6200 lb)
1U-8224	2.44 m (8 ft)	25.4 mm (1 in)	--	1	1125 kg (2480 lb)	1406 kg (3100 lb)	2812 kg (6200 lb)
1U-8225	1.83 m (6 ft)	50.8 mm (2 in)	--	1	2250 kg (4960 lb)	2812 kg (6200 lb)	5625 kg (12400 lb)
1U-8226	2.44 m (8 ft)	50.8 mm (2 in)	--	1	2250 kg (4960 lb)	2812 kg (6200 lb)	5625 kg (12400 lb)
1U-8227	3.05 m (10 ft)	50.8 mm (2 in)	--	1	2250 kg (4960 lb)	2812 kg (6200 lb)	5625 kg (12400 lb)
1U-8228	1.83 m (6 ft)	76.2 mm (3 in)	--	1	3357 kg (7440 lb)	4218 kg (9300 lb)	8437 kg (18600 lb)
1U-8229	2.44 m (8 ft)	76.2 mm (3 in)	--	1	3357 kg (7440 lb)	4218 kg (9300 lb)	8437 kg (18600 lb)
1U-8230	3.05 m (10 ft)	76.2 mm (3 in)	--	1	3357 kg (7440 lb)	4218 kg (9300 lb)	8437 kg (18600 lb)
1U-8231	2.44 m (8 ft)	10.2 cm (4 in)	--	1	4500 kg (9920 lb)	5625 kg (12400 lb)	11249 kg (24800 lb)
1U-8232	3.05 m (10 ft)	10.2 cm (4 in)	--	1	4500 kg (9920 lb)	5625 kg (12400 lb)	11249 kg (24800 lb)
1U-8233	3.66 m (12 ft)	10.2 cm (4 in)	--	1	4500 kg (9920 lb)	5625 kg (12400 lb)	11249 kg (24800 lb)
Eye and Eye Slings (Type III)							
1U-8234	0.91 m (3 ft)	25.4 mm (1 in)	20.3 cm (8 in)	1	562 kg (1240 lb)	703 kg (1550 lb)	1406 kg (3100 lb)
1U-8235	1.22 m (4 ft)	25.4 mm (1 in)	20.3 cm (8 in)	1	562 kg (1240 lb)	703 kg (1550 lb)	1406 kg (3100 lb)
1U-8236	1.83 m (6 ft)	25.4 mm (1 in)	20.3 cm (8 in)	1	562 kg (1240 lb)	703 kg (1550 lb)	1406 kg (3100 lb)
1U-8237	2.44 m (8 ft)	25.4 mm (1 in)	20.3 cm (8 in)	1	562 kg (1240 lb)	703 kg (1550 lb)	1406 kg (3100 lb)
1U-8238	3.05 m (10 ft)	25.4 mm (1 in)	20.3 cm (8 in)	1	562 kg (1240 lb)	703 kg (1550 lb)	1406 kg (3100 lb)
1U-8239	3.66 m (12 ft)	25.4 mm (1 in)	20.3 cm (8 in)	1	562 kg (1240 lb)	703 kg (1550 lb)	1406 kg (3100 lb)
1U-8240	1.22 m (4 ft)	50.8 mm (2 in)	20.3 cm (8 in)	1	1125 kg (2480 lb)	1406 kg (3100 lb)	2812 kg (6220 lb)
1U-8241	1.83 m (6 ft)	50.8 mm (2 in)	20.3 cm (8 in)	1	1125 kg (2480 lb)	1406 kg (3100 lb)	2812 kg (6220 lb)
1U-8242	2.44 m (8 ft)	50.8 mm (2 in)	20.3 cm (8 in)	1	1125 kg (2480 lb)	1406 kg (3100 lb)	2812 kg (6220 lb)
1U-8243	3.05 m (10 ft)	50.8 mm (2 in)	20.3 cm (8 in)	1	1125 kg (2480 lb)	1406 kg (3100 lb)	2812 kg (6220 lb)

(Continued)

Nylon Lifting Slings (Continued)

Warranty: Six Months

Part No. ¹	Length	Sling Width	Eye Length	Rated No. Of Body Plys	Capacity Choker	Vertical	Basket
Eye and Eye Slings (Type III) (Continued)							
1U-8244	3.66 m (12 ft)	50.8 mm (2 in)	20.3 cm (8 in)	1	1125 kg (2480 lb)	1406 kg (3100 lb)	2812 kg (6220 lb)
1U-8245	4.27 m (14 ft)	50.8 mm (2 in)	20.3 cm (8 in)	1	1125 kg (2480 lb)	1406 kg (3100 lb)	2812 kg (6220 lb)
1U-8256	1.83 m (6 ft)	50.8 mm (2 in)	20.3 cm (8 in)	2	2250 kg (4960 lb)	2812 kg (6200 lb)	5625 kg (12400 lb)
1U-8257	2.44 m (8 ft)	50.8 mm (2 in)	20.3 cm (8 in)	2	2250 kg (4960 lb)	2812 kg (6200 lb)	5625 kg (12400 lb)
1U-8258	3.05 m (10 ft)	50.8 mm (2 in)	20.3 cm (8 in)	2	2250 kg (4960 lb)	2812 kg (6200 lb)	5625 kg (12400 lb)
1U-8259	3.66 m (12 ft)	50.8 mm (2 in)	20.3 cm (8 in)	2	2250 kg (4960 lb)	2812 kg (6200 lb)	5625 kg (12400 lb)
Eye and Eye Slings (Tapered Eyes) (Type III) 1							
1U-8246	2.44 m (8 ft)	76.2 mm (3 in)	22.9 cm (9 in)	1	1687 kg (3720 lb)	2109 kg (4650 lb)	4218 kg (9300 lb)
1U-8247	3.05 m (10 ft)	76.2 mm (3 in)	22.9 cm (9 in)	1	1687 kg (3720 lb)	2109 kg (4650 lb)	4218 kg (9300 lb)
1U-8248	3.66 m (12 ft)	76.2 mm (3 in)	22.9 cm (9 in)	1	1687 kg (3720 lb)	2109 kg (4650 lb)	4218 kg (9300 lb)
1U-8249	4.27 m (14 ft)	76.2 mm (3 in)	22.9 cm (9 in)	1	1687 kg (3720 lb)	2109 kg (4650 lb)	4218 kg (9300 lb)
1U-8250	4.88 m (16 ft)	76.2 mm (3 in)	22.9 cm (9 in)	1	1687 kg (3720 lb)	2109 kg (4650 lb)	4218 kg (9300 lb)
1U-8251	3.05 m (10 ft)	10.2 cm (4 in)	25.4 cm (10 in)	1	2250 kg (4960 lb)	2812 kg (6200 lb)	5625 kg (12400 lb)
1U-8252	3.66 m (12 ft)	10.2 cm (4 in)	25.4 cm (10 in)	1	2250 kg (4960 lb)	2812 kg (6200 lb)	5625 kg (12400 lb)
1U-8253	4.27 m (14 ft)	10.2 cm (4 in)	25.4 cm (10 in)	1	2250 kg (4960 lb)	2812 kg (6200 lb)	5625 kg (12400 lb)
1U-8254	4.88 m (16 ft)	10.2 cm (4 in)	25.4 cm (10 in)	1	2250 kg (4960 lb)	2812 kg (6200 lb)	5625 kg (12400 lb)
1U-8255	5.49 m (18 ft)	10.2 cm (4 in)	25.4 cm (10 in)	1	2250 kg (4960 lb)	2812 kg (6200 lb)	5625 kg (12400 lb)
1U-8260	3.05 m (10 ft)	76.2 mm (3 in)	22.9 cm (9 in)	2	3357 kg (7440 lb)	4218 kg (9300 lb)	8437 kg (18600 lb)
1U-8261	3.66 m (12 ft)	76.2 mm (3 in)	22.9 cm (9 in)	2	3357 kg (7440 lb)	4218 kg (9300 lb)	8437 kg (18600 lb)
1U-8262	4.27 m (14 ft)	76.2 mm (3 in)	22.9 cm (9 in)	2	3357 kg (7440 lb)	4218 kg (9300 lb)	8437 kg (18600 lb)
1U-8263	4.88 m (16 ft)	76.2 mm (3 in)	22.9 cm (9 in)	2	3357 kg (7440 lb)	4218 kg (9300 lb)	8437 kg (18600 lb)



WARNING

Inspect sling for damage before each use and remove from service if damaged. Do not overload, cut, or expose to temperatures above 82° C (180° F). Use of damaged sling may result in personal injury.

¹ On wider slings, tapered eyes provide a configuration designed for easier use with chainhooks.

372-5265 Undecking Sling

Model Usage: CT660 Truck

Warranty: Manufacturer's

- Combination nylon and chain sling designed to allow lifting and lowering vehicles, without damaging the front bumper, grille and/or hood

Specifications	
Dimensions	19.8 x 17.1 x 9.8 in
Weight	13.90 kg (30.65 lb)

Part Number	Description
372-5265	Undecking Sling



Columbus McKinnon "Herc-Alloy 800" Chain

Warranty: Six Months

- Manufactured from special alloy steels and engineered for superior combinations of strength, lightness, and durability — qualities that give the "Herc-Alloy 800" system higher working load limits and longer life than conventional alloy chain products, and make it easier to handle
- Embossed approximately every 10 inches with the make (CM) and grade (HA-800) appearing alternately

Part Number	Description	Chain Size	Max. Working Load
4C-6938	Pail, 43.0 m / 18.9 L (141 ft / 5 gal)	7.14 mm (9/32 in)	1,588 kg (3,501 lb)
4C-6939	Pail, 19.2 m / 18.9 L (63 ft / 5 gal)	9.52 mm (3/8 in)	3,221 kg (7,101 lb)
4C-6940	Pail, 12.2 m / 18.9 L (40 ft / 5 gal)	12.7 mm (1/2 in)	5,443 kg (12,000 lb)

WARNING

Serious damage to a chain may occur when a force exceeding the maximum working load limit is applied to a chain or chain assembly. These maximum working load limits are not to be exceeded.

Coupling Links

- Dependable and easy to use for fast assembly on the job, for attaching chain to master links and eye type hooks and for installing new body chain in old slings
- CVSA approved

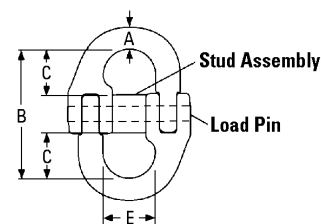

Chain Size	Working Load Limit	Part Number	A	B	C	E ¹	Max. Width	Diameter hole to accept male leg
(9/32 in)	1,588 kg (3,500 lb)	270-0312	7.94 mm (5/16 in)	30.16 mm (1 13/16 in)	15.88 mm (5/8 in)	12.70 mm (1/2 in)	42.86 mm (1 11/16 in)	13.89 mm (3 5/64 in)
(1/2 in)	5,442 kg (11,999 lb)	270-0315	17.46 mm (1 1/16 in)	85.73 mm (3 3/8 in)	30.96 mm (1 7/32 in)	25.40 mm (1 in)	79.38 mm (3 1/8 in)	23.42 mm (59/64 in)
(3/4 in)	12,836 kg (28,300 lb)	270-0316	23.81 mm (1 5/16 in)	121.46 mm (4 25/32 in)	45.64 mm (1 51/64 in)	38.10 mm (1 1/2 in)	109.54 mm (4 5/16 in)	31.75 mm (1 1/4 in)

(Continued)

Coupling Links (Continued)

Chain Size	Working Load Limit	Part Number	A	B	C	E ¹	Max. Width	Diameter hole to accept male leg
(1 in)	21,636 kg (47,699 lb)	270-0320	31.75 mm (1 1/4 in)	146.05 mm (5 3/4 in)	55.56 mm (2 3/16 in)	50.80 mm (2 in)	157.16 mm (6 3/16 in)	39.69 mm (1 9/16 in)
(3/8 in)	3,221 kg (7,101 lb)	363-0795	12.70 mm (1/2 in)	61.12 mm (2 13/32 in)	21.03 mm (53/64 in)	19.05 mm (3/4 in)	56.36 mm (2 7/32 in)	18.65 mm (47/64 in)

¹ Diameter of stock of largest master link intended to be used with Hammerlok

Master Link Sub-Assemblies

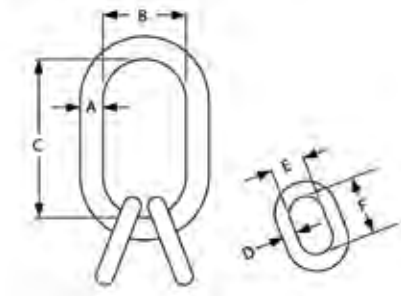

Chain Size	Working Load limit			Master Link Sub-Assembly Number	Diameter Material A	Dimensions	
	60 degrees	45 degrees	30 degrees			Inside Width B	Inside Length C
7.14 mm (9/32 in)	4,128 kg (9,100 lb)	3,357 kg (7,400 lb)	2,359 kg (5,200 lb)	4C-3576	19.05 mm (3/4 in)	69.85 mm (2 3/4 in)	139.70 mm (5 1/2 in)
9.52 mm (3/8 in)	8,346 kg (18,400 lb)	6,849 kg (15,100 lb)	4,808 kg (10,600 lb)	4C-3577	25.40 mm (1 in)	88.90 mm (3 1/2 in)	177.80 mm (7 in)
12.70 mm (1/2 in)	14,152 kg (31,200 lb)	11,567 kg (25,500 lb)	8,165 kg (18,000 lb)	4C-3578	31.75 mm (1 1/4 in)	111.13 mm (4 3/8 in)	222.25 mm (8 3/4 in)

Information to Make Triple and Quad Chain Sling Type

SAFETY NOTE:

A quad branch chain sling usually does not sustain loads with even distribution to its four branches, especially when loads are of rigid structure. Therefore, maximum working load limits are set at the same values as for triple branch chain slings of equal quality and size and used with branches at the same angle of inclination.

(Continued)

Information to Make Triple and Quad Chain Sling Type (Continued)

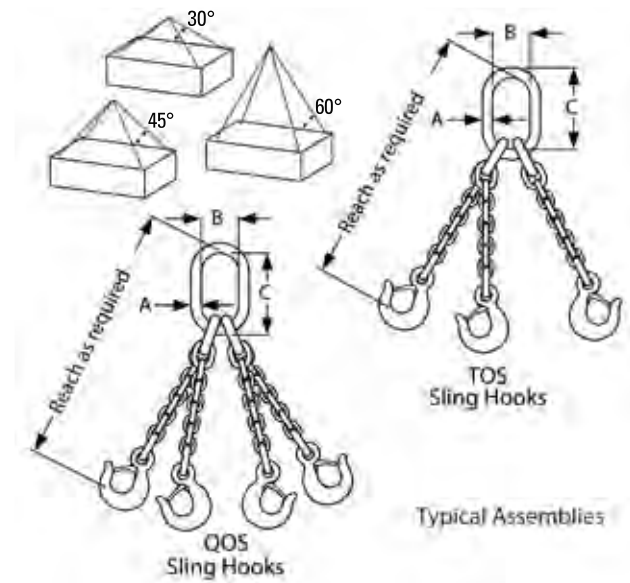

Oblong Master Link

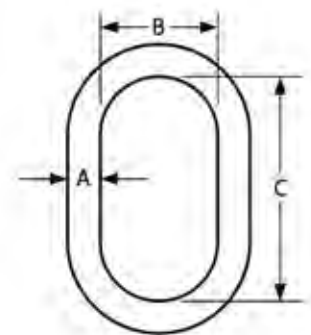

Part Number	Working Load Limit	Link Size			Type and size of chain sling on which used			
		Diameter Material A	Inside Width B	Inside Length C	Single Type S and C	Double Type D	Triple Type T	Quad Type Q
4C-3573	2,767 kg (6,100 lb)	12.70 mm (1/2 in)	63.50 mm (2 1/2 in)	127.00 mm (5 in)	7.14 mm (9/32 in)	7.14 mm (9/32 in)	5.56 mm (7/32 in)	5.56 mm (7/32 in)
4C-3574	5,579 kg (12,300 lb)	19.05 mm (3/4 in)	69.85 mm (2 3/4 in)	139.70 mm (5 1/2 in)	9.53 mm (3/8 in)	9.53 mm (3/8 in)	7.14 mm (9/32 in)	7.14 mm (9/32 in)
4C-3575	9,435 kg (20,800 lb)	25.40 mm (1 in)	88.90 mm (3 1/2 in)	177.80 mm (7 in)	12.70 or 15.88 (1/2 or 5/8 in)	12.70 mm (1/2 in)	9.53 mm (3/8 in)	9.53 mm (3/8 in)

Hoists

Clevlok Sling Hook with Latch

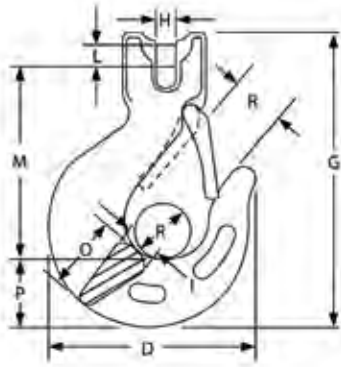

Chain Size	Working Load Limit	Part No.	Dimensions									Replacement Latch Kit
			D	G	H	I	L	M	O	P	R	
7.14 mm (9/32 in)	1,588 kg (3,500 lb)	1U-9795	88.90 mm (3.500 in)	130.96 mm (5.156 in)	8.33 mm (0.328 in)	18.64 mm (0.734 in.)	9.07 mm (0.357 in)	87.30 mm (3.437 in)	30.56 mm (1.203 in.)	26.70 mm (1.051 in)	26.97 mm (1.062 in.)	1U-9798
9.53 mm (3/8 in)	3,220 kg (7,100 lb)	1U-9794	110.31 mm (4.343 in)	169.47 mm (6.672 in)	11.51 mm (0.453 in)	24.21 mm (0.953 in.)	12.88 mm (0.507 in)	113.49 mm (4.468 in)	36.91 mm (1.453 in.)	32.54 mm (1.281 in)	33.32 mm (1.312 in.)	1U-9797
12.70 mm (1/2 in)	5,443 kg (12,000 lb)	1U-9793	139.70 mm (5.500 in)	203.20 mm (8 in)	15.06 mm (0.593 in)	29.77 mm (1.172 in.)	15.88 mm (0.625 in)	133.73 mm (5.265 in)	49.23 mm (1.938 in.)	42.06 mm (1.656 in)	39.67 mm (1.562 in.)	1U-9796

Alloy Eye Hooks - Grab



Part Number	Chain Size	Max. Working Load Limit (lb)
1U-9799	12.70 mm (1/2 in)	5,443 kg (12,000 lb)
1U-9883	7.94 mm (5/16 in)	2,041 kg (4,500 lb)
1U-9884	9.53 mm (3/8 in)	3,221 kg (7,101 lb)
4C-3581	6.35 mm (1/4 in)	1,588 kg (3,500 lb)

253-9937 Chain Sling Identification Tag

Warranty: Six Months

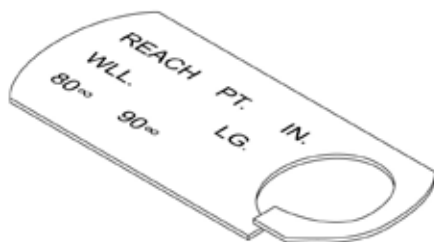

- Used to identify size, grade, rated capacity (WLL), and reach of device
- Use a 6.35 or 9.53 mm (1/4 or 3/8 in) stamp to imprint specifications on tag
- Measures 105 x 38 x 4 mm (4.13 x 1.50 x 0.16 in)
- Opening for chain link: 27 mm (1.06 in) diameter
- Slit opening makes tag easy to attach to a link
- Made from carbon steel
- Meets OSHA Specification 1910.184

Part Number	Description
253-9937	Chain Sling Identification Tag

159-3337 Chain Adjuster, 292-9206 Chain Adjuster (272C)

Essential Tool

Model: 216, 226, 228, 236, 246, 248, 252, 252B, 262C, 246C, 256C and 262 Skid Steer Loaders

Warranty: Six Months

- Used to adjust drive chain tension

Part Number	Description
292-9206	Chain Adjuster (272C)
159-3337	Chain Adjuster

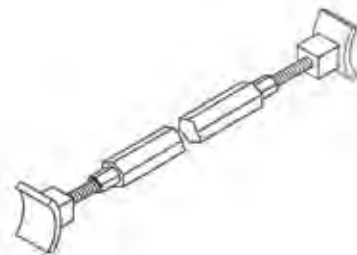

Link Brackets

Model: 5000 Series Mining Excavators and General Usage

Warranty: Six Months

- Used to remove or install large components such as excavator swing gears (provides acceptable method of attaching hoist to component)
- 138-7575 Link Bracket is used specifically to remove and install swing gear and bearing assembly on 5130 and 5230 Mining Excavators
- All link brackets meet ANSI Standards for lifting devices
- Bolts directly onto swing bearing/gear or other component (always use Grade 8 bolts to attach link bracket to component)
- Requires less clearance than standard eyebolt and makes placement/alignment of swing gear/bearing much faster and simpler
- Used for any general purpose lifting where bracket can be attached to component
- 100% proof tested at 2 times the working load limit and complies with the requirements of ANSI/ASME B30.9-1984 as noted on the Certificate of Proof Test contained with each piece

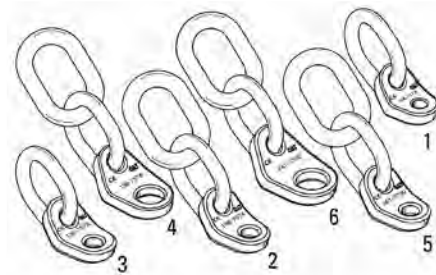

Reference

SEHS9721, Special Instruction, Assembly Procedure for Hydraulic Excavator (5130 only)

NEHS1064 Tool Operating Manual

Item	Part Number	Bolt Size	Working Load Limit	Minimum Bolt Torque
1	138-7573	9.52 mm (3/8 in)	1,000 kg (2,205 lb)	43 N·m (32 ft-lb)
2	138-7574	19.05 mm (3/4 in)	4,000 kg (8,818 lb)	360 N·m (266 ft-lb)
3	138-7575	12.7 mm (1/2 in)	1,800 kg (3,968 lb)	95 N·m (70 ft-lb)
4	138-7576	30 mm (1 1/4 in)	4,000 kg (8,818 lb)	1,300 N·m (959 ft-lb)
5	241-3790	22.225 mm (7/8 in)	4,536 kg (10,000 lb)	620 N·m (457 ft-lb)
6	241-3792	36 mm (1.41 in)	5,448 kg (12,011 lb)	2,700 N·m (1,991 ft-lb)

374-6396 Cylinder Head Lifting Bracket

Model Usage: CT660 Truck, CT11, CT13

Warranty: Manufacturer's



- Used to remove and install the cylinder head on engine

Specifications	
Dimensions	279.4 x 233.7 x 14.0 mm (11.0 x 9.2 x 0.5 in)
Weight	2.42 kg (5.33 lb)

Part Number	Description
374-6396	Cylinder Head Lifting Bracket

Hoist Rings and Anchor Shackle

Essential Tool

Model: 797 Off-Highway Trucks

Warranty: Six Months

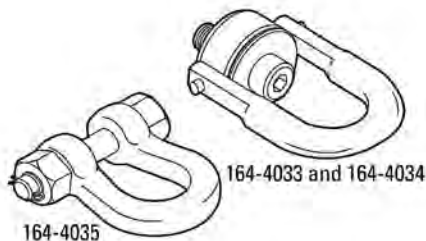

European Union compliant, CE marked

- Used to handle large or heavy components on machines
- Anchor shackle is capable of handling components up to 77 t (85 tons)
- Hoist rings used for lifting differential housing, transmission, spindle group, or axles

Part Number	Description	Load Limit	Bolt Size	Thread Length	Thickness	Width	Inside Diameter	Weight	Material
164-4035	Anchor Shackle	77 t (85 tons)	--	--	92 mm (3.62 in)	127 mm (5 in)	330 mm (13 in)	70 kg (154 lb)	galvanized alloy steel
164-4033	Hoist Ring	7,000 kg (15,432 lb)	M30 x 3.50 x 100 mm (3.9 in) long	45 mm (1.77 in)	--	--	--	--	--
164-4034	Hoist Ring	11,000 kg (24,251 lb)	M36 x 4.00 x 150 mm (5.9 in) long	61 mm (2.40 in)	--	--	--	--	--

Lifting Shackles

Model: All Models

Warranty: Manufacturer's One Year Against Defects In Workmanship

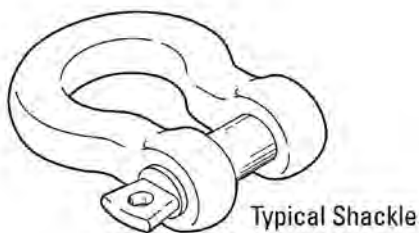

NOTE: Be sure to read and understand the limited warranty that covers this product during the first 12 months following transfer of title to the purchaser. The manufacturer reserves the choice to repair, replace, or refund the purchase price of any product they determine to be defective.

European Union compliant, CE marked

- Used for a variety of lifting applications
- Assorted sizes and capacities for multiple shop or field uses
- Forged, quenched, and tempered
- Each shackle includes an alloy steel screw-pin to secure loads
- Working load limit is permanently imprinted on every shackle

(Continued)

Lifting Shackles (Continued)

Model: All Models

Warranty: Manufacturer's One Year Against Defects In Workmanship

Repair Information

Crosby Group

P.O. Box 3128

Tulsa, OK 74101

Phone: (918) 834-4611

Fax: (918) 832-0940

Email: crosbygroup@earthlink.net

Web site: www.thecrosbygroup.com

Part Number	Description	Working Load Limit
189-0408	Shackle (2 ton)	1,814 kg (4,000 lb)
189-0409	Shackle (3.25 ton)	2,948 kg (6,500 lb)
189-0410	Shackle (4.75 ton)	4,309 kg (9,500 lb)
189-0411	Shackle (8.5 ton)	7,711 kg (17,000 lb)
189-0412	Shackle (9.5 ton)	8,618 kg (19,000 lb)
189-0863	Shackle (12 ton)	10,886 kg (24,000 lb)
193-5474	Shackle (55 ton)	49,895 kg (110,000 lb)
5P-8622	Shackle (6.5 ton)	5,900 kg (13,007 lb)

Tow Straps

Warranty: Six Months

- Ability to take shock — the stretching of the tow strap allows a cushion against sudden shock (nylon strap will stretch 6-8% when loaded at rated capacity and will return to normal length when not loaded)
- Lightweight — tow straps are lightweight, tough, woven nylon that withstand grease, water and multiple folding
- Flexible — tow strap flexibility makes handling in cold weather a snap
- Storage — coiling and storing in vehicle or tool box is simple and easy
- Alloy hooks — tow straps alloy hooks are an integral part of the strap



Part Number	Strap Width	Length	Ply	Breaking Strength	Hook Size
4C-3049	50.8 mm (2 in)	6.10 m (20 ft)	Single	8,890 kg (19,600 lb)	9.53 mm (3/8 in)
4C-3050	50.8 mm (2 in)	7.62 m (25 ft)	2	17,781 kg (39,200 lb)	12.7 mm (1/2 in)

Jacks

Mechanical Screw Jacks, 20 and 24 Ton

Warranty: Manufacturer's Unlimited Against Defects In Materials And Workmanship



- To make leveling work easier, as well as exact, the floating cap on the screw jacks reduce operating friction by 88% over jacks not using this principle
- Non-flattening, single chrome-moly ball gives the cap 9° float to automatically level and center load forces
- Floating cap construction also increases safety, by reducing the possibility of load twist-out (to prevent load slippage, the load cap is serrated)
- No maintenance is required. Housings are of malleable iron to prevent breakage and are flared at the base to help assure stability
- Safety peep hole lets you visually inspect the screw position, reducing the possibility of over extension
- These screw jacks have long been accepted as reliable tools (their sturdy, simple design provides safe support for machinery, general rigging, and construction applications)

Repair Information

Templeton-Kenly
2525 Gardner Road
Broadview, IL 60153
Phone: (800) 323-9114
Fax: (708) 865-0894
Web site: www.tksimplex.com

Part Number	Sustaining Capacity	Closed Height	Operable Rise	Effort per Ton	Handle Base Diameter	Weight	Optional Lever Bar ¹	Lever Bar Length
20 Ton Series								
1U-9324	18,144 kg (20 ton)	30 cm (11 3/4 in)	13 cm (5 in)	6.8 kg (15 lb)	15 cm (6 in)	7.7 kg (17 lb)	4C-4037	91 cm (36 in)
1U-9325	18,144 kg (20 ton)	35 cm (13 3/4 in)	18 cm (7 in)	6.8 kg (15 lb)	15 cm (6 1/2 in)	9 kg (20 lb)	4C-4037	91 cm (36 in)
24 Ton Series								
1U-9327	21,722 kg (24 ton)	43 cm (17 in)	21 cm (8 1/4 in)	6.8 kg (15 lb)	18 cm (7 1/4 in)	16.8 kg (37 lb)	--	1 m (42 in)
1U-9328	21,722 kg (24 ton)	58 cm (23 in)	36 cm (14 1/4 in)	6.8 kg (15 lb)	22 cm (8 1/2 in)	23.6 kg (52 lb)	--	1 m (42 in)

¹ Lever Bar not included as part of screw jack; see Steel Lever Bar chart.

Mechanical Ratchet Lever Jacks, 5 and 10 Ton

Warranty: Manufacturer's Unlimited Against Defects In Materials And Workmanship



5 Ton Series for lowest minimum heights

- Especially suited for moving machinery and for lifting or skidding mine and construction equipment
- Minimum toe height is 44.45 mm (1 3/4 in) on all types of loads; safety speed trigger lets you trip jack instantly when not under load

10 Ton Series for fast, height lifting

- Designed for use with oil and drilling equipment, mining machinery, road building equipment, railroad bolster, and coupler repairs
- Minimum toe heights range from 44.45 mm (1 3/4 in) to 50.8 mm (2 in), with strokes from 24.13 cm (9 1/2 in) to 30.48 cm (12 in); minimum cap heights from 43.18 cm (17 in) to 52.07 cm (20 1/2 in)
- 1U-9322 has a lightweight aluminum alloy housing [weighing just 19.05 kg (42 lb) total] for maximum mobility; malleable-iron cap and large grooved lifting toe [57.15 x 82.55 mm (2 1/4 x 3 1/4 in)] give added safety on all types of loads

(Continued)

Mechanical Ratchet Lever Jacks, 5 and 10 Ton (Continued)

Warranty: Manufacturer's Unlimited Against Defects In Materials And Workmanship

- Housings for other models are of malleable iron and include safety speed trigger for tripping jack when not under load

Repair Information

Templeton-Kenly
 2525 Gardner Road
 Broadview, IL 60153
 Phone: (800) 323-9114
 Fax: (708) 865-0894
 Web site: www.tksimplex.com

Part Number	Capacity	Stroke	Effort per Ton	Handle Capacity Height	Min. Toe Min.	Base Size	Weight	Optional Lever Bar ¹	Lever Bar Length
5 Ton Series									
1U-9320	4536 kg (5 ton)	33 cm (13 in)	33.1 kg (72.97 lb)	51 cm (20.08 in)	44.45 mm (1 3/4 in)	12.7 x 18.7 cm (5 x 7 3/8 in)	15.8 kg (35 lb)	4C-4034	91 cm (36 in)
10 Ton Series									
1U-9321	9071 kg (10 ton)	24 cm (9 1/2 in)	13.6 kg (29.98 lb)	43 cm (17 in)	44.45 mm (1 3/4 in)	15.2 x 22.2 cm (6 x 8 3/4 in)	18.1 kg (40 lb)	4C-4035	1.5 m (60 in)
1U-9322	9071 kg (10 ton)	30 cm (12 in)	13.6 kg (29.98 lb)	52 cm (20.50 in)	50.8 mm (2 in)	16.5 x 26 cm (6 1/2 x 10 1/4 in)	19 kg (42 lb)	4C-4035	1.5 m (60 in)

¹ Lever Bar not included as part of Mechanical Ratchet Lever Jacks; see Steel Lever Bar chart.

1U-9323 Ratchet Lever Jack, 20 Ton Support, 15 Ton Lift

Warranty: Manufacturer's Unlimited Against Defects In Materials And Workmanship

- For easier lifting of heavy loads
- Provides needed lifting capacity for repairing equipment used in heavy construction applications
- Can also be used in pairs in place of an overhead crane to load heavy machinery and equipment
- Easy lifting (just 34 lb handle effort per ton) makes this jack exceptionally suited to both light and heavy applications
- Minimum toe height is 57 mm (2 1/4 in), with 457 mm (18 in) stroke
- Minimum cap height is 718 mm (28 1/4 in)
- Supports 20 tons, lifts 15 tons



Repair Information

Templeton-Kenly
 2525 Gardner Road
 Broadview, IL 60153
 Phone: (800) 323-9114
 Fax: (708) 865-0894
 Web site: www.tksimplex.com

Part Number	Capacity	Stroke	Handle Effort per Ton	Capacity Min. Height	Toe Min.	Base Size	Weight	Optional Lever Bar ¹	Lever Bar Length
1U-9323	18,144 kg (20 ton)	46 cm (18 in)	15.4 kg (34 lb)	72 cm (28 1/4 in)	57.15 mm (2 1/4 in)	20.32 x 27.94 mm (8 x 11 in)	47.17 kg (104 lb)	4C-4036	1.8 m (72 in)

¹ Lever Bar not included as part of Ratchet Lever Jack; see Steel Lever Bar chart.

1U-9330 and 1U-9331 Mechanical Ratcheting Screw Jacks

Warranty: Manufacturer's Unlimited Against Defects In Materials And Workmanship



- 35 and 50 ton capacity
- Low profile for fast lifting, support and exact leveling of heavy loads
- Original journal jacks by Templeton, Kenly and Co., are used widely in all industries where powerful; all-position jacks are required
- Beveled-gear construction combines the best principles of ratchet and screw jacks to give fast lifting and exact leveling of heavy loads, with minimal amount of handle effort per ton
- Low minimum height of these Superjacks makes them ideal for low clearance loads
- Equipped with a fully-enclosed ratchet mechanism, aluminum housings
- Can be lubricated through grease plug, without removing the base

Repair Information

Templeton-Kenly
2525 Gardner Road
Broadview, IL 60153
Phone: (800) 323-9114
Fax: (708) 865-0894
Web site: www.tksimplex.com

Part Number	Capacity	Stroke	Handle Effort per Ton	Min. Height	Base Diameter	Weight	Optional Lever Bar ¹	Lever Bar Length
1U-9330	31,752 kg (35 ton)	13 cm (5 in)	3 kg (7 lb)	26 cm (10 1/4 in)	147 mm (5 1/2 in)	14.5 kg (32 lb)	4C-4034	91.44 cm (36 in)
1U-9331	45,360 kg (50 ton)	10 cm (4 in)	1.8 kg (4 lb)	26 cm (10 5/16 in)	184 mm (7 1/4 in)	27 kg (60 lb)	4C-4039	142.2 cm (56 in)

¹ Lever Bar not included as part of Mechanical Ratcheting Screw Jacks; see Steel Lever Bar chart.

Steel Lever Bars (Sold Separately)

Warranty: Manufacturer's Unlimited Against Defects In Materials And Workmanship

Repair Information

Templeton-Kenly
2525 Gardner Road
Broadview, IL 60153
Phone: (800) 323-9114
Fax: (708) 865-0894
Web site: www.tksimplex.com

Part Number	Length	Weight	For Use With:
4C-4034	91.5 cm (36 in)	3.6 kg (8 lb)	1U-9320 — 5 ton Jack 1U-9330 — 35 ton Jack
4C-4036	182.9 cm (72 in)	9 kg (20 lb)	1U-9323 — 20 ton Jack
4C-4035	15.2 cm (6 in)	7.7 kg (17 lb)	1U-9321 — 10 ton Jack 1U-9322 — 10 ton Jack
4C-4037	91.5 cm (36 in)	3 kg (7 lb)	1U-9324 — 20 ton Jack 1U-9325 — 20 ton Jack
4C-4039	142.2 cm (56 in)	4.5 kg (10 lb)	1U-9331 — 50 ton Jack

1U-7505 Mobile Low Lift Transmission Jack, 2,000 lb

Warranty: Manufacturer's Two Year Limited (Warranty: Six Months — Transmissions Adapters and Mountings)

- Transmission jack and equipment will be direct shipped from Owatana Tool Company
- Permits easy one-man transmission removal and replacement
- Ideal for handling other assemblies, too
- Wide-spaced ball-bearing swivel casters provide exceptional stability and mobility
- Versatile AdjustaGrip mounting arms feature 5-point adjustment, permitting attachment to any unit
- Attachment chains furnished
- Flow control valve slows descent of load
- 3-point screw adjustment allows precise tilting of saddle — essential for proper aligning of transmission with engine
- Saddle rotates 360° for easily servicing transmission after removal from vehicle
- Worldwide reputation for dependability/reliability
- Includes four 1U-7558 mounting arms



Repair Information

SPX Service Repair

755 Eisenhower Drive

Owatonna, MN 55060

Attn: Repair Department

Phone: 800-344-4013

Visit the SPX Repair Track web link to complete and submit the form for proper authorization: <https://repairtrack.spx.com>

Weight	134 kg (297 lb)
Lifting Range	25.4 - 91.44 cm (10 - 36 in)

Part Number	Description	Weight
1U-7505	Jack	--

Transmissions Adapters and Mountings

Part Number	Description	Weight
Transmissions Adapters and Mountings		
1U-7506	Transmission Adapter Kit	4.64 kg (10 15/64 lb)
1U-7558	Transmission Mounting Arm	1.81 kg (4 lb)



4C-4089 Transmission Jack, 1.5 Ton (3,000 lb)

Warranty: Manufacturer's One Year

- Super low clearance — platform can be lowered all the way to the floor
- Smooth rolling — loads move easily on 10.16 cm (4 in) heavy-duty caster wheels
- Convenient hydraulic control — handle can be operated from rear or either side
- Stable lifting platform — 53.34 cm (21 in) wide pivots provide extra stability
- Precise tilt control — adjusts platform in 4 different directions
- Wide base — 78.74 cm (31 in) wide base provides stable support for heavy, bulky loads
- Detachable handle — allows easy movement without limiting access in tight spots
- Adjustable cradles — adapt to different shapes and sizes providing improved stability



(Continued)

4C-4089 Transmission Jack, 1.5 Ton (3,000 lb) (Continued)

Warranty: Manufacturer's One Year

Repair Information

Meyer Hydraulics Corporation
 512-22 W. Burr Oak Street
 Centerville, MI 49032
 Phone: (800) 253-2076,
 (269) 467-6302
 Fax: (269) 467-6897
 Web site: www.meyerhydraulics.com

Capacity	1.5 ton (3,000 lb)
Lift minimum	8.89 cm (3 1/2 in)
Lift maximum	101.6 cm (40 in)
Pad clearance (width)	59.05 cm (23 1/4 in)
Side tilt	9°
Front and rear tilt	25°
Four steel wheel casters	10.16 cm (4 in)
Frame length	114.3 cm (45 in)
Frame width	78.74 cm (31 in)
Frame height	36.83 cm (14 1/2 in)
Weight	133 kg (295 lb)

Part Number	Description
4C-4089	Transmission Jack, 1.5 Ton (3,000 lb)

4C-4090 Drive Train Handler Accessory

Warranty: Manufacturer's One Year



- Accessory from Meyer Hydraulics that adds even more versatility to the transmission jack
- Attaches to the top of the transmission jack platform to steady the difficult-to-handle components
- The wide lifting platform on the transmission jack is ideal for handling:
 - Drive shafts
 - Transfer cases
 - Rear differentials
 - Entire axle assemblies

Repair Information

Meyer Hydraulics Corporation
 512-22 W. Burr Oak Street
 Centerville, MI 49032
 Phone: (800) 253-2076,
 (269) 467-6302
 Fax: (269) 467-6897
 Web site: www.meyerhydraulics.com

Part Number	Description
4C-4090	Drive Train Handler Accessory

5P-3050 Crankcase and Transmission Guard Jack

Warranty: Six Months

- 5P-3050 Jack Group can be used for easy removal and installation of crankcase and transmission guards on any Cat® vehicle
- Attaches directly to the guard at 3 support points; when expandable arm and hook assemblies are detached, the table can be used to support smaller guards
- Also designed to allow relocation of the arm and hook assemblies or attachment of fabricated adapters for other applications



Maximum capacity:	
0 - 10.21 cm (0 - 4 in) lift	2,600 lb (1.3 ton)
10.21 cm (4 in) to maximum lift	4,000 lb (2 ton)
Overall dimensions	
	129.5 x 60.9 cm (51 x 24 in)
Dimensions, maximum - minimum:	
Table height	69.8 - 22.3 cm (27.5 - 8.8 in)
Hook height	142.2 - 52.0 cm (56.0 - 20.5 in)
Width between hooks	132.0 - 76.2 cm (52.0 - 30.0 in)
Length between supports	91.4 - 68.5 cm (36.0 - 27.0 in)

Item ¹	Part Number	Description
--	5P-3050	Crankcase and Transmission Guard Jack
1	5P-3047	15.2 cm (6 in) Swivel Caster (2), 50.8 mm (2 in) wide
2	5P-3048	15.2 cm (6 in) Rigid Caster (2), 50.8 mm (2 in) wide
2	5P-3049	Jack Repair Kit (available separately)

¹Includes Item 3: Capacity Decal SEHS7448

174-6004 Blade Lift Jack (Blade Master)

183-1262 Extension Tube

Model: All products with cutting edges

Warranty: Manufacturer's Two Year Limited

- Used to replace cutting edges on front, wing, and underbody blades in less time and with far less effort
- 1 person can move heavy, awkward cutting edges and comfortably raise them into position
- 183-1262 Extension Tube (sold separately) allows the 174-6004 Blade Lift Jack to handle up to 3.7 m (12 ft) blades with great stability

Repair Information

SPX Service Repair

755 Eisenhower Drive

Owatonna, MN 55060

Attn: Repair Department

Phone: 800-344-4013

Visit the SPX Repair Track web link to complete and submit the form for proper authorization: <https://repairtrack.spx.com>

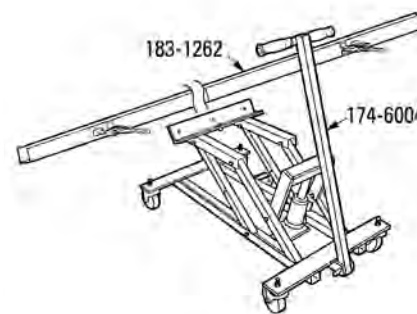

Maximum carrying capacity	113.5 kg (250 lb)
Blade carrying capacity	0.92 - 3.66 m (3 - 12 ft) long
Minimum cradle height	133 mm (5.3 in)
Maximum lifting height	483 mm (19.0 in)
Overall size	597 x 1016 mm (23.5 x 40.0 in)
Weight	36 kg (80 lb)

Lifting/Blocking/Clamping

(Continued)

174-6004 Blade Lift Jack (Blade Master) (Continued)

183-1262 Extension Tube

Model: All products with cutting edges

Warranty: Manufacturer's Two Year Limited

Part Number	Description
183-1262	Extension Tube
174-6004	Blade Lift Jack (Blade Master)

4C-3051 Dual Wheel Dolly

Warranty: Manufacturer's Two Year Limited



- Allows one man to remove, transport and replace heavy truck dual wheel and tire assemblies without strain or struggle
- Ruggedly built unit
- Handles wheels weighing up to 680 kg (1,500 lb), any tire diameter
- Hydraulic jacking mechanism provides full 12.7 cm (5 in) lift; gives serviceman fingertip control when positioning or lowering lifting arms
- 1.83 m (6 ft) chain provided to hold wheel assembly in place during removal and transport
- Free-rolling swivel casters provide effortless maneuverability

Repair Information

SPX Service Repair

755 Eisenhower Drive

Owatonna, MN 55060

Attn: Repair Department

Phone: 800-344-4013

Visit the SPX Repair Track web link to complete and submit the form for proper authorization: <https://repairtrack.spx.com>

Capacity	680 kg (1,500 lb)
Floor space	114.3 x 104.1 cm (45 x 41 in)
Lift travel	12.7 cm (5 in)
Tilt adjustment	2°
Front caster diameter	88.9 mm (3 1/2 in)
Rear caster diameter	10.1 cm (4 in)
Weight	79 kg (175 lb)

Part Number	Description
4C-3051	Dual Wheel Dolly

380-5719 Hydraulic Service Jack, 3.5 Ton

Warranty: Manufacturer one year

- Replaces 1U-9744 Hydraulic Service Jack
- Fast acting pump reaches lifting height in less than a pump to allow user to reach a variety of service height situations quickly
- Universal joint release mechanism
- Rolled side frames resist flexing
- Low profile design allows for easy access under vehicles
- Meets ANSI-PALD standards

380-5719 Specifications	
Capacity, tons (metric ton)	3.5 (3.2)
Low Height	3.75 in (95.2 mm)
Maximum Lift Height	22.0 in (558.8 mm)
Net Weight	103.0 lbs (46.72 kg)
Saddle Diameter	4.25 in (107.9 mm)



159-3175 Hydraulic Jack

Warranty: Six Months

- Replaces discontinued 5P-2385
- Used for quick, easy lift truck service work
- Low initial height, high lifting capacity, small size and weight
- Can be used in shop or field to lift most lift trucks
- Folding handle (when in closed position allows jack to be carried)
- Handle can be locked in vertical position for moving unit across floor

Capacity	3,630 kg (8,000 lb)
Minimum height	57 mm (2.25 in)
Maximum lift height	40.6 cm (16 in)
Weight	29 kg (63 lb)
Length (folded)	79 cm (31 in)
Width	20 cm (8 in)
Height	15.2 cm (6 in)



Part Number	Description	Includes
159-3175	Hydraulic Jack	--
Service/Repair Parts		
4C-9482	Seal Kit	O-ring (7), Seals (2)
4C-9483	Pump Kit	Pump housing, O-ring, seal, plunger

Tune-up and Repair Kits for Discontinued Jacks

- Tune-up kits include blades, gaskets, rings, seals, etc.
- Repair kits include clutch parts plus tune-up kit parts

20-Ton Jacks, 1U-6301 and 1U-5981, both discontinued

1U-5980 Pneumatic Oil Pump Tune-up Kit

50-Ton Jacks, 1U-6303 and 1U-6302, both discontinued

1U-5980 Pneumatic Oil Pump Tune-up Kit

Part Number	Description
1U-5980	Pneumatic Oil Pump Tune-up Kit

Stands

The following vehicle stands are designed for use in pairs and are sold separately.

5P-6215 Stand

Warranty: Six Months

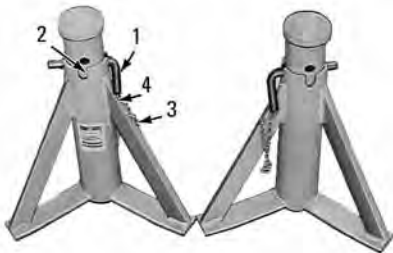

- Designed for use in pairs — sold separately
- For blocking under D3 Tractors and 931 Track-type Loaders
- Can support up to 5 ton (10,000 lb) each
- Adjustable from 368 mm (14.50 in) to 533 mm (21.00 in) in increments of 12.7 mm (0.50 in)
- A positive pin lock furnishes support for the load

Item	Part Number	Description
1	1U-9583	Pin
2	5P-6216	Tube Assembly
3	5P-0149	Chain
4	4B-4161	Screw
--	5P-6215	Stand

417-1324 Support Stand

Warranty: Manufacturer's One Year



- Vehicle support stand
- Sold in pairs
- Tabbed bottom to provide superior stability
- Pin hole design provides multiple height positions

Specifications	
Capacity	7 Tons (each)
Start Height	241.3 mm (9 1/2 in)
Maximum Lift Height	406.4 mm (16 in)
Adjustment Increments	25.4 mm (1 in)
Shipping Weight per pair	14.5 kg (32 lb)

Part Number	Description
417-1324	Support Stand

422-8733 Support Stand

Warranty: Manufacturer's



- Vehicle support stand
- Sold in pairs
- Tabbed bottom to provide superior stability
- Pin hole design provides multiple height positions

Specifications	
Capacity	7 Tons (each)
Start Height	304.8 mm (12 in)
Maximum Lift Height	508 mm (20 in)
Adjustment Increments	25.4 mm (1 in)
Shipping Weight per pair	17.2 kg (38 lb)

Part Number	Description
422-8733	Support Stand

1U-7498 and 1U-7499 Heavy-Duty Support Stands, 12 Ton

Warranty: Six Months

- Designed for use in pairs — sold separately
- Features a spun steel base which won't dig or sink into asphalt or sand
- Extension tubes included, but also available as service repair parts or to convert a Low Boy to a High Boy or visa versa; bases are identical for both models

NOTE:

Order numbers are for individual stands. Customers desiring a pair of stands must order two.



Part Number	Description	Capacity	Weight	Reach
1U-7498	"Low Boy" Stand	12 ton	15 kg (33 1/16 lb)	483 - 750 mm (19 - 29 1/2 in)
1U-7499	"High Boy" Stand	12 ton	18 kg (39 11/16 lb)	857 - 1124 mm (33 3/4 - 44 1/4 in)
Extension Tubes				
1U-7500	For 1U-7499 "High Boy"	--	7.3 kg (16 lb)	--
1U-7501	For 1U-7498 "Low Boy"	--	3.9 kg (8.6 lb)	--

Cat® Lift Stands, 25, 55 and 100 Ton

Warranty: Six Months

European Union compliant, CE marked (277-7200)

Lift and support your largest equipment with these reliable lift stands designed by Caterpillar® and tested to 3 times rated capacity.

- Sold individually but it is recommend they be purchased in pairs
- Infinitely variable blocking range
- Rolls easily on smooth, hard surface — simple to move with a fork lift truck or on attached 12.7 cm (5 in) wheels
- Rugged construction of steel plate and tubing; critical parts are heat treated for durability
- Hydraulic system has 115/230 VAC single-phase 50/60 Hz motor
- Hydraulic system, 277-7200, powers 2 stands at the same time for uniform lifting and lowering
- Tested to 3 times rated capacity
 - exceeds requirements of ASME/ANSI PALD-4C-1991
 - exceeds requirements of Australia Standard AS 2538-1985
- Combines lifting and supporting functions
- Shipped assembled with 6.10 m (20 ft) hose — ready to use
- Completely self storing
- "Flip Over" saddle to match saddle to load point
- Velocity fuse valve prevents sudden dropping of load if pressure loss occurs

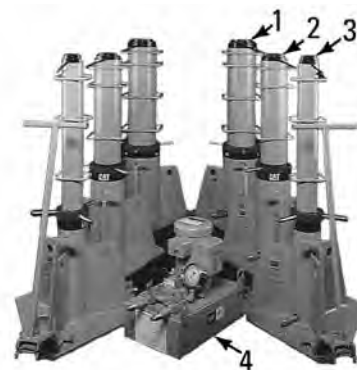

References

NEHS0603, Lift Stand Tool Operating Manual for Service/Repair Parts

NEHS0943, Hydraulic Pump Group

(Continued)

Cat® Lift Stands, 25, 55 and 100 Ton (Continued)

Warranty: Six Months

Item	Part Number	Description	Rated Capacity	Min. Height	Max. Height	Usable Stroke	kPa	psi	Cylinder effective area	Approx. Weight	Base Contact Area
Cat Lift Stands (pictured in pairs, back to front)											
1	9U-7489	Lift Stand, 100 Ton	90,800 kg (100 ton)	634 mm (25.87 in)	1600 mm (62.97 in)	241 mm (9.5 in)	66,798	9695	133 cm ² (20.63 in ²)	390 kg (860 lb)	898 cm ² (139.2 in ²)
2	9U-7536	Lift Stand, 55 Ton	49,940 kg (55 ton)	660 mm (26.0 in)	1613 mm (63.5 in)	318 mm (12.5 in)	68,590	9955	71 cm ² (11.05 in ²)	277 kg (610 lb)	898 cm ² (139.2 in ²)
3	9U-7540	Lift Stand, 25 Ton	22,700 kg (25 ton)	597 mm (23.5 in)	1626 mm (64.0 in)	286 mm (11.25 in)	66,830	9700	33 cm ² (5.15 in ²)	151 kg (333 lb)	898 cm ² (139.2 in ²)
4	277-7200	Hydraulic Pump with 4C-5749 Dolly (optional)	--	--	--	--	--	--	--	--	--

372-5264 Undecking Tool

Model Usage: CT660 Truck

Warranty: Manufacturer's

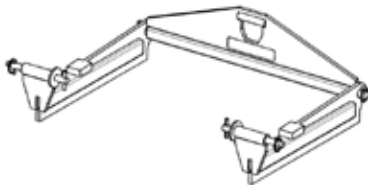

- Used to assure safe and non-destructive undecking of vehicles.

Specifications	
Dimensions	1048 x 630 x 269 mm
Weight	41.3 kg

Part Number	Description
372-5264	Undecking Tool

Cat® Tube Stand Groups, 12, 20, and 25 Ton Capacity

Essential Tool

Model: All

Warranty: Six Months

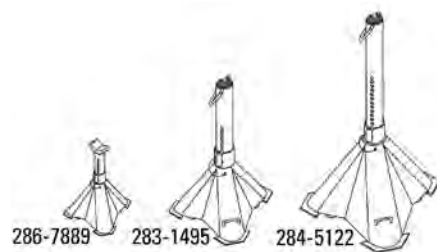

TUV marked

- Used to support (block) track-type or rubber tired vehicles
- Tube stand capacity is rated in US tons, not metric tons
- Used with separate lifting device or hydraulic jacks
- Designed to be used in pairs
- Rugged heavy-duty design with welded, all steel construction
- Meets stability standards and load capacity for AS/NZS 2538:2004, ANSI, PALD, and TUV
- Dual lock-pin design provides 2 load-bearing surfaces
- Adjustable height in 19 mm (0.75 in) increments
- 20 and 25 ton tube stand bases feature retractable spring-loaded casters

References

NEHS0967, 286-7889 Jack Stand Group, 12 Ton Capacity

NEHS0938, 283-1495 and 284-5122 Tube Stand Groups,

20 and 25 Ton Capacity

(Continued)

Cat® Tube Stand Groups, 12, 20, and 25 Ton Capacity (Continued)

Essential Tool

Model: All

Warranty: Six Months

Part Number	Rated Capacity	Minimum Height	Maximum Height	Base Contact Diameter
286-7889	10,886 kg (23,999 lb)	43.2 cm (17.0 in)	72.0 cm (28.3 in) 111.3 cm (43.8 in) medium tube	46.2 cm (18.2 in)
283-1495	18,144 kg (40,001 lb)	59.9 cm (23.6 in) short tube; 86.6 cm (34.1 in) medium tube ¹	84.7 cm (33.3 in) short tube; 111.3 cm (43.8 in) medium tube ¹	65 cm (25.6 in)
284-5122	22,680 kg (50,001 lb)	81.0 cm (31.8 in) short tube; 107.7 cm (42.4 in) medium tube; 125.9 cm (49.5 in) long tube ¹	105.7 cm (41.6 in) short tube; 132.5 cm (52.1 in) medium tube; 171.6 cm (67.5 in) long tube ¹	91.5 cm (36 in)

¹Optional 283-1498 Saddle adds 44 mm (1.7 in) to height when installed

Service/Repair Parts for 286-7889 Jack Stand Group - 12 Ton (US) Capacity

Item	Part Number	Description
Service/Repair Parts for 286-7889 Jack Stand Group - 12 Ton (US) Capacity		
1	286-7892	Base
2	286-7895	Tube
3	286-7896	Lock-Pin
4	4C-6709	Lanyard
--	286-8090	Film Group

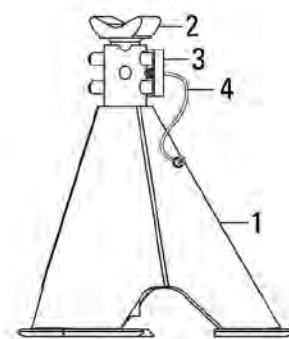

Service/Repair Parts for 283-1495 Tube Stand Group - 20 Ton (US) Capacity

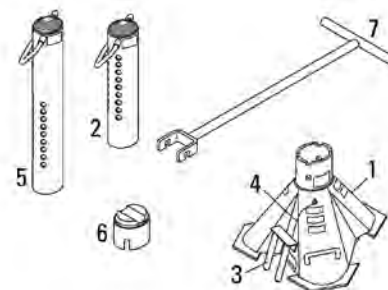

Item	Part Number	Description	Detail
Service/Repair Parts for 283-1495 Tube Stand Group - 20 Ton (US) Capacity			
1	283-1470	Base	--
2	283-1478	Tube, 594 mm (23.4 in)	--
3	283-1500	Lock-Pin	--
4	4C-6709	Lanyard	--
--	287-2094	Film Group	--
Optional Items			
5	283-1482	Tube, 84.1 cm (33.1 in)	Increases height capability of tube stand
6	283-1498	Saddle	Fits over tube and locates load on center of tube stand (adds 44 mm [1.7 in] to height)
7	277-7195	Handle	Attaches for quick and easy positioning of tube stands

Lifting/Blocking/Clamping

Service/Repair Parts for 284-5122 Tube Stand Group - 25 Ton (US) Capacity

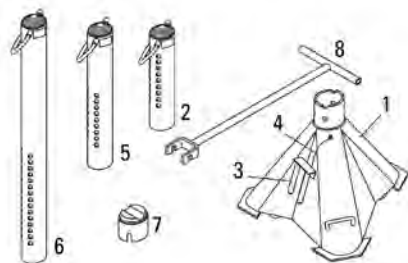

Item	Part Number	Description	Detail
Service/Repair Parts for 284-5122 Tube Stand Group - 25 Ton (US) Capacity			
1	283-1480	Base	--
2	283-1478	Tube, 594 mm (23.4 in)	--
3	283-1500	Lock-Pin	--
4	4C-6709	Lanyard	--
Optional Items			
5	283-1482	Tube, 84.1 cm (33.1 in)	Increases height capability of tube stand
6	283-1493	Tube, 128.0 cm (50.4 in)	Increases height capability of tube stand
6	283-1498	Saddle	Fits over tube and locates load on center of tube stand (adds 44 mm [1.7 in] to height)
7	277-7195	Handle	Attaches for quick and easy positioning of tube stands

⚠ WARNING

Do not use 283-1493 Long Tube with 283-1470 Base. This combination of parts can result in an unstable load, which could cause serious injury or death.

Tube Stands

Warranty: Six Months



- Used to lift and block track-type or rubber tired vehicles within their specified capacities
- Can also be used with the 9S-0019 Tractor Lifts for blocking after the lifts have raised the tractor
- Chart lists the proper selection of tools that will provide a lifting range from 32.39 to 212.73 cm (12.75 to 83.75 in); lifting capacity is 20 tons for each stand and 25 tons for each cylinder and base combination — using a suitable hydraulic pump with these tools, it is possible to lift and block most vehicles in about five minutes)
- Hydraulic pumps that will efficiently operate these tools must have a maximum output pressure of 69,000 kPa (10,000 psi)

Item	Part No.	Description	Lifting Only Tool Height		Blocking Only Tool Height		Lifting and Blocking Tool Height		
			32.4 - 69.9 cm (12.75 - 27.5 in)	51.4 - 88.9 cm (20.25 - 35.0 in)	49.5 - 77.5 cm (19.50 - 30.5 in)	74.9 - 101.6 cm (29.48 - 40.0 in)	85.1 - 137.8 cm (33.50 - 54.25 in)	121.9 - 174.6 cm (48.00 - 68.75 in)	160.0 - 212.7 cm (63.00 - 83.75 in)
1	8S-7641	Tube	--	--	--	--	--	--	1
2	4C-6486	Stand ¹	--	--	--	1	1	1	1
3	8S-7631	Tube	--	--	--	--	--	1	--
4	8S-7640	Stand ²	--	--	1	--	--	--	--
5	8S-7621	Tube	--	--	--	--	1	--	--
6	8S-7620	Base Assembly	--	1	--	--	--	--	--

(Continued)

Tube Stands (Continued)

Warranty: Six Months

Item	Part No.	Description	Lifting Only Tool Height		Blocking Only Tool Height		Lifting and Blocking Tool Height		
			32.4 - 69.9 cm (12.75 - 27.5 in)	51.4 - 88.9 cm (20.25 - 35.0 in)	49.5 - 77.5 cm (19.50 - 30.5 in)	74.9 - 101.6 cm (29.48 - 40.0 in)	85.1 - 137.8 cm (33.50 - 54.25 in)	121.9 - 174.6 cm (48.00 - 68.75 in)	160.0 - 212.7 cm (63.00 - 83.75 in)
7	8S-7610	Base Assembly	1	--	--	--	--	--	--
8	8S-7611	Tube	--	--	1	1	--	--	--
9	396-9840	Cylinder	1 ³	1 ³	--	--	1 ⁴	1 ⁴	1 ⁴
10	8S-7625	Collar	--	--	--	--	1	1	1
11	8S-8048	Saddle	--	--	1 ⁵	1 ⁵	1 ⁵	1 ⁵	1 ⁵
12	8S-7615	Pin	--	--	1	1	2	2	2
13	8S-7645	Hose Group	1 ⁶	1 ⁶	--	--	--	--	--
Not Shown									
6	1S-8937	Valve - Needle	1	--	--	1	1	1	--
--	4C-6562	Double Pin Assembly with Lanyard (used with 4C-6486 Stand)	--	--	--	--	--	--	--
--	9S-1557	Saddle	1 ³	1 ³	--	--	1 ⁴	1 ⁴	1 ⁴

¹ Includes: NEEG2453 Warning Decal and NEEG2001 Cat® Logo Decal

² Includes: NEEG2025 Warning Decal

³ Lifting capacity of 396-9840 Cylinder used with the 8S-7620 or 8S-7610 Base Assembly is 25 ton (50,000 lb at 10,000 psi).

⁴ Lifting capacity of 396-9840 Cylinder with offset 8S-7640 Stand is 20 ton (40,000 lb at 10,000 psi).

⁵ Saddle (8S-8048) is used for lifting against convex surfaces.

⁶ Hose (8S-7645) required if two cylinders are used with one pump.

Specifications for all Pumps for Use on Double and Single Acting Hydraulic Cylinders (396-9840) Electric Operated Pumps

Part Number	Voltage	Line Frequency	Reservoir Capacity	Motor HP	Maximum Pressure	Oil Delivery (cu in/min)				Control
						100 psi	1,000 psi	5,000 psi	10,000 Valve	
2P-5500	230	50-60	1.70 L (0.45 gal)	1/2	69,000 kPa (10,000 psi)	170	32	25	18	3-Position
2P-5550	115	50-60	1.70 L (0.45 gal)	1/2	69,000 kPa (10,000 psi)	--	--	--	--	--
1U-7520	115	50-60	7.57 L (2.0 gal)	1/2	69,000 kPa (10,000 psi)	--	--	--	--	4-Way
3S-6224	115	50-60	7.57 L (2.0 gal)	1 1/8	69,000 kPa (10,000 psi)	--	--	--	--	Manual
8S-8033	230	50-60	7.57 L (2.0 gal)	1 1/8	69,000 kPa (10,000 psi)	650	80	70	55	--
1U-5555	115	60	7.57 L (2.0 gal)	1 1/2	69,000 kPa (10,000 psi)	--	--	--	--	--
1U-5565	230	50	7.57 L (2.0 gal)	1 1/2	69,000 kPa (10,000 psi)	425	45	45	45	4-Way

Lifting/Blocking/Clamping

(Continued)

Specifications for all Pumps for Use on Double and Single Acting Hydraulic Cylinders (396-9840) (Continued)

Electric Operated Pumps

Part Number	Voltage	Line Frequency	Reservoir Capacity	Motor HP	Maximum Pressure	Oil Delivery (cu in/min)			Control	
						100 psi	1,000 psi	5,000 psi		
4C-5080	230	60	7.57 L (2.0 gal)	1 1/2	69,000 kPa (10,000 psi)	425	45	45	45	Solenoid

Specifications for all Pumps for Use on Double and Single Acting Hydraulic Cylinders (396-9840)

Air Operated Pumps

Part Number	Air Requirement	Reservoir Capacity	Motor HP	Maximum Pressure PSI	Oil Delivery (cu in/min)			Control Value
					0 psi	5,000 PSI	10,000 PSI	
1U-7522	50 cfm at (80 psi)	7.57 L (2.0 gal)	3	69,000 kPa (10,008 psi)	465	50	25	3-Position 4-Way

Specifications for all Pumps for Use on Double and Single Acting Hydraulic Cylinders (396-9840)

Hand Pumps

Pump Part Number	Reservoir Capacity	Maximum Pressure at 1st Stage and 2nd Stage	Volume Per Stroke	Control Value	For Use With:
1U-7544	140 cu in	1st Stage, 2069 kPa (300 psi) - 2nd Stage, 69,000 kPa (10,000 psi)	38.51 cc (2.35 cu in) - 2.41 cc (0.147 cu in)	Built in - 2-Way	Single Acting Rams
1U-5230	55 cu in	69,000 kPa (10,000 psi)	2.62 cc (0.160 cu in)	--	Single Acting Rams

FT0890 Tube Holder



- Used to safely store and move the tubes for the 4C-6489 and the 8S-7640 Jack-stands
- Fabricate an FT0890 Tube Holder and attach it to the 8S-9901 Tool Cart

1U-7502 Heavy Duty Repair Stand, 907 kg (2,000 lb)

Warranty: Six Months

- Adjustable universal mounting arms (4) enable you to mount an endless variety of engines, transmissions, torque converters, rear axles and other components, without special adapters being necessary.
- Component solidly cradled in stand, supported from both sides, just as it is in vehicle
- Twin-post design, featuring laterally-adjustable outboard support, provides extremely stable workholding unit
- Gearbox allows full rotation of mounted unit for service, with just a turn of the crank — locks in position
- Mounted on wheels and casters, can be easily maneuvered from storage to work area
- Locking rear wheels anchor the stand at the desired work locations



Part No.	Description	Capacity	Weight
1U-7502	Heavy Duty Repair Stand, 907 kg (2,000 lb)	907 kg (2,000 lb)	127 kg (280 lb)

178-8906 Transmission Bracket

Model: 950 Wheel Loader

Warranty: Six Months

- Used to mount constant mesh countershaft transmissions
- Used with 1U-7502 Heavy Duty Repair Stand, 907 kg (2,000 lb)
- Transmission can be rotated 180 degrees for complete disassembly and repair

Part Number	Description
1U-7502	Heavy Duty Repair Stand, 907 kg (2,000 lb)
178-8906	Transmission Bracket



1U-7506 Transmission Adapter Kit

Warranty: Six Months

- Complete with mounting hardware for use on 1U-9352 and 1U-7502 Engine Stands
- Converts your engine stand into a transmission service stand in a matter of minutes
- Replaces the adjustable arms of the stand to hold and position the transmission for repair or overhaul
- Transmission is held at workbench height with 3 sides fully exposed for working convenience; and it can be rotated a full 360° for complete access to all parts
- Weight: 4.65 kg (10 lb, 4 oz)

Part Number	Description
1U-7506	Transmission Adapter Kit

319-1845 Phase Module Lifting Device

Essential Tool

Model: 795F AC Off-Highway Truck

Warranty: Six Months

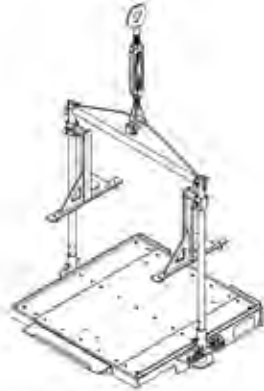

European Union compliant, CE marked

- Used to remove and install various inverter cabinet component
 - DC Power Bus Capacitor
 - Retarding Contactor Tray Assembly
 - Phase Module
- Used with a suitable overhead lifting device
- Lifting point turnbuckle allows small height adjustments to align tooling with inverter cabinet compartment
- Alignment plate secures lower tray to inverter cabinet
- Sliding brackets and threaded holes provide a method of securing components to the lower tray during removal and installation (includes required hardware, stored on the tooling)
- Lower tray has UHMW pads to allow components to easily slide in and out of inverter cabinet
- Lower tray is designed to separate from tooling to allow phase module to be lifted out of or lowered into shipping container

Reference

KENR8715, 795F AC Off-Highway Truck, Power Train, Disassembly and Assembly

NEHS1078, Tool Operating Manual, 319-1845 Phase Module Removal Tool

Part Number	Description
319-1845	Phase Module Lifting Device

Miscellaneous

Tractor Lift

Warranty: Six Months

- Using the tractor lifts illustrated, any track-type vehicle can be raised and blocked by 2 men in 3 to 5 minutes
- Each tractor lift has a curved base 30.48 cm (12 in) wide and has 45.72 cm (18 in) radius which rolls easily on any concrete floor
- Tractor lift consists of four 9S-0027 Lift Assemblies



Also Includes:		
Item	Description	Quantity
2	Wheel	2

Item	Part Number	Description	Capacity	Quantity
1	9S-0027	Lift Assembly	30 ton	4

1U-9724 Columbus-McKinnon Drop Forged Load Binder (Overcenter)

Warranty: Manufacturer's One Year Against Defects In Materials And Workmanship

- All steel
- Drop forged
- 360° swivel
- Each binder individually proof tested
- Short reach for maximum take-up
- Tie-down hole in handle
- Special manufacturing permits use with transport grade 70 chain

**Repair Information**

Columbus-McKinnon

Audubon and Sylan Parkway

Amherst, NY 14228

Phone: (800) 888-0985

Fax: (716) 689-5644

Web site: www.cmindustrial.com

Cat Part Number	Supplier Part Number	Description	Working Load Limit	Chain Size	Take-up	Net Weight
1U-9724	320105	Overcenter Load Binder	2,449 kg (5,400 lb)	7.93 mm (5/16 in) Grade 70, 9.52 mm (3/8 in) Grade 43	10.8 cm (4.25 in)	3.62 kg (8 lb)

⚠ WARNING

Serious damage to a chain may occur when a force exceeding the maximum working load limit is applied to a chain assembly. The maximum working load limits are not to be exceeded.

Lever Hoists

Model Usage: All models

Warranty: Manufacturer's Five Year



European Union compliant, CE marked

- Capacities from 3/4 to 6 tons
- Impact resistant, stamped steel frame, gear case and cover for durability and light weight
- Powder coated finish for added corrosion protection
- Hardened steel load sharing gears
- Double pawl arrangement for assured load control
- Two chain guide rollers for positive chain
- Weston type braking system for positive load control and positioning
- Simple one-handed, free chaining for fast load attachment
- Hardened steel chain for strength and long wear life
- Forged upper and lower hooks with heavy cast steel latches
- Rubber handle grip for added operator comfort
- Minimal maintenance with the special tools required
- Metric rated
- Meets ASME B30.21 – Manually Lever Operated Hoist Standard

Repair Information

Columbus-McKinnon

Audubon and Sylan Parkway

Amherst, NY 14228

Phone: (800) 888-0985

Fax: (716) 689-5644

Web Site: www.cmindustrial.com

Lever Hoists

Part Number	Max. Rated Capacity	Standard Lift	Pull to Lift Load	Shipping Weight	Min. Distance Between Breaks	Handle Length	Hook Throat Opening
386-6030	3/4 Ton ¹	1.5 m (4.99 ft)	15 kg (33.07 lb)	9.1 kg (20 lb)	32.0 cm (12 19/32 in)	28.0 cm (11 in)	28.6 mm (1 1/8 in)
386-6031	3/4 Ton ¹	3 m (9.97 ft)	15 kg (33.07 lb)	9.1 kg (20 lb)	32.0 cm (12 19/32 in)	28.0 cm (11 in)	28.6 mm (1 1/8 in)
386-6032	1 1/2 Ton ¹	1.5 m (4.99 ft)	23.1 kg (50.93 lb)	13.6 kg (29.98 lb)	37.8 cm (14 7/8 in)	41.3 cm (16.25 in)	31.8 mm (1 1/4 in)
386-6033	1 1/2 Ton ¹	3 m (9.97 ft)	23.1 kg (50.93 lb)	15.4 kg (33.95 lb)	37.8 cm (14 7/8 in)	41.3 cm (16.25 in)	31.8 mm (1 1/4 in)
386-6034	3 Ton ¹	1.5 m (4.99 ft)	35 kg (77.16 lb)	29.5 kg (65.04 lb)	47.7 cm (18 25/32 in)	41.3 cm (16.25 in)	39.7 mm (1 9/16 in)
386-6035	3 Ton ¹	3 m (9.97 ft)	35 kg (77.16 lb)	29.5 kg (65.04 lb)	47.7 cm (18 25/32 in)	41.3 cm (16.25 in)	39.7 mm (1 9/16 in)
386-6036	6 Ton ²	1.5 m (4.99 ft)	35 kg (77.16 lb)	35 kg (77.16 lb)	59.0 cm (23 15/64 in)	41.3 cm (16.25 in)	55.6 mm (2 3/16 in)

¹ 1 chain strand

² 2 chain strands

Hoist Accessories

Part Number	Description	Chain Size	For Use With Lever Hoist
386-6037	Friction Disk	--	386-6030, 386-6031
386-6038	Friction Disk	--	386-6032, 386-6033
386-6039	Friction Disk	--	386-6034, 386-6035, 386-6036
386-6040	Replacement Load Chain x 9.14 m (30 ft)	6 x 18 - T (8)	386-6030, 386-6031
386-6041	Replacement Load Chain x 9.14 m (30 ft)	8 x 24 - T (8)	386-6032, 386-6033
386-6042	Replacement Load Chain x 9.14 m (30 ft)	10 x 30 - T (8)	386-6034, 386-6035, 386-6036
386-6340	Upper Hook	--	386-6030, 386-6031
386-6341	Lower Hook Assembly	--	386-6030, 386-6031
386-6342	Upper Hook	--	386-6032, 386-6033
386-6343	Lower Hook Assembly	--	386-6032, 386-6033
386-6346	Upper Hook	--	386-6034, 386-6035
386-6347	Lower Hook Assembly	--	386-6034, 386-6035
386-6358	Upper Hook	--	386-6036
386-6359	Lower Hook Assembly	--	386-6036

1U-9722 and 1U-9723 Columbus-McKinnon Ratchet-Type Binder

- All steel
- Heavy-duty
- Short reach for maximum take-up
- Continuous take-up
- Infinite adjustment
- Meets DOT specifications



1U-9722 and 1U-9723

Cat Part Number	Supplier Part Number	Description	Working Load Limit	Chain Size	Take-up	Net Weight
1U-9722	D48365	Ratchet Binder	2,449 kg (5,399 lb)	7.93 mm (5/16 in) Grade 70, 9.52 mm (3/8 in) Grade 43	20.32 cm (8 in)	5.66 kg (12 1/2 lb)
1U-9723	D48366	Ratchet	4,173 kg (9,200 lb)	9.52 mm (3/8 in) Grade 70, 12.7 mm (1/2 in) Grade 43	20.32 cm (8 in)	5.55 kg (12 1/4 lb)

Load Binder Chain Assembly and Accessories

Cat Part Number	Chain Size	Max. Working Load	Description
1U-9809	9.5 mm (3/8 in)	2,449 kg (5,399 lb)	Grade 43 Load Binder Chain, 6.09 m (20 ft) long with a grab hook at each end (not to be used for lifting chain)
4C-6961	7.9 mm (5/16 in)	2,131 kg (4,698 lb)	Grade 43 Load Binder Chain, 6.09 m (20 ft) long with a grab hook at each end (not to be used for lifting chain)

8S-9906 Ratchet Puller

5P-9694 Ratchet Puller

Warranty: Six Months



- Used for many pulling operations within their capability
- Capacities are given below

Part No.	Description	Lifting Capacity	Single line capacity	Double line capacity
8S-9906 Ratchet Puller (used with track tool cart)				
8S-9906	Ratchet As - Puller	510 - 453 kg (1125 - 1000 lb)	--	--
5P-9694 Ratchet Puller				
5P-9694	Hoist - Ratchet	--	771 kg (1,700 lb)	1,542 kg (3,400 lb)

372-5261 Steering Wheel Puller

Model Usage: CT660 Truck

Warranty: Manufacturer's

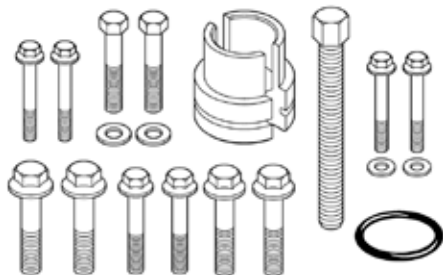

- Used to properly remove steering wheel during service

Specifications	
Dimensions	5.4 x 4.3 x 3.2 in
Weight	1 kg

Part Number	Description
372-5261	Steering Wheel Puller

FT2977 Skid Plate Assembly

Essential Tool

Model: RM350B and other Road Reclaimers

Warranty: None

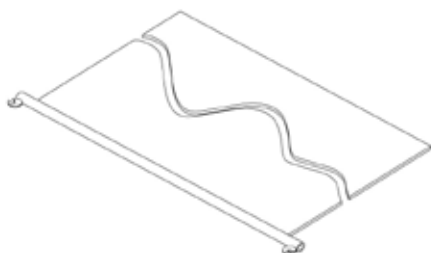

- Provides an alternative method of removing rotor chamber
- Skid plate prevents damage as component is removed from machine

Reference

KENR3127, RM350B Disassembly and Assembly Manual

FT0600 Cable Saver Blocks

Warranty: None

- Used for cable-lifting any square section item
- Will accommodate any size cable and protect it from damage on sharp corners

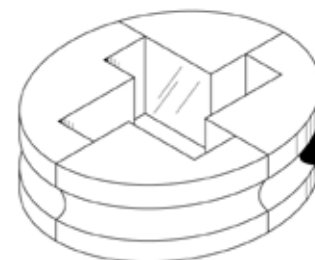

376-4554 Truck Body Lifting Pin

376-4556 Truck Body Lifting Pin

Model: All Off-Highway Trucks

Warranty: Six Months

CE Compliant

- Used to remove and install truck bodies on Off-Highway Trucks
- Available as individual groups
- 376-4554 used on 785, 789, 793, 795, 797
- 376-4556 used on 770 (formerly the 769), 772 (formerly the 771), 773, 775, 777
- Groups consist of 4 pins and 4 shackles
- Pins available separately
 - 376-4553 long replacement pin
 - 376-4555 short replacement pin

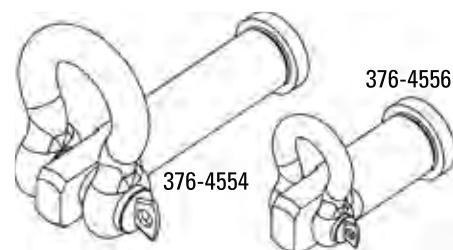

Reference

NEHS1120, Tool Operating Manual

376-4554 Truck Body Lifting Pin	
Working Load Limit	18000 kg (39683.16 lb)
Weight (individual)	48.65 kg (107.25 lb)
Weight (group)	194.6 kg (429 lb)
Dimensions	510.9 x 127 mm (20.11 x 5 in)
376-4556 Truck Body Lifting Pin	
Working load Limit	7000 kg (15432.34 lb)
Weight (individual)	21.61 kg (47.64 lb)
Weight (group)	86.44 kg (190.5 lb)
Dimensions	314.9 x 127 mm (12.39 x 5 in)

Part Number	Description
376-4554	Truck Body Lifting Pin
376-4556	Truck Body Lifting Pin

260-9412 Lift Chain Assembly

Model: Track-Type Machines

Warranty: Six Months



European Union compliant, CE marked

- Used to remove, install, and position track segments on track-type machines
- Used with suitable overhead lifting device
- Clamping shoes provide a quick, secure method of attaching to track segments
- Large master link joins two lengths of Grade 80 chain and provides attachment point for lifting device
- Versatile design fits a wide range of track segments with various widths

Reference

NEHS1077, Tool Operating Manual, 260-9412 Lift Chain

Working load limit	454 kg (1,000 lb)
Approximate length	922.5 mm (36.0 in) ¹
Weight	5.9 kg (13 lb)
Master link	65.3 mm (2.57 in) wide opening with 12.7 mm (.50 in) diameter steel
Clamping shoe	maximum jaw opening - 25.4 mm (1.0 in) jaw depth - 90 mm (3.6 in)
¹ Varies with chain angle (spread).	

Part Number	Description
260-9412	Lift Chain Assembly

207-0755 Lifting Plate, 207-0756 Lift Chain Assembly

Model Usage: D6R, D6T

Warranty: Six Months



European Union Compliant, CE marked

- Used to safely remove and install C9 engines from machine
- Connects correctly and easily to engine and lifting device
- Use 207-0756 with 142-6893 adjustable C-hook and 207-0755 Lifter Plate

Reference

NEHS1094, Tool Operating Manual

REN8175, D6R Series III and D6T Track-Type Tractors Engine Supplement

REN4253, D6R Series II Track-Type Tractor C9 Engine Supplement

KENR8563, D6R Track-Type Track Engine Supplement

Specifications		
	207-0755	207-0756
Working Load Limit	1588 kg (3500 lb)	5443 kg (12,000 lb)
Material	Durable Steel	Grade 800 Steel Chain

Part Number	Description
207-0755	Lifting Plate
207-0756	Lift Chain Assembly
Serviceable Part(s)	
1U-9793	Hook

328-1720 Tube Assembly, 329-1968 Adapter

Essential Tool

Model: SR4, SR5, and C175-16 Generators

Warranty: Six Months

- Used to remove and install rotor assembly with generator in horizontal position
- Length of 328-1720 Tube Assembly (2083 mm [82 in]) provides leverage to float rotor assembly in or out of generator
- 328-1720 Tube Assembly has brass adapter that directly fits SR4 and SR5 generator rotor shaft
- 4 set screws on 328-1720 Tube Assembly lock tool onto SR4 and SR5 rotor shaft or 329-1968 Adapter
- Brass adapter must be removed from 328-1720 Tube Assembly for use with 329-1968 Adapter and C175-16 generator rotor shaft

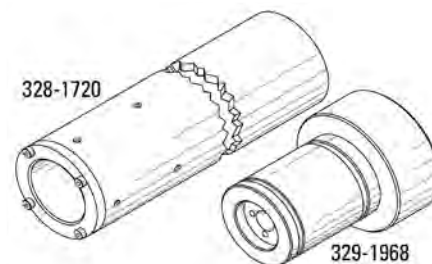

Part Number	Description
328-1720	Tube Assembly
329-1968	Adapter
Service/Repair Parts	
9F-6641	Bolt

330-9910 Adapter

Essential Tool

Model: C175 1800 Frame Generators

Warranty: Six Months

- Used to remove and install rotor assembly with generator in horizontal position
- Used with 328-1720 Tube Assembly (sold separately)
- Four bolts and brass adapter must be removed from 328-1720 Tube Assembly before attaching 330-9910 Adapter
- 330-9910 Adapter is inserted into 328-1720 Tube Assembly
- Four set screws on 328-1720 engage grooves in 330-9910 Adapter to lock it in position



Part Number	Description
330-9910	Adapter

420-5317 Crib Tool

421-6081 Wedge

Model Usage: All

Warranty: Six Months

- 420-5317 used to build super solid stable box crib
- 421-6081 used to fill gaps between the load and cribbing
- Includes stepped top surfaces, sloped downward for extra gripping power
- Dual surface for cribbing (Pyramid surface and Lincoln log surfaces)
- Stronger, cleaner and safer than wood
- No-splitting, recycled materials
- Equipped with handling ropes
- Colored black

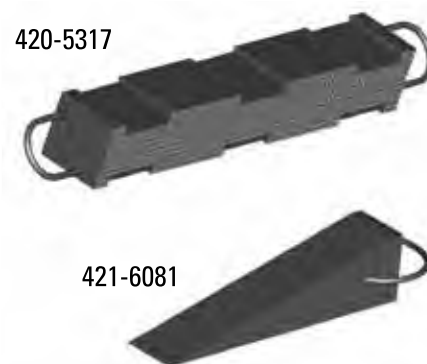

Lifting/Blocking/Clamping

(Continued)

420-5317 Crib Tool (Continued)

421-6081 Wedge

Model Usage: All

Warranty: Six Months

Specifications		
Part Number	Dimensions	Weight
420-5317	152.4 x 152.4 x 914.4 mm (6 x 6 x 36 in*)	17.24 kg (38 lb)
421-6081	152.4 x 203.2 x 609.6 mm (6 x 8 x 24 in*)	12.25 kg (27 lb)
* Lumber sizes		

Lifting Eyebolt Assembly

Model Usage: All

Warranty: Six Months



European Union Compliant, CE marked

- Used to lift basic components using threaded holes
- Star Shaped
- WLL clearly identified in Metric Tonnes and pounds
- WLL is de-rated at a 90 degree pull
- Eyebolt is adjustable 360 degrees
- Locking device allows for tightening by hand
- Powder Coating permanently changes color to beige to brown to black, if excessive heat is applied - Do not use, if powder coating is beige, brown, or black.
- Surface Pink Powder Coating

Part Number	Thread Size	Working Load		Weight
		Vertical	At 90 Degree	
395-1099	3/8 - 16 UNC	1000 kg (2205 lbs)	400 kg (882 lbs)	.12 kg (0.26 lb)
395-1094	1/2 - 13 UNC	2000 kg (4409 lbs)	750 kg (1653 lbs)	.22 kg (0.48 lb)
395-1100	5/8 - 11 UNC	4000 kg (8818 lbs)	1500 kg (3307 lbs)	.33 kg (0.73 lb)
395-1098	3/4 - 10 UNC	6000 kg (13228 lbs)	2300 kg (5071 lbs)	.54 kg (1.19 lb)
395-1101	7/8 - 9 UNC	6000 kg (13228 lbs)	2300 kg (5071 lbs)	.64 kg (1.41 lb)
395-1096	1 - 8 UNC	8000 kg (17637 lbs)	3200 kg (7055 lbs)	.98 kg (2.16 lb)
421-5660	M8	--	--	0.12 kg (0.26 lbs)
395-1093	1 1/4 - 7 UNC	12000 kg (26455 lbs)	4500 kg (9921 lbs)	1.82 kg (4.01 lb)
395-1092	1 1/2 - 6 UNC	16000 kg (35274 lbs)	7000 kg (15432 lbs)	3.60 kg (7.94 lb)
395-1095	1 3/4 - 5 UNC	24000 kg (52911 lbs)	9000 kg (19842 lbs)	4.95 kg (10.91 lb)
395-1097	2 - 4.5 UNC	32000 kg (70548 lbs)	12000 kg (26455 lbs)	7.60 kg (16.75 lb)

Lifting Eyebolt Assembly

Part Number	Size	Working Load		Weight
		Vertical	at 90 Degree	
421-5660	M8	1000 kg (2205 lbs)	400 kg (882 lbs)	0.12 kg (0.26 lbs)
421-5661	M10	1000 kg (2205 lbs)	400 kg (882 lbs)	0.12 kg (0.26 lbs)
421-5662	M12	2000 kg (4409 lbs)	750 kg (1653 lbs)	0.20 kg (0.44 lbs)
421-5663	M16	4000 kg (8818 lbs)	1500 kg (3307 lbs)	0.30 kg (0.66 lbs)
421-5664	M18	4000 kg (8818 lbs)	1500 kg (3307 lbs)	0.30 kg (0.66 lbs)
369-5916	M20	6000 kg (13228 lbs)	2300 kg (5071 lbs)	0.50 kg (1.10 lbs)
421-5665	M24	8000 kg (17637 lbs)	3200 kg (7055 lbs)	0.80 kg (1.76 lbs)
421-5666	M30	12000 kg (26455 lbs)	4500 kg (9921 lbs)	1.60 kg (3.53 lbs)
421-5667	M36	16000 kg (35274 lbs)	7000 kg (15432 lbs)	3.50 kg (7.72 lbs)
421-5668	M42	24000 kg (52911 lbs)	9000 kg (19842 lbs)	4.90 kg (10.80 lbs)
421-5669	M48	32000 kg (70548 lbs)	12000 kg (26455 lbs)	7.00 kg (15.43 lbs)



Load Ring Assemblies

Model Usage: All

Warranty: Six Months

European Union Compliant, CE marked

- Used to lift basic components using threaded holes
- Load Ring will rotate 360°
- WLL clearly identified in Metric Tonnes
- Adjustable in pull direction
- Load ring foldable
- Powder Coating permanently changes color to beige to brown to black, if excessive heat is applied - Do not use, if powder coating is beige, brown, or black.
- Surface Pink Powder Coated

Part Number	Thread Size	Working Load	Weight
395-1590	1/2 - 13 UNC	1000 kg (2204.6 lb)	.33 kg (0.73 lb)
395-1591	5/8 - 11 UNC	1500 kg (3306.9 lb)	.55 kg (1.21 lb)
395-1592	3/4 - 10 UNC	2500 kg (5511.6 lb)	1.3 kg (2.87 lb)
395-1593	7/8 - 9 UNC	2500 kg (5511.6 lb)	1.3 kg (2.87 lb)
395-1594	1 - 8 UNC	4000 kg (8818.5 lb)	1.5 kg (3.31 lb)
395-1595	1 1/4 - 8 UNC	5000 kg (11023.0 lb)	3.33 kg (7.34 lb)



Load Ring Assemblies



Part Number	Size	Working Load		Weight
		Vertical	at 90 Degree	
422-5471	M8	300 kg (661 lbs)	300 kg (661 lbs)	0.30 kg (0.66 lbs)
422-1780	M8 ¹	300 kg (661 lbs)	300 kg (661 lbs)	0.10 kg (0.22 lbs)
422-5472	M10	630 kg (1389 lbs)	630 kg (1389 lbs)	0.32 kg (0.71 lbs)
422-1781	M10 ¹	630 kg (1389 lbs)	630 kg (1389 lbs)	0.10 kg (0.22 lbs)
422-5473	M12	1000 kg (2205 lbs)	1000 kg (2205 lbs)	0.33 kg (0.73 lbs)
422-1782	M12 ¹	1000 kg (2205 lbs)	1000 kg (2205 lbs)	0.10 kg (0.22 lbs)
422-5474	M16	1500 kg (3307 lbs)	1500 kg (3307 lbs)	0.55 kg (1.21 lbs)
422-1783	M16 ¹	1500 kg (3307 lbs)	1500 kg (3307 lbs)	0.10 kg (0.22 lbs)
422-5475	M20	2500 kg (5291 lbs)	2500 kg (5291 lbs)	1.30 kg (2.87 lbs)
422-1784	M20 ¹	2500 kg (5291 lbs)	2500 kg (5291 lbs)	0.10 kg (0.22 lbs)
422-5476	M24	4000 kg (8818 lbs)	4000 kg (8818 lbs)	1.50 kg (3.31 lbs)
422-1785	M24 ¹	4000 kg (8818 lbs)	4000 kg (8818 lbs)	0.10 kg (0.22 lbs)
422-5477	M30	5000 kg (11023 lbs)	5000 kg (11023 lbs)	3.30 kg (1.76 lbs)

¹ Max Bolt Length plus washer and nut. Clearance hole applications.

385-1152 Rear Suspension Lifting Device

Model Usage: 793 OHT's

Warranty: Six Months

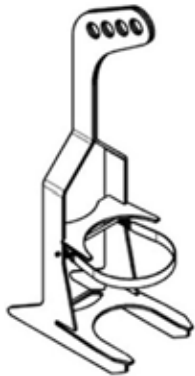

European Union Compliant, CE marked

- Used to safely remove and install the rear suspension cylinders on the OHT's
- Includes ratchet strap that securely fasten rear suspension cylinder to tool

Reference

NEHS1147 Tool Operating Manual

Specifications	
Dimensions	1875.47 x 768.9 x 460 mm (73.8 x 30.3 x 18.1 in)
Weight	88.9 kg (196 lb)
Working Load Limit	907.2 kg (2000 lb)