

Major Equipment

Notice	8-3
Hydraulic Cylinder Service	8-4
Hydraulic Test Centers	8-15
Automatic Welding	8-25
Boring Bar.....	8-28
Auxiliary Power Supply	8-31
Uninterruptible Power Supply	8-32
Gas Cutting/Welding Equipment.....	8-40
Service Truck Bodies.....	8-45

Notice**Notice**

When purchasing new Capital Tooling, please contact your Dealers Service Tools representative first. There will be tools available for order that previously required a quote. This contact will ensure that you order the proper tooling needed for your area and avoids potential order cancellation after 24 hours. Please include your dealer contact name, phone number and email address.

Contact Information**Eastern United States & Americas South**

501 S.W. Jefferson Ave.

Peoria, IL 61630-2125

E-mail: Curry_Jeffory_T@cat.com

EAME & Canada

Kevin Eccles

501 S.W. Jefferson Ave.

Peoria, IL 61630-2125

E-mail: Eccles_Kevin_D@cat.com

APD & Western United States

Allan Teuerle

501 S.W. Jefferson Ave.

Peoria, IL 61630-2125

E-mail: Teuerle_Allan_R@cat.com

Hydraulic Cylinder Service

Hydraulic Cylinder Repair Stands - 40.8 and 54.4 kN·m (30,000 and 40,000 ft·lb) Torque

Model: Cat® Hydraulic Cylinders

Warranty: Six Months

European Union compliant, CE marked

- All machines require 3-phase power supply; customer must specify 50 Hz or 60 Hz and required voltage when ordering.
- Used to remove and install threaded barrel caps and piston retaining nuts of hydraulic cylinders being overhauled
- Repair stand is operated from 1 side (saves valuable floor space by installing unit next to wall)
- Hydraulic nut runner, conical mounting bushings (small and medium included), double acting torque head, indexing cylinder
- Adjustable tailstock for various cylinder lengths
- Fast and powerful rod extension and retraction
- Conical rod eye adapters make cylinder installation, with various rod eye diameters, much faster and easier (no need to search for just the right size adapter)
- Heavy-duty pendant control provides on/off, torque/detorque, screw/unscrew, and extend/retract functions at operators finger tips (pendant uses a 8 m [25 ft] cable for operator convenience and safety)
- Designed to use a waste barrel to capture hydraulic fluid during overhaul procedures
- Adjustable support stand provides vertical, horizontal, and diagonal adjustment to prevent seal damage during assembly due to misalignment
- Eye-level torque gauge gives operator applied torque and break-away torque readings (assures factory torque specifications are met during assembly)
- Unit is completely wired and ready for installation (comes complete with mounting hardware and installation instructions)
- Hydraulic power supply and hoses
- Handheld, pendant-mounted controls
- Headstock chuck wing, which supports the cylinder eye, and the tailstock chuck wing, which supports the rod eye, are standard size
- Small and medium sets of conical bushings
- Universal high torque wrench handles piston nuts from 50.8 to 127 mm (2 to 5 in)
- Universal spanner wrench loosens the threaded glands or crown heads
- Rod support uses a wooden cradle to protect the chromium-plated rod and includes horizontal and vertical adjustments
- Cylinder barrel support includes both horizontal and vertical adjustments
- Portable oil basin and dolly collects oil from the cylinder during the honing process
- Mounting hardware
- Manual valve package switches between the torque cylinder and the nut runner without disconnecting and reconnecting the hydraulic hoses
- Low torque monitor displays the break away and the applied torque below 415 kg m (3000 lb ft) while the high torque monitor displays the applied torque above 415 kg m (3000 lb ft)

Reference

NEDG6005

Cylinder extension	244 cm (8.0 ft) in less than 1 minute
Head nut runner capacity	5440 N·m (4000 ft·lb)
Head nut runner speed	6 RPM
Indexing cylinder travel	122 cm (4.0 ft)
Small and medium size conical adapters	25 mm (1.0 in) - 146 mm (5.75 in) diameters
Large size conical adapter (optional)	152 mm (6.0 in) - 203 mm (8.0 in) diameters
Electric motor	5 Hp
Hydraulic tank capacity	38 L (10 gal)

(Continued)

Hydraulic Cylinder Repair Stands - 40.8 and 54.4 kN-m (30,000 and 40,000 ft-lb) Torque (Continued)

Model: Cat® Hydraulic Cylinders

Warranty: Six Months



Part Number	Description	Torque Capacity	Extended Cylinder Length Capacity	Cylinder Diameter Capacity
152-4249	HCS-30 CE	30,000 ft-lb (40.7 kN-m)	30 cm (1.0 ft) - 5.9 m (19.4 ft)	380 mm (15 in)
152-4251	HCS-40 CE	40,000 ft-lb (54.2 kN-m)	30 cm (1.0 ft) - 7.9 m (26.0 ft)	560 mm (22 in)
Adapters for Spline Drive Sockets				
4C-4296	Ball Joint Chuck Adapter	--	--	--
4C-4299	Blank Chuck Adapter	--	--	--
4C-4301	V Block Chuck Wings	--	--	--
4C-4305	Square Drive Adapter	--	--	--
4C-4306	Square Drive Adapter	--	--	--
4C-4307	Square Drive Adapter	--	--	--
4C-4308	Square Drive Adapter	--	--	--
4C-8092	Extra Large Adjustable Torque Wrench	--	--	--
4C-9309	Spanner Pin Group	--	--	--
263-9036	Adapter, Spline 30 and 40	--	--	--
263-9037	Pan Kit, Telescopic Drip ¹	--	--	--
263-9038	Crown Wrench Group	--	--	--
263-9039	Wing Group, Offset Chuck	--	--	--
263-9040	Wing Group - D11 Chuck	--	--	--
263-9041	Adapter - D11	--	--	--
263-9042	Bushing Kit, Larger Conical	--	--	--

¹ Made for the 30, but will work on the 40 with a 3 foot gap at the end

Hydraulic Cylinder Repair Stands - 60,000 ft-lb (81.6 kN-m) Torque

Model: Cat® Hydraulic Cylinders

Warranty: Six Months

European Union compliant, CE marked (152-4252)

- Small and medium conical bushing set
- Large conical bushing kit
- Hydraulic power supply and hoses
- Handheld, pendant-mounted controls
- Headstock chuck wing, which supports the cylinder eye, and the tailstock chuck wing, which supports the rod eye, are standard size
- Universal high torque wrench handles piston nuts from 50.8 to 127 mm (2 to 5 in)
- Universal spanner wrench loosens the threaded glands or crown heads
- Rod support uses a wooden cradle to protect the chromium-plated rod and includes horizontal and vertical adjustments
- Cylinder barrel support includes both horizontal and vertical adjustments
- Portable oil basin and dolly collects oil from the cylinder during the honing process
- Mounting hardware
- Manual valve package switches between the torque cylinder and the nut runner without disconnecting and reconnecting the hydraulic hoses
- Low torque monitor displays the break away and the applied torque below 415 kg m (3000 lb ft) while the high torque monitor displays the applied torque above 415 kg m (3000 lb ft)
- All machines require 3-phase power supply; customer must specify 50 Hz or 60 Hz and required voltage when ordering.
- Used to remove and install threaded or bolt-on barrel caps and piston retaining nuts of hydraulic cylinders being overhauled
- Unit includes universal spanner and high-torque wrench (eliminates buying expensive conventional sockets)
- Repair stand is operated from one side (saves valuable floor space by installing unit next to wall)
- Hydraulic workstation moves automatically between work position and park position (also has gauge that reads and records applied torque)
- Conical mounting bushings, double acting torque head, indexing cylinder
- Adjustable tailstock for various cylinder lengths
- Fast and powerful rod extension and retraction
- Conical rod eye adapters make cylinder installation, with various rod eye diameters, much faster and easier (no need to search for just the right size adapter)
- Heavy-duty pendant control provides on/off, torque/detorque, screw/unscrew, and extend/retract functions at operators finger tips (pendant uses a 8 m (25 ft) cable for operator convenience and safety)
- Eye-level torque gauge gives operator applied torque and break-away torque readings (assures that factory torque specifications are met during assembly)
- Unit is completely wired and ready for installation (comes complete with mounting hardware and installation instructions)

Reference

NEDG6005

Head nut runner capacity	5440 N-m (4000 ft-lb)
Head nut runner speed	6 RPM
Indexing cylinder travel	122 cm (4.0 ft)
Conical adapters	38 mm (1.5 in) to 203 mm (8.0 in) diameters
Electric motor	7.5 Hp
Hydraulic tank capacity	19 L (5 gal)

(Continued)

Hydraulic Cylinder Repair Stands - 60,000 ft-lb (81.6 kN-m) Torque (Continued)

Model: Cat® Hydraulic Cylinders

Warranty: Six Months

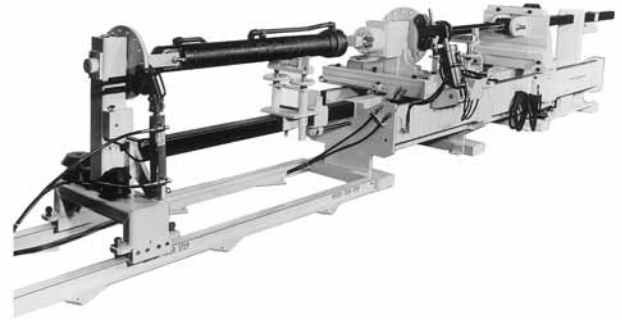

Part Number	Description	Torque Capacity	Extended Cylinder Length Capacity	Cylinder Diameter Capacity
152-4252	HCS-60 CE	60,000 ft-lb (81.6 kN-m)	7.3 m (24 ft)	508 mm / 762 mm (20.0 in / 30.0 in)
152-4255	HCS-60-L CE	60,000 ft-lb (81.6 kN-m)	10.4 m (34 ft)	508 mm / 762 mm (20.0 in / 30.0 in)
Adapters for Spline Drive Sockets				
4C-4305	Square Drive Adapter	--	--	--
4C-4306	Square Drive Adapter	--	--	--
4C-4307	Square Drive Adapter	--	--	--
4C-4308	Square Drive Adapter	--	--	--
4C-4297	Ball Joint Chuck Adapter	--	--	--
4C-4300	Blank Chuck Adapter	--	--	--
4C-4309	Spanner Pin Group	--	--	--
4C-4301	V Block Chuck Wings	--	--	--
4C-8092	Extra Large Adjustable Torque Wrench	--	--	--
263-9038	Crown Wrench Group	--	--	--
263-9039	Wing Group, Offset Chuck	--	--	--
263-9040	Wing Group - D11 Chuck	--	--	--
263-9041	Adapter - D11	--	--	--
263-9043	Adapter, Deep Socket	--	--	--
263-9044	Insert, 5 in hex	--	--	--
263-9045	Insert, 5.5 in hex	--	--	--
263-9046	Insert, 6 in hex	--	--	--
263-9047	Insert, 6.5 in hex	--	--	--
263-9048	Insert, 7 in hex	--	--	--
263-9049	Insert, 7.5 in hex	--	--	--
263-9050	Insert, 8 in hex	--	--	--
263-9051	Insert, 8.6 in hex	--	--	--
263-9052	Insert, 130 mm square	--	--	--

(Continued)

Hydraulic Cylinder Repair Stands - 60,000 ft-lb (81.6 kN-m) Torque (Continued)

Model: Cat® Hydraulic Cylinders

Warranty: Six Months

Part Number	Description	Torque Capacity	Extended Cylinder Length Capacity	Cylinder Diameter Capacity
Adapters for Spline Drive Sockets (Continued)				
263-9053	Insert, 130 mm hex	--	--	--
263-9054	Insert, 135 mm hex	--	--	--
263-9055	Insert, 145 mm hex	--	--	--
263-9056	Insert, 145 mm square	--	--	--
263-9057	Insert, 155 mm square	--	--	--
263-9058	Insert, 170 mm hex	--	--	--
263-9059	Adapter, Spline 60	--	--	--

Manual Hone Components

Model: Hydraulic Cylinders

Warranty: Six Months

- Manual hone components need to be ordered separately.

Manual Hone

- Less expensive alternative when reconditioning cylinders (no longer necessary to send cylinders to outside suppliers)
- Unit works best in low production shops
- Honing ensures a quality, long-lasting repair by renewing the bore surface and removing irregularities or other cylinder damage
- Capable of honing 3.6 m (12 ft) long cylinders with diameters ranging from 63.5 to 406 mm (2.50 to 16 in)
- Power for hone is supplied by a 4-speed electric drill
- A drill coupler absorbs forward and reverse thrust, removing direct force from drill gears and making drills last longer by reducing wear
- Used with a specially formulated honing oil
- Can be upgraded to an automatic hone as production demands increase

Reference

SEHS9538, Tool Operating Manual, Manual Hone Group



Manual Hone Group

Manual Hone Components (Continued)

Model: Hydraulic Cylinders

Warranty: Six Months

Part Number	Description	Electrical Requirements	Size
Manual Hone (order for a complete unit)			
9U-6477	Barrel Cradle Stand Group	--	--
9U-6759	Drain Tank and Pump ¹	110 V, 60 Hz, single-phase	--
1U-9031	Drain Tank and Pump	220 V, 50/60 Hz, single-phase	--
9U-5797	Drill ²	110 V, 60 Hz, single-phase	--
9U-5888	Drill	220 V, 50/60 Hz, single-phase	--
9U-6476	Drill Support Stand Group	--	--
9U-6463	Hone Group	--	--
245-4787	Thrust Coupler	--	--
Service/Repair Parts for Manual or Semi-Automatic Hone			
9U-6748	Dressing Stick	--	--
9U-6481	Finish Stone Set	--	89 - 140 mm (3.5 - 5.5 in)
9U-6478	Finish Stone Set	--	119 - 381 mm (4.7 - 15.0 in)
6V-7865	Finish Stone Set	--	68 - 104 mm (2.7 - 4.1 in)
6V-7866	Finish Stone Set	--	63 - 68 mm (2.5 - 2.7 in)
9U-6484	Honing Oil	--	--
9U-6749	Master Holder Set	--	203 - 304 mm (8.0 - 12.0 in)
9U-6746	Rough Stone Set	--	63 - 68 mm (2.5 - 2.7 in)
9U-6480	Rough Stone Set	--	89 - 140 mm (3.5 - 5.5 in)
9U-6479	Rough Stone Set	--	119 - 381 mm (4.7 - 15.0 in)
9U-6483	Rough Stone Set	--	68 - 104 mm (2.7 - 4.1 in)

¹ Can use Drain Tank and Pump part number 9U-6759 or 1U-9031

² Can use Drill part number 9U-5797 or 9U-5888

HTA4100 Sunnen Hone

Model: Hydraulic Cylinders

Warranty: Six Months

- Used to recondition hydraulic cylinders, ideal for resurfacing and repair work where light-duty stock removal up to 0.76 mm (.030 in) is needed to oversize deeply scored actuator bores
- Equipped with electromechanical stroker and a powerful 2,24 kW (3 Hp) spindle unit
- An all-electric machine with no hydraulics means less noise, no leaks, better control, and more accuracy during bore reversals
- Quiet and precise operation is achieved using a servo motor with belt drive
- An auto tensioning system has a programmable tool feed or manual feed is available when needed
- A separate coolant filtration unit (coolant cart) is mounted on casters for mobility and neatly stores under the main frame
- Modular workpiece support allows cylinders weighing up to 3630 kg (8000 lb) to be reconditioned
- A flexible, modular work-holding system allows rapid setups of a wide variety of workpieces, 2 fixtures standard
- All machine features are controlled through a touchscreen PLC controlled operator station, meaning no hydraulic valves to adjust or limit switches to move
- Operator station swivels for ease of setup and operation
- A joystick control enables operator to easily move honing tool over entire stroke length to set ends of stroke



(Continued)

HTA4100 Sunnen Hone (Continued)

Model: Hydraulic Cylinders

Warranty: Six Months

- Load meter indicates location of tight spots within cylinder bore
- Stroke control override allows short stroking in any part of bore to clean up tight spots
- Easy-to-remove standard guards (not CE compliant) — guards cover each end of cylinder to control coolant splash
- Optional work holding configurations, CE guarding, and transformer configurations to accommodate voltage/frequency combinations beyond 400 VAC 50 Hz / 460 VAC 60 Hz
- Longer machines available in 6/8/10 meter stroke lengths

Repair Information

Sunnen Products Company

World Headquarters

St Louis, MO - USA

Phone: (314) 781-2100

Fax: (314) 781-2268

Email: sunnen@sunnen.com

Web site: www.sunnen.com

For additional information, please contact your Dealer Service Tools Representative or visit the Key Supplier Relationship section on the Dealer Service Tools website.

HTA4100 Specifications	
Spindle speed	20 - 300 RPM
Spindle power	2.24 kW (3 Hp)
Stroke power	1.12 kW (1.5 Hp)
Stroke range	Up to 4 m (13.12 ft)
Stroke speed range	1.52 to 2.74 m/minute (5 to 90 ft/minute)
Bore diameter range ¹	64 to 533 mm (2.5 to 21 inches)
Stock removal rate (approximate) ²	131 cubic cm/hr (8 cubic in/hour)
Electrical power supply ³	400/460 Volt, 50/60 Hz, 3 phase, 15 amp
Weight (including coolant cart)	1815 kg (4000 lb)
HTA4100 Coolant Cart Specifications	
Coolant capacity	208 L (55 gal)
Filtration	Paper bed filter media
Hose connections	Quick disconnect
Mobility	Four heavy-duty casters
Coolant level	Sight glass
Power	Centrifugal pump
Flow	55 Lpm (15 gpm)
¹ For diameter sizes below 64 mm (2.5 in) contact the Sunnen representative.	
² Actual stock removal rates will vary, depending on application.	
³ Optional transformer configurations also available.	

Serviceable Parts

Part Number	Description	Material	Dimensions
417-6954	Filter Paper Roll	Purfio "O" material for oil application flat bond, spunbond polyester 40-45 micron filtration	698.5 mm (27.5 in) wide, 91.44 meters (100 yd) long; 76.2 mm (3 in) I.D., 165.1 mm (6.5 in) long

250-6597 Cylinder Washer Tank Group

Model: Hydraulic Cylinders

Warranty: Six Months

European Union compliant, CE marked

- Replaces canceled 120-9143 and 232-4686 Cylinder Washer Tank Groups
- Used to clean honing oil and metal particles from inside of reconditioned cylinders (provides quick and efficient cleaning method)
- Operates completely by air pressure (no electricity)
- Cleans cylinders ranging from 101 to 343 mm (4.0 to 13.5 in) diameter and 1.8 to 3.6 m (5.9 to 11.8 ft) in length (attachment sold separately)
- Unit can be positioned at end of manual or automatic hone group (allows cylinders to remain clamped in hone group during cleaning procedure)
- Washer uses an air powered drill (sold separately) to rotate cleaning brushes (sold separately) while a pump supplies cleaning solvent to brush head
- Uses disposable filter bags to capture contaminants (keeps fluid clean and makes cleanup and disposal easier)
- Uses a 3 process to filter cleaning solution
 1. 2 magnet assemblies catch large ferrous materials
 2. Dual filter bags capture particles 25 microns and larger
 3. Final synthetic, spin on filter cleans fluid before it is pumped to cleaning brush assembly

Reference

NEHS0927-02, Tool Operating Manual, Procedures for Using the 250-6597 Cylinder Washer Tank Group

Cylinder Cleaning and Storage

When cleaning a hydraulic cylinder — especially important after honing — the primary objective is to remove harmful contaminants. Testing has shown that this is best accomplished by the scrubbing action of rotating brushes, used with a cleaning solution that flushes the contamination out of the cylinder. Caterpillar® offers a cylinder washer, tooling, and a water-based cleaning chemical that is very effective in cleaning honed cylinders.

After the cylinder is clean, it is important to keep rust from forming on the bare metal surface of the bore. The recommended Cat® cleaning chemical provides mild rust protection. However, if the cylinder will not be assembled into a group for an extended period of time, depending on the environment, oxidation of the smooth surface can be a problem.

Options to deal with this include arranging the process so that cylinders are assembled within a few days of being washed, or taking additional storage precautions with additional rust inhibitors that can provide longer term protection. Spraying the bore with a light, clean oil may be sufficient to extend the rust protection. Other stronger products could also be used. The amount of protection required depends on several factors such as storage time, ambient conditions, other packaging, etc. If a cylinder is to be sealed on the ends, it must be completely dry and in a dry environment.



(Continued)

250-6597 Cylinder Washer Tank Group (Continued)

Model: Hydraulic Cylinders

Warranty: Six Months

Part Number	Description	Detail	Quantity
250-6597	Cylinder Washer Tank Group	--	--
Additional Tooling (Sold Separately) for Complete Cylinder Tube Cleaning System			
171-5688	Pneumatic Drill ¹	--	1
120-9144	Rotating Valve Group	--	1
120-9146	Brush Assembly	Including Spray Nozzle	1
120-9148	Brush	76 mm (3.0 in), used for 100 - 190 mm (4.0 - 7.5 in) diameter cylinder bores	6
120-9147	Brush	152 mm (6.0 in), used for 190 - 343 mm (7.5 - 13.5 in) diameter cylinder bores	6
120-9154	Arbor Tube	1.8 m (6.0 ft)	1
120-9153	Arbor Tube	3 m (10.0 ft)	1
120-9152	Arbor Tube	3.6 m (12.0 ft)	1
135-7643	Nozzle Adapter	Optional	1
Service/Repair Parts			
184-2319	Filter Bag	25 micron	1
198-3188	Element, 2-micron	2 micron	1
9U-5870	Element - Filter, 10-Micron	10 micron	1
9U-6983	Filter Element, 5-Micron	5 micron	1

¹ Or equivalent

9U-6803 Cylinder Tester

188-3926 Cylinder Tester

Model: Hydraulic Cylinders

Warranty: Six Months



European Union compliant, CE marked (188-3926)

- Used to test hydraulic cylinders after reconditioning or repair (ensures that cylinders perform to correct specifications)
- Provides an efficient and simple method of testing cylinders
- Pressures can be regulated between 2,067 and 20,670 kPa (300 and 3,000 psi)
- Remote controlled, pressure-compensated pump provides fast cycling of cylinders
- Large hydraulic reservoir allows unit to test all Cat® and most other double-acting cylinders
- Control panel simplifies testing and gauges are large and easy to read
- After cylinder has been tested, oil is removed by using shop air pressure
- Unit is equipped with low-friction caster wheels
- Operates on 440 volt, 3-phase power (can be customer adapted to 220 volt, 3-phase)

Reference

NEHS0595, Tool Operating Manual, Cylinder Tester

Part Number	Description	Pump Capacity	Reservoir
188-3926	Cylinder Tester	80 lpm (21 gpm)	227 L (60 gal)
9U-6803	Cylinder Tester	80 lpm (21 gpm)	227 L (60 gal)

Flange Adapters

Model: All Models

Warranty: Six Months

- Used to aid mechanic in flow testing of various hydraulic systems — specifically used when flange-type XT3 and XT5 adapters are needed
- Straight, 45°, and 90° fittings available to orientate test hoses for easier accessibility to vehicles hydraulic components
- Longer length for faster/easier installation (allows use of conventional socket wrenches rather than flat wrenches used on former short adapters)
- Used with existing high pressure adapters and quick disconnects for flow testing on-vehicle or in shop
- Features 9/16-18 thread diagnostic “T” port for pressure testing operating systems

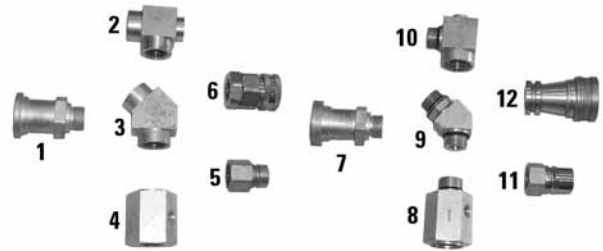

References

NEHT5000, Test Procedures

NEHT6000 through NEHT6045, Test Procedures

	Working pressure	Fitting end	Nominal size flange
XT3 Fittings	27,560 kPa (4,000 psi)	1 in NPT female thread	1/2 - 1 1/2 in
XT5 Fittings	41,340 kPa (6,000 psi)	1 5/16 in STOR male thread	3/4 - 1 1/2 in

Item	Part Number	Name	Detail
1	9U-7442	Adapter	1/2 in Flange Adapter
1	4J-5140	Seal	O-ring
1	1P-4574	Flange	1/2 in Split Flange
1	9U-7443	Adapter	3/4 in Flange Adapter
1	4J-5267	Seal	O-ring
1	1P-4576	Flange	3/4 in Split Flange
1	9U-7444	Adapter	1 in Flange Adapter
1	4J-0520	Seal	O-ring
1	1P-4577	Flange	1 in Split Flange
1	9U-7445	Adapter	1 1/4 in Flange Adapter
1	4J-0522	Seal (not shown)	O-ring
1	1P-4578	Flange	1 1/4 in Split Flange
1	9U-7446	Adapter	1 1/2 in Flange Adapter
1	4J-0524	Seal	O-ring
1	1P-4579	Flange	1 1/2 in Split Flange
1	7M-8485	O-ring Seal	O-ring for 16 Stor Threads
2	1U-8300	Fitting	1 in Pipe to 16 Stor Port-Straight
3	1U-8304	Fitting	1 in Pipe to 16 Stor Port-45°

Item	Part Number	Name	Detail
4	1U-8301	Fitting	1 in Pipe to 16 Stor Port-90°
5 ¹	8C-7544	Coupler	1 in NPT female non-valved QD
6 ²	8C-7545	Nipple	1 in NPT female non-valved QD (Not shown)
6	7X-7646	Nipple Assembly	1 in NPT female QD (Not shown)
7	9U-7438	Adapter	3/4 in Flange Adapter
7	1P-3702	Seal	O-ring
7	1P-5765	Flange	3/4 in Split Flange
7	9U-7439	Flange	1 in Flange Adapter
7	1P-3703	Seal, 38.66 mm (1.52 in) outside diameter	--
7	1P-5766	Flange	1 in Split Flange
7	9U-7440	Adapter	1 1/4 in Flange Adapter
7	1P-3704	Seal, 44.75 mm (1.76 in) outside diameter	--
7	1P-5767	Flange	1 1/4 in Split Flange
7	9U-7441	Adapter	1 1/2 in Flange Adapter
7	1P-3705	Seal	--

Major Equipment

(Continued)

Flange Adapters (Continued)

Model: All Models

Warranty: Six Months

Item	Part Number	Name	Detail
7	5P-8077	Flange	1 1/2 in Split Flange
8	1U-8302	Fitting	-16 Stor Port — 16 Stor Thread—Straight
9	1U-8305	Fitting	-16 Stor Port — 16 Stor Thread-45°

Item	Part Number	Name	Detail
10	1U-8303	Fitting	-16 Stor Port — 16 Stor Thread-90°
11	8C-9032	Nipple Assembly	-16 Stor non-valved QD

¹8C-7544 is Item 5 and 12

²8C-7545 is Item 6 and 12

1U-7608 Chain Wrench

Model: D6H, D7H and motor graders prior to April 1987 G-Series production

Warranty: Six Months



- Used to remove and install threaded crowns on hydraulic cylinders
- Can be used on threaded crowns up to 203.0 mm (8.0 in) in diameter
- Can be used with breaker bars, ratchets, and torque wrenches
- Grips cylindrical objects for assembly or disassembly
- Black oxide finish, high carbon steel
- 3/4 inch square drive
- Rated capacity: 1360 N-m (1000 ft-lb)
- Service part: 1U-7609 Standard Coupler

Head length	114.3 mm (4.50 in)
Head width	54.0 mm (2.13 in)
Head thickness	34.9 mm (1.38 in)
Chain length	711.2 mm (28.00 in)
Weight	0.86 kg (1.90 lb)

Part Number	Description
1U-7608	Chain Wrench

Hydraulic Test Centers

Large Hydraulic Test Centers

Model: Cat® Pumps, Motors and Transmissions

Warranty: Six Months

Available in 380/415/460/575 Volt, 50/60 Hertz, 3-Phase electrical, 200 to 400 Hp

- Complete test centers designed for testing and adjusting all Cat® pumps, motors, hydrostatic and powershift transmissions
- Unlike traditional test benches on the market that are primarily designed to test transmissions, it is designed for complete pump, motor, and hydrostatic transmission testing
- Cat® test centers are developed for greater performance but use traditional-sized components where possible to minimize costs
- Using digital electronic control output, drive speed can be maintained regardless of load
- Main manifold design allows for versatility in test configuration

Optional Features

- Multiple suction ports for testing tandem and triple pumps
- Additional signal pressure ports
- Extended external and internal filtration systems for gear pump testing (recommended for dealers who rebuild and test gear pumps frequently)
- Extended internal filtration systems for highly contaminated environments
- Additional sound attenuation
- Custom work support sump configurations
- Data acquisition system capable of monitoring and recording 9 flows, 14 pressures, 2 temperature channels as well as RPM and torque

Ordering Information

Each large hydraulic test center is built one at a time. This allows design of the system tailored to a specific machine population and component requirements.

Contact the Dealer Service Tools Division for quotations, specifications, and recommended tooling. The large test center is purchased outside of the Caterpillar® parts network via a purchase order.

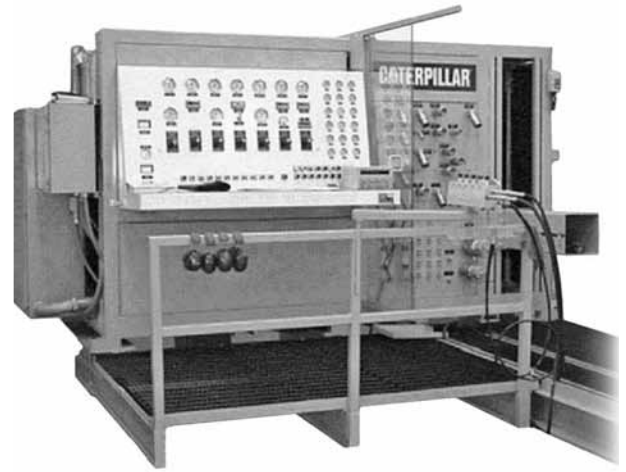

Hydraulic Test Centers

Large Hydraulic Test Centers Specifications

Reduced voltage motor starter	
Main oil tank capacity	1136 L (300 gal)
High capacity work support with integral sump	4,545 kg (10,000 lb)
Output shaft torque (at full motor displacement)	1,722 N·m (1,275 ft-lb)
RPM range	0 - 2550
Modes of operation	3:
Displacement (fully manual)	
Speed (maintains test speed during changing loads)	
Motor test (loaded rotating motor testing)	
Auxiliary pump	
215 lpm (0 - 57 gpm) electric displacement control	
0 - 41,340 kPa (0 - 6,000 psi)	
High pressure signal port (1)	0 - 51,680 kPa (0 - 7,500 psi)
Low pressure signal port (1)	0 - 4,134 kPa (0 - 600 psi)
Tank return ports	2
Regeneration/closed loop flow log	1
Main pump diagnostic ports	2
Supercharge in/out ports	2
Flowmeter loops	6:
19 - 795 lpm (5 - 210 gpm) loadable	
19 - 795 lpm (5 - 210 gpm) non-loadable	
11 - 322 lpm (3 - 85 gpm) loadable	
11 - 322 lpm (3 - 85 gpm) non-loadable	
4 - 8 lpm (1 - 2 gpm) low pressure. case drain	
2 - 19 lpm (0.5 - 5 gpm) low pressure case drain	
100 mm (4 in) gravity supply	1
Test ports connected to panel gauges	16
Internal 3-micron, high-capacity kidney loop filtration system	
12 kW thermostat-controlled tank heater	
Separate internal heat exchanger for closed loop hydrostatic pump testing	

Small Hydraulic Test Benches

Model: All Models

Warranty: Six Months

Available in 230/380/415/460/575 Volt, 50/60 Hertz, 3-Phase electrical, 125 or 150 Hp

- Used to test hydraulic pumps, motors, cylinders, and transmissions (including some hydrostatic)
- Designed as an economical option for testing current and future components within the 125 or 150 Hp range limit
- A "mini" bench having many of the same features as a larger hydraulic test center including elevated component oil tank, full instrumentation, full filtration (down to 5-micron) with control panel indicator lights, 2 pressure oil supplies, and large, low-profile testing bed
- Additional features: 2 digital flow meters, connection for external flow meters, digital flow and temperature readouts, automatic heating and cooling of testing oil supply, automatic oil level control of work table sump, built-in protection circuits, and digital RPM readout
- Cat® test benches are direct competitive replacements for 100/125 Hp class test benches.

Ordering Information

Contact the Dealer Service Tools Division for quotations, specifications and recommended tooling. The small hydraulic test bench is purchased outside of the Caterpillar® parts network via a purchase order

Reduced voltage soft-start motor starter	
Horsepower	125 or 150
Maximum drive output	2600 RPM
Gravity feed oil supply (flooded suction)	102 mm (4.0 in) diameter
Adjustable hydraulic supply #1	189 lpm at 20,670 kPa (50.0 gpm at 3000 psi)
Adjustable hydraulic supply #2	19 lpm at 2756 kPa (5.0 gpm at 400 psi)
Two flow meters	484 lpm (125 gpm)
External flow meter connections pressure	Up to 46,850 kPa (6800 psi) with flow rates of 8 - 800 lpm (2 - 210 gpm)
Indicator lights for all filters	



Mounting and Drive Hardware for Hydraulic Pump and Motor Testing

Model: Cat® Pumps, Motors and Transmissions

Warranty: Six Months

- Used for hydraulic pump and motor testing
- Mounting plates used with 1U-9130 Mounting Stand
- Drive adapters work with any size 27 drive shaft, standard on Aidco, Wolff and Schroder benches; drive adapters also work with 1U-9359 Adapter and can be used with size 55 drive shaft on Cat® Hydraulic Test Center



(Continued)

Mounting and Drive Hardware for Hydraulic Pump and Motor Testing (Continued)

Model: Cat® Pumps, Motors and Transmissions

Warranty: Six Months

Part Number	Spline Data	Remarks
Adapter Assembly		
1U-9359	—	For large drive shaft
Pump and Motor Drive Adapters		
1U-9841	14T-10/20	--
1U-9837	11T-12/24	--
9U-5746	12T-20 DEG	JIS
1U-9835	13T-8/16	--
1U-9833	13T-16/32	--
1U-9834	14T-12/24	--
9U-5747	14T-20 DEG	JIS
131-6452	N30X2X30X14X9g	DIN5480 - 14T
9U-7519	15T-8/16	--
9U-5744	15T-12/24	--
4C-4088	15T-16/32	--
9U-7520	15T-10/20	--
9U-7063	16T-20 DEG	JIS
9U-5276	16T B30X27X30 DEG	DIN 5482 MDL 1.75
9U-7521	17T-8/16	--
131-6456	17T-10/20	--
1U-9394	17T-12/24	--
9U-5748	17T-20 DEG JIS	--

Part Number	Spline Data	Remarks
Pump and Motor Drive Adapters (Continued)		
246-1588	18T-8/16	--
9U-5275	N40X2X30X18X9g	DIN 5480 - 18T
1U-9842	19T-16/32	--
4C-4385	19T-24/48136-3648	20T-8/16
9U-5745	20T-12/24	--
9U-5230	20T-B40X36X30 DEG	DIN 5482 MDL 1.75
133-2329	21T-16/32	--
9U-5277	N45X2X30X21X9g	DIN 5480 - 21T
1U-6433	N50X2X30X24X9g	DIN 5480 - 24T
142-8576	N55X2X30X26X9g	DIN 5480 - 26T
128-0794	27T-16/32	SPL
131-8620	N60X2X30X28X9g	DIN 5480 - 28T
4C-4705	30T-16/32	--
4C-4703	32T-16/32	External Spline
1U-9843	7/8 SAE B	Keyed shaft
1U-9844	1 1/4 SAE B	Keyed shaft
1U-9845	1 3/4 SAE B	Keyed shaft
1U-9846	1 taper	Keyed shaft
1U-9847	1 1/16 taper	Keyed shaft
136-3602	1 3/4 taper	Keyed shaft
326-4012	W28X1.25X30X21X9h	DIN 5480 -21

Adapter Plates and Stand Assembly

Model: Most Cat® Models

Warranty: Six Months



- Adapter plates and stand assembly used to mount hydraulic pumps and motors for bench testing; eliminates use of clamps, chains, and turnbuckles to secure test component to test bench bed
- Adapter plates slide into 1U-9130 Stand Assembly, becoming integral part of stand and creating sturdy free-standing fixture
- 1U-9130 Stand Assembly can be used on any test bench bed with mounting rail centerline width of 95.25 cm (37.5 in) and minimum rail slot width of 19.05 mm (3/4 in)
- Tooling designed to accommodate any horsepower rated pump or motor that Caterpillar® has in current production
- Adapter plate assemblies hold pumps and motors that have SAE-style mounting flanges, and either 2- or 4-hole mountings
- Safe, quick way to mount pumps and motors having standard SAE A, B, C, D, E and F style mounting configurations

Part Number	SAE Flywheel Adapter Plates	Mounting Configuration	Pilot Diameter
9U-5750	51.12 cm (20.125 in)	SAE No. 1	--
1U-5738	44.78 cm (17.630 in)	SAE No. 2	--
4C-4622	40.96 cm (16.125 in)	SAE No. 3	--
4C-4623	36.20 cm (14.250 in)	SAE No. 4	--

(Continued)

Adapter Plates and Stand Assembly (Continued)

Model: Most Cat® Models

Warranty: Six Months

Part Number	SAE Flywheel Adapter Plates	Mounting Configuration	Pilot Diameter
Mounting Adapter Plates Used with 1U-9130 Mounting Stand			
1U-9126	--	SAE-A	84.15 mm (3.313 in)
1U-9127	--	SAE-B	10.36 cm (4.079 in)
1U-9128	--	SAE-C	12.86 cm (5.061 in)
1U-9129	--	SAE-D-E-F	18.05 cm (7.106 in)
4C-4702	--	--	19.10 cm (7.720 in)
131-8683	--	--	15.30 cm (6.024 in) and 26.20 cm (10.315 in)
128-0929	--	--	22.30 cm (8.780 in)
131-8477	--	--	19.50 cm (7.677 in) and 28.03 cm (11.033 in)
328-1483	--	--	113 mm (4.449 in)

1U-9832 Drive Shaft

Model: Most Cat® models

Warranty: Manufacturer's Six Months

- Universal Drive Shaft Size 27 (Aidco, Wolff, Schroder Standard Shaft)
- Also allows Caterpillar® large test bench owners to run smaller components with small drive shaft (requires 4C-4336 Adapter)



Reference

NEHT5000, Bench Testing Hydraulic Components — complete listing of general test bench tooling

Repair Information

Parrish Power Products Inc.
P.O. Box 955
Toledo, OH 43697-0955
Phone: (419) 729-1601

Part Number	Description
1U-9832	Drive Shaft

4C-4336 Drive Shaft Adapter

Model: Most Cat® Models

Warranty: Six Months

- Allows large hydraulic test center owners to install optional 1U-9832 Drive Shaft to drive hub on test center
- When bench testing small pumps and motors on large hydraulic test centers, a smaller drive shaft is required due to the mass of standard drive shaft; if any misalignment occurs during pump installation, large shaft could overwhelm small component splined shaft causing vibration and severely loading component shaft bearing; smaller, optional 1U-9832 Drive Shaft corrects this situation but 4C-4336 Adapter plate must be used to couple it with large hydraulic test center
- Plate adapts from SAE size 55 drive shaft configuration to SAE size 27 pattern

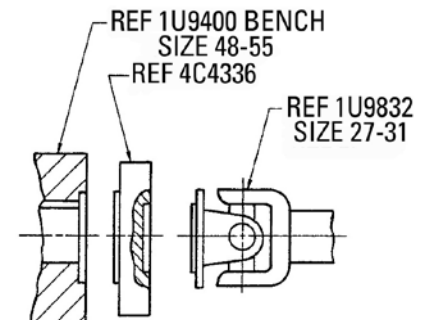

Part Number	Description
4C-4336	Drive Shaft Adapter

Motor Stall Adapters

Model: Most Cat® Models

Warranty: Six Months



- Used to stall test hydraulic fluid motors

Part Number	Spline
4C-4679	32T-16/32 External
4C-4680	19T-16/32 Internal

Bench Testing Hydraulic Components Fittings and Drive Connections

Model: Most Cat® Models

Warranty: Six Months

- General oil connection fittings used while testing hydraulic pumps, motors, and transmissions
- Used when testing variety of Cat® and competitive hydraulic components
- Good low to medium pressure base to support test bench needs



Item	Part Number	Description	Detail
Item 1: 2-Bolt Flanges (BHC = Bolt Hole Center)			
1	1U-9849	Flange	1/2 in Pipe x 1 7/8 in BHC
1	1U-9850	Flange	1 in Pipe x 2 1/2 in BHC
1	1U-9851	Flange	1 in Pipe x 1 in BHC
1	1U-9852	Flange	1 in Pipe x 2 1/2 in BHC
1	1U-9853	Flange	1 in Pipe x 2 5/8 in BHC
1	1U-9854	Flange	1 in Pipe x 2 3/4 in BHC
1	1U-9855	Flange	1 in Pipe x 2 7/8 in BHC
1	1U-9856	Flange	1 in Pipe x 3 in BHC
1	1U-9857	Flange	1 in 1/2 Pipe x 3 in BHC
1	1U-9858	Flange	1 in Pipe x 3 1/4 in BHC
1	1U-9859	Flange	1 in Pipe x 3 3/7 in BHC
1	1U-9860	Flange	1 in Pipe x 3 5/8 in BHC
1	1U-9861	Flange	2 in Pipe x 3 5/8 in BHC
1	1U-9862	Flange	1 in Pipe x 3 3/4 in BHC
1	1U-9863	Flang	2 in Pipe x 4 in BHC
1	1U-9864	Flange	1 in Pipe x 4 1/2 in BHC
1	1U-9865	Flange	2 1/2 in Pipe x 4 1/2 in BHC
Item 2: 4-Bolt Flanges			
2	1U-9866	Flange	3 in Pipe
2	1U-9867	Flange	3 1/2 in Pipe
2	1U-9868	Flange	4 in Pipe
2	1U-9869	Flange	1 1/4 in Pipe
2	1U-9870	Flange	1 1/2 in Pipe

(Continued)

Bench Testing Hydraulic Components Fittings and Drive Connections (Continued)

Model: Most Cat® Models

Warranty: Six Months

Item	Part Number	Description	Detail
Item 2: 4-Bolt Flanges (Continued)			
2	1U-9871	Flange	3/4 in Pipe
2	1U-9872	Flange	1 in Pipe
2	1U-9873	Flange	2 in Pipe
2	1U-9874	Flange	2 1/2 in Pipe
Item 3: Camstyle Fittings			
3	1U-9879	Adapter	3 in x 3 in FPT Adapter
3	1U-9880	Adapter	4 in x 4 in FPT Adapter
Item 4: Suction Hose and Fittings			
4	1U-9875	Coupler	3 in x 3 in Hose Barb
4	1U-9876	Coupler	4 in x 4 in Hose Barb
4	1U-9881	Hose	3 in ID x 12 ft (not shown)
4	1U-9882	Hose	4 in ID x 12 ft (not shown)
Item 5: Camstyle Fittings			
5	1U-9877	Adapter	3 in Coupler x 4 in NIP
5	1U-9878	Adapter	3 in NIP. x 4 in Coupler (not shown)

319-6497 Manifold Group

Model: Small and Large Test Benches

Warranty: Six Months

- Used to split pump suction into multiple sources
- Used with discontinued 1U-9400 and discontinued 9U-5000 Series Test Bench
- Necessary for tandem pump testing
- Designed to clamp onto rails of test bench
- Two camlok and three threaded ball-valve ports provide versatility
- Material: aluminum

Item	Description	Specification
1	Camlok Fitting with Cap	76.2 mm (3.0 in)
2	Camlok Fitting with Cap	101.6 mm (4.0 in)

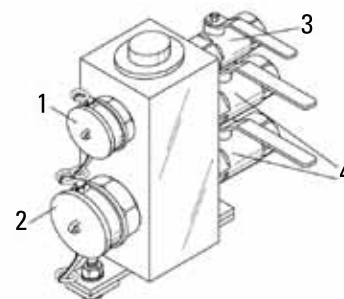

Item	Part Number	Description	Specification
—	319-6497	Manifold Group	—
Service/Repair Parts			
3	1C-4060	Lever Ball-Valve	1 1/2 in x 1 1/2 NPT(f)
4	133-6596	Lever Ball-Valve	2 in x 1 1/2 NPT(f)

4C-3582 Load Sensing Valve

Models: All Current Motor Graders; D4H, D5H, D6H, D7H and D8N Crawler Tractors; All Backhoe Loader implement circuits
Warranty: Six Months



4C-3582 shown with flow and pressure fittings installed

- Used in testing and adjusting high pressure cutout and margin pressures on load sensing pumps
- Compact, high pressure manifold containing flow control, relief valve, gauge and flow ports; flow control simulates control valve on vehicle; relief valve simulates load condition of implement circuit
- Flow capacity of test block is 227 lpm (60 gpm) with adjustable pressure range of approximately 345 to 41369 kPa (50 to 6000 psi)
- Margin pressure read by connecting 1U-5796 Differential Pressure Gauge to manifold gauge ports marked HI and LOW
- Sense line pressure taken from port marked "Sense Line" and should be connected to sense port on test pump compensator valve; test pump outlet flow is connected to "In" port and "Out" port oil is then routed through flowmeter; flow ports have been designed to accept 25.4 mm (1 in) SAE O-ring style fittings and will mate with Cat® XT-5 quick disconnect fittings mentioned in February 15, 1988 Service Magazine article
- Can be used in the field with 8T-0454 Flowmeter (Headland) or with hydraulic test bench; if used with test bench, only bench flowmeter should be used
- Cat® large hydraulic test centers have load sensing system incorporated in their hydraulics and do not require 4C-3582 valve

Reference

NEHT5000, Bench Testing Hydraulic Components (under procedures for testing load sensing pumps)

Part Number	Description
4C-3582	Load Sensing Valve

9U-5893 Heat Exchanger, 9U-5892 Relief Valve Cartridge, 9U-5902 Flow Straightener Block

Model: Challenger 65, 65B, and 75
Warranty: Six Months



- Used to test pump on any test bench
- Heat exchanger supplies cooled oil for easier and more accurate testing and adjusting (prevents overheating oil and burning pump)
- Flow straightener block eliminates improperly connected hoses and allows reversing pump direction without changing hoses
- A 1U-6392 Valve with 9U-5892 Relief Valve Cartridge eliminates need for external pressure supply for pump controls
- 9U-5892 Relief Valve Cartridge pressure: 0 to 3447 kPa (0 to 500 psi)

Reference

NEHT6041, Test Procedure

Part Number	Description
9U-5892	Relief Valve Cartridge
9U-5893	Heat Exchanger
9U-5902	Flow Straightener Block

1U-6392 Pressure Reducing Valve

Model: Most Cat® Models

Warranty: Six Months

- Used to regulate pilot or control pressures when bench testing compensating hydraulic pumps
- Valuable for testing the following pumps: 3G-3287, 8J-2344, 8J-4380, 8J-8723, 8J-9362, 9T-5187, 9T-4731, 9T-4732, 9T-6713, and 9T-6714; these pumps are used on a variety of Caterpillar® equipment but are most commonly found on excavators
- These pumps may require more horsepower than what most dealer test benches can deliver; Aidco, Wolff and Schroder test benches with 125 Hp or smaller electric motor need pressure reducing valve to complete proper pump test and adjustment; Cat® Hydraulic Test Center does not need this valve
- In the past dealers have used needle valve assembly identified as item D in Special Instruction Bench Testing Hydraulic Components (SEHS7972); this assembly sends a signal pressure to pump, which de-strokes pump output flow and reduces horsepower demand; valve arrangement is difficult to set and requires constant adjustment to maintain signal pressure during test
- 1U-6392 performs same function as former needle valve arrangement, but is much easier and quicker to set, and will automatically maintain specified signal pressure throughout test; this will save time and improve quality of test
- Used with desired length hoses, valve will remotely control signal pressure to pump
- Pressure-compensating, cartridge-type, pressure-reducing valve; has a locking hand knob to adjust outlet port pressure and manifold with 2 test ports for reading inlet (supply) and outlet (regulated) pressures



Operating range	517 - 10,334 kPa (75 - 1,500 psi)
Rated flow	18.9 lpm (5.6 gpm)
Port sizes	
Tank	3/4 -16 SAE port
Inlet and test	9/16-18 SAE port

Part Number	Description
1U-6392	Pressure Reducing Valve

Hose Assemblies and Quick Disconnects

Warranty: Six Months

- Can be used when pressure testing hydraulic systems with pressures up to 41,500 kPa (6,000 psi); 6D-7726 used for signal pressure source for load sensing pumps. 68,900 kPa (10,000 psi) pressure rating
- The new hose assemblies have the same end connections and hose lengths as the existing hoses, but have a smaller inside diameter, 2 mm (0.080 in) versus 3.18 mm (0.125 in).
- The smaller inside (and outside) diameter makes the hose lighter, more flexible, able to be bundled in a tighter coil, stored in a smaller area, and easier to handle.
- The end connections allow the hose to be used with various existing adapters, fittings, and quick disconnects.

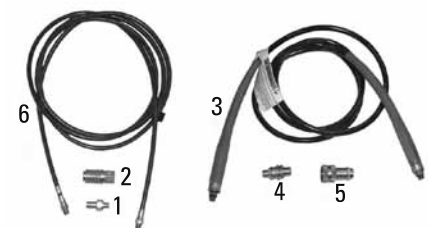

Item	Part Number	Description	Inner Diameter	Length	Connection
1	6V-3965	Nipple Assembly	--	--	9/16 in SAE male-valved
1	6V-3966	Pressure Test Valve, 1/4 in-18 NPTF external	--	--	1/4 in NPT male-valved
1	6V-3989	Plain Nipple, Internal, 1/4 in NPT	--	--	1/8 in NPT female non-valved

(Continued)

Hose Assemblies and Quick Disconnects (Continued)

Warranty: Six Months

Item	Part Number	Description	Inner Diameter	Length	Connection
2	6V-4143	Coupler Assembly	--	--	1/8 in NPT female-valved
2	6V-4144	Coupler Assembly (For 42000 kPa)	--	--	1/4 in NPT female-valved
3	6D-7726	Hydraulic Hose (2)	6 mm (0.236 in)	3050 mm (10 ft)	1/4 in NPT male
4	1P-2375	Coupler Assembly Quick Connective (Male)	--	--	1/4 in NPT male-valved (68,900 kPa)
5	1P-2376	Coupler Assembly Quick Connective (Female) (2)	--	--	1/4 in NPT female-valved (68,900 kPa)
6	177-7860	Hose Assembly	3.2 mm (0.12 in)	3050 mm (10 ft)	1/8 in NPT male both ends
6	177-7861	Hose Assembly	3.2 mm (0.12 in)	4270 mm (14 ft)	1/8 in NPT both ends
6	177-7862	Hose Assembly	3.2 mm (0.12 in)	5486 mm (18 ft)	1/8 in NPT both ends
6	1U-5757	Hose Assembly	2 mm (0.080 in)	1830 mm (6 ft)	1/8 in NPT by 7/16-20 x 37° JIC (not shown)

Test Port Adapters

Model Usage: Paving Products, Work Tools, and Many Other Cat® Models

Warranty: Six Months

- Used to convert different sizes of metric DIN 3852 ports to SAE No.6 (9/16 inch - 18 thread) port
- Used with 6V-3965 Valved Quick Disconnect Nipple, making connection of test equipment much easier
- Each adapter requires a corresponding seal
- DIN 3852 metric ports can be found on 215B and 225 Excavator hydraulic pumps with part numbers 9T-4731 and 9T-4732 as well as many other products

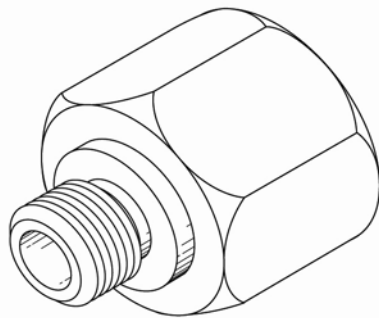

Part Number	Corresponding Seal Part No.	Description
367-9110	3E-4296	M8 X 1 Thread to SAE No. 6 (9/16 in - 18 Thread) Port
8C-6862	8C-5199	M10 x 1 Thread to SAE No. 6 (9/16 in - 18 Thread) Port
8C-6863	8C-5200	M12 x 1.5 Thread to SAE No. 6 (9/16 in - 18 Thread) Port
8C-6864	8C-5201	M14 x 1.5 Thread to SAE No. 6 (9/16 in - 18 Thread) Port

Automatic Welding

Bore Welding Groups

Model: All Models

Warranty: Six Months

European Union compliant, CE marked (276-2067 and 276-2068)

- Increases welding and machining productivity
- Reduces repair and equipment downtime
- Extends the life of capital equipment
- Extension and torch attachment system eliminates liner installment when adding and removing components
- Central mount for easy interface with any boring bar
- One switch, one knob; interfaces with your wire feeder
- Welds in any axis — vertical, horizontal, or inverted
- Lightweight and highly portable

Part Number	Description	Size
276-2066	Bore Welding Group	69.85 - 304.8 mm (2.75 - 12 in) diameter
276-2067	Bore Welding Group	69.85 - 304.8 mm (2.75 - 12 in) diameter
276-2068	Bore Welding Group	22.35 - 304.8 mm (0.88 - 12 in) diameter
Service/Repair Parts		
137-2693	Head Extension	76.2 mm (3 in)
137-2699	Tip	#00
137-2723	Tip	0.76 mm (0.030 in)
137-2724	Tip	1.14 mm (0.045 in)
137-3387	Nozzle	--
276-2069	Bore Kit	22.35 - 76.2 mm (0.88 - 3 in) diameter
276-2070	Swivel	#1
276-2071	Swivel	#2
276-2072	Torch Adapter	--

Part Number	Description	Size
Service/Repair Parts (Continued)		
276-2073	Tip	1.14 mm (0.045 in)
276-2074	Tip	1.14 mm (0.045 in)
276-2075	Nozzle	#00
276-2076	Nozzle	#0
276-2077	Liner	0.58 - 1.14 mm (0.023 - 0.045 in)
276-2078	Mounting Rod	--
276-2079	Power Cord	--
276-2080	Cable	--
276-2081	Cable	--
276-2082	Cable	--
277-8325	Cable	--
Additional Service Parts for 276-2068 Bore Welding Group		
137-2698	Torch Assembly	#00
137-3585	Torch Assembly	#0

Bore Welding Groups**Discontinued — Service Parts Available****Reference**

NEHS0665, Tool Operating Manual

Service/Repair Parts ¹		
Part Number	Description	Detail
137-2682	Bulk Liner	--
137-2692	Wire Feed Conduit	1.52 m (5 ft)
137-2693	Head Extension	76.2 mm (3 in)
137-2698	Torch Assembly	#00
137-2699	Tip	#00
137-2707	Power Control Cable	--
137-2709	Power Cable	--
137-2723	Tip	#0.030
137-2724	Tip	#0.045

Service/Repair Parts ¹		
Part Number	Description	Detail
137-2725	Offset Support	--
137-2728	Conduit Wire, 91.44 cm (3 ft)	--
137-3386	Nozzle Holder	--
137-3387	Nozzle	--
137-3585	Torch Assembly	#0
140-0458	Control Cable	--
155-4152	Speed Reduction Pulley	Used with torches (#9-12)
155-4153	Speed Reduction Belt	Used with torches (#9-12)

¹All part numbers in the table have a six month warranty

(Continued)

282-2489 Wire Feeder

Model: All Models

Warranty: Six Months

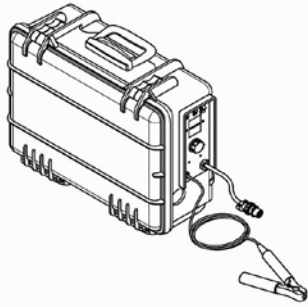

- Used with 276-2066, 276-2067, and 276-2068 Bore Welders to weld worn or distorted bores (wire feeder designed with Caterpillar® specifications)
- Automatic voltage sensing makes this wire feeder perfect for bore welding and general applications
- Includes stub burn-off to prevent wire from sticking inside bore
- Weld wire is non-conductive until gun trigger is pressed
- Operates entirely on Arc Voltage utilizing a single weld power supply
- Internal contact and gas solenoid valve
- Gas flow meter mounted on unit for ease of use
- Stainless steel case

Reference

NEHS0628, Tool Operating Manual

Continuous duty rating	450 amp with 12 ft MIG gun
Meters	Voltage, amperage, and wire feed speed
Overall size	44.5 x 23 x 32 cm (17.50 x 9.0 x 12.5 in)
Spool size and weight	8 inch thru 30 lb spools (including 14 lb coils of wire)
Polarity	Straight or reverse
Included Service/Repair Parts:	
Drive Roll Kit	
Work Clip Assembly	

Part Number	Description	Size
282-2489	Wire Feeder	44.5 x 23 x 32 cm (17.50 x 9.0 x 12.5 in)
Service/Repair Parts		
1U-6164	Outlet Wire Guide	--
1U-6165	Outlet Wire Guide	--
1U-6166	Outlet Wire Guide	--
1U-6171	Drive Roll	--
1U-6172	Drive Roll	--
1U-6173	Drive Roll	--
1U-6174	Drive Roll	--
1U-6175	Drive Roll	--
1U-6176	Potentiometer	--
1U-6179	On-Off Switch	--
1U-6180	Gas Inlet Fitting	--
1U-6183	Connector Gun Switch	--
1U-6184	Drive Roll Smooth V	--
1U-6185	Drive Roll Smooth V	--
1U-6188	Volt Meter	--
1U-6190	Inch Switch	--
1U-6191	Drive Roll Key	--
1U-6192	Fuse Holder	--

(Continued)

282-2489 Wire Feeder (Continued)

Model: All Models

Warranty: Six Months

Part Number	Description	Size
Service/Repair Parts (Continued)		
1U-6194	Outlet Guide	--
1U-7645	Drive Roll	--
1U-9005	Nozzle	--
1U-9006	Nozzle	--
1U-9007	Contact Tip	--
1U-9008	Contact Tip	--
1U-9011	Contact Tip	--
1U-9012	Contact Tip	--
1U-9014	Insulator	--
1U-9016	Switch Assembly	--
1U-9018	Liner	3.66 m (12 ft)
1U-9019	Liner	3.66 m (12 ft)
1U-9021	Liner Retaining Nut	--
1U-9025	Handle	--
4C-6610	Input Connector	--
4C-6612	Hub Pin	--
4C-8214	Liner	4.57 m (15 ft)
4C-8215	Liner	4.57 m (15 ft)
4C-8216	Liner	4.57 m (15 ft)
4C-8218	Switch Cable Extension	--

Hydraulic and Portable Boring Bars

Model: All Cat® Machines

Warranty: Six Months

- Used to repair worn bores — lowers customer machine operating costs and increases service shop revenue
- Used with discontinued 1U-9600 Welding Group
- Easy to set up and operate
- One set-up for machining and welding (increases efficiency and produces more reworked holes per hour)
- Mounting hardware allows machining of hole before welding (helps eliminate impurities in weld)
- 2 in-line bores can be welded and machined simultaneously (maximizes production by machining 1 bore while welding the other)

Portable Boring Bar Unit (110 and 220 Volts)

- Designed as light-duty boring machine
- Suited for field applications, small shops, and light machining

Hydraulic Boring Bar Unit

- Used to machine bores on dozer frames, loader lift arms, center hitches, scraper hitches, and many other locations
- Also used to counter bore and spot face

Boring Bar Power Units

- Exclusive load sensing hydraulic feed
- Remote pendant control
- Specially designed six-finger centering cones provide quick, accurate bar centering, even on badly worn bores
- Adjustable aluminum support bearings will rigidly support bar, feed/drive unit, and Bore Welder
- Prehardened to Rc65 and broached on 101.6 mm (4.00 in) centers for tool holders

Drive Units

- Available with either hydraulic or electric drive

End-Drive Feed Unit

- Mounts on the end of the bar, providing access to most boring/welding applications

Thru-Drive Feed Unit

- Mounts anywhere along the bar, providing access to virtually any boring/welding application

References

SEHS8985, Special Instruction, Using the 1U-8660 Boring Bar Hydraulic Unit and Attachments

NEHS0579, Tool Operating Manual, Portable Boring Bar Unit

NEHS0513, Tool Operating Manual, Using the 1U-9600 Welding Group

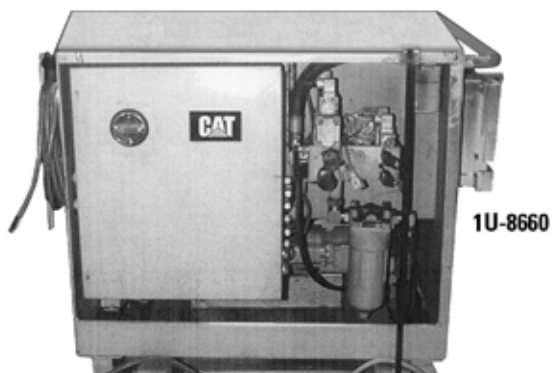

(Continued)

Hydraulic and Portable Boring Bars (Continued)

Model: All Cat® Machines

Warranty: Six Months

Part No.	Power	Gear Pump	Hydraulic	Pump Reser-voir	System Relief Valve	Back Relief Valve	Speed Pressure	Full Load RPM	No Load RPM	Input	Output	Weight of Power Unit	Weight Feed and Drive
Hydraulic Boring Bar													
1U-8660	45 amps at 230 VAC, 27 amps at 460 VAC	--	150 L (40 gal)	--	--	--	--	--	--	--	--	408 kg (900 lb)	--
Portable Boring Bars													
9U-5730	110 V, single-phase, 60 Hz, 1725 RPM	3.8 lpm (1.0 gpm) at 1800 RPM	5.7 lpm (1.5 gpm)	2,400 kPa (348.09 psi)	2070 kPa (300 psi)	965 kPa (140 psi)	4	100 / 150 / 260 / 420	170 / 250 / 450 / 700	900 W	500 W	73 kg (160 lb)	33 kg (72 lb)
9U-5889	220 V, single-phase, 50 Hz, 1425 RPM	3.2 lpm (0.84 gpm) at 1500 RPM	5.7 lpm (1.5 gpm)	2,400 kPa (348.09 psi)	2070 kPa (300 psi)	965 kPa (140 psi)	4	100 / 150 / 260 / 420	170 / 250 / 450 / 700	900 W	500 W	73 kg (160 lb)	33 kg (72 lb)

Boring Bar Selection Chart

Boring Bar Selection Chart

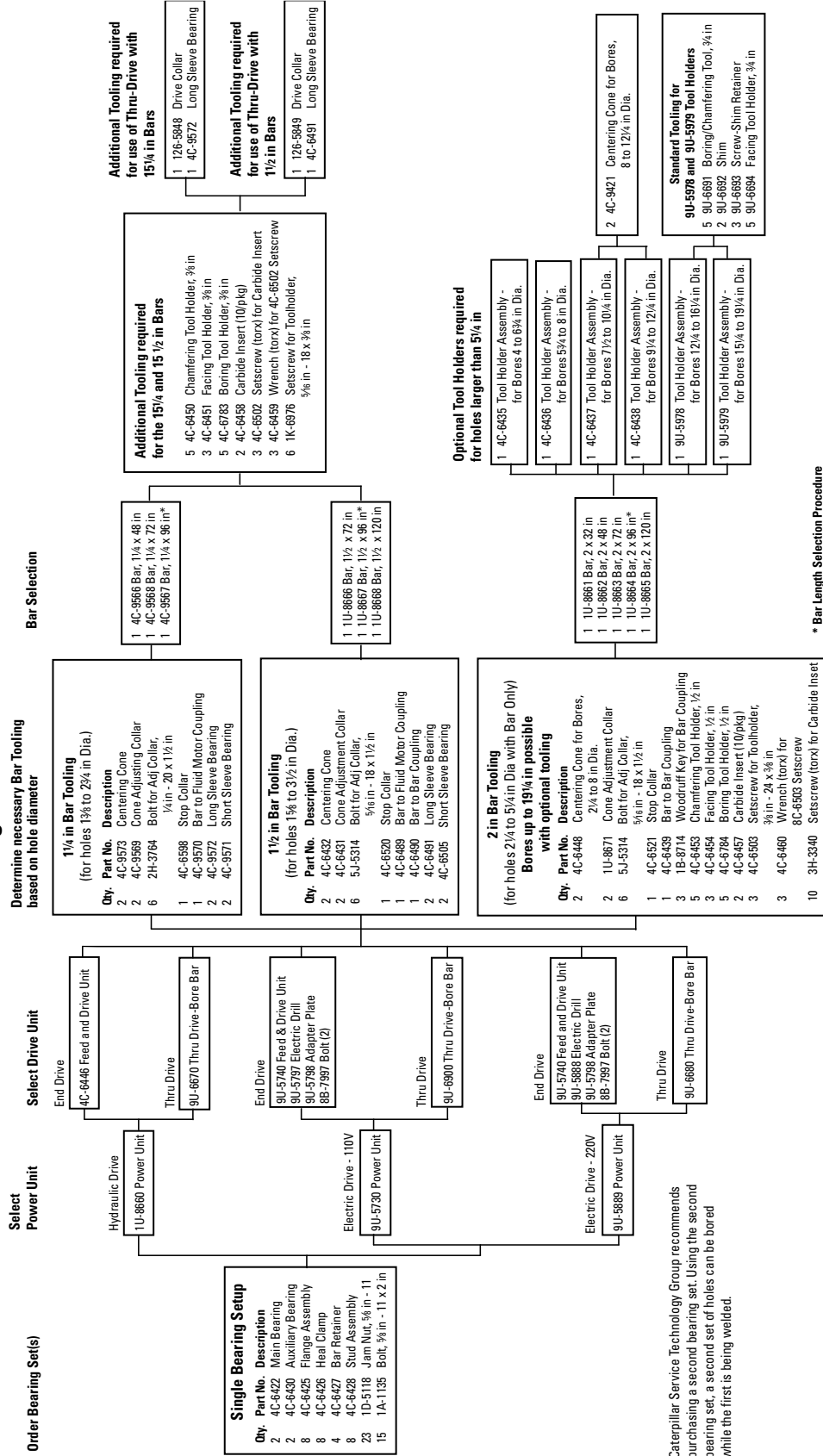

Auxiliary Power Supply

Auxiliary Power Units

Model: Off-Highway Trucks, 784B, 784C Off-Highway Tractors

Warranty: None

- Replaces discontinued 1U-5000 Auxiliary Power Unit (APU)
- Used to provide DC electric and hydraulic power to recover (tow) disabled truck or tractor — provides auxiliary hydraulic power for steering and brake modulation and to actuate hoist cylinders for dumping loads on disabled machines
- Used with 1U-5525 Attachment Group (contains hydraulic fittings, hoses, and electrical cables needed to connect tractor or truck to APU)
- Used as a portable 24 Volt, 35 Amp battery charger
- Integrated lift points for easy attachment to lifting device
- Electric start and easy to use controls
- Large units feature full enclosure for extended outdoor use



Repair Information

PortaCo Inc.

1805 2nd Avenue North

Moorhead, MN 56560-2310

Phone: (218) 236-0223

Fax: (218) 233-5281

Email: info@portaco.com

D60S09-F7-S Auxiliary Power Unit	
Power Supply	Cat® Turbocharged Diesel, 60 Hp
Electrical Output (alternator)	24 Volt, 35 Amp
Hydraulic Output (pump)	38 lpm (10 gpm) at 24821 kPa (3600 psi)

Reference

Manufacturers Operating Manual

SEHS8880, Special Instruction, Using the 1U-5525 Attachment Group

D25S12-22-S Auxiliary Power Unit	
Power Supply	Lombardini Diesel, 25 Hp
Electrical Output (alternator)	24 Volt, 35 Amp
Hydraulic Output (pump)	38 lpm (10 gpm) at 17236 kPa (2500 psi)



Uninterruptible Power Supply

Uninterruptible Power Supply Tools

Model: Uninterruptible Power Supply (UPS) 250

Warranty: None

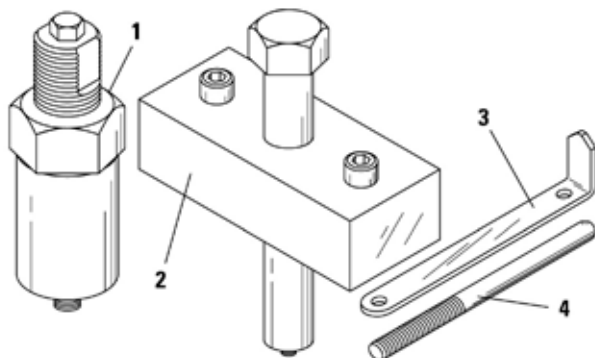

190-8379 Insertion Tool Group

- Used to insert bearing cartridge onto flywheel assembly

190-8385 Removal Tool Group

- Used to remove bearing cartridge from flywheel assembly

190-8386 Rotor Shim Tool (4 required)

- Used to protect rotor assembly during installation and removal of bearing cartridge

190-8380 Spare Shim Kit

- Used to shim upper or lower bearing
- Shims included in kit: (shims are not sold separately)
- 190-8381 Brass Shim — 0.05 mm (0.002 in), qty 8
- 190-8382 Brass Shim — 0.13 mm (0.005 in), qty 4
- 190-8383 Brass Shim — 0.25 mm (0.010 in), qty 2
- 190-8384 Brass Shim — 0.50 mm (0.020 in), qty 1

191-5217 Guide Pin (2 required)

- Used to retain proper alignment of bearing cartridge on flywheel assembly during installation or removal

References

Other UPS Products:

203-3971 Caterpillar UPS View Software Group and

190-8487 Vacuum Pump Oil

Item	Part Number	Description
1	190-8379	Insertion Tool Group
2	190-8385	Removal Tool Group
3	190-8386	Rotor Shim Tool

Item	Part Number	Description
4	191-5217	Pin Guide

224-3145 Drain Service Group

Essential Tool

Model: UPS 300

Warranty: None

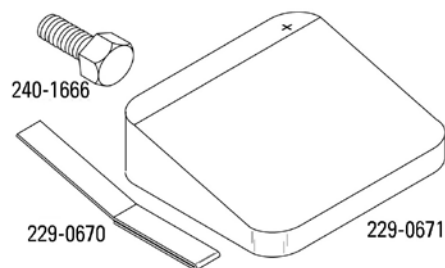

- Used to service charge drain load cells on Uninterruptible Power Supply (UPS) 300

Part Number	Description	Quantity
224-3145	Drain Service Group	--
Service/Repair Parts		
229-0670	Contact Strip	4
229-0671	Test Wedge	1
240-1666	Bolt	1

216-7886 Rotar Position Sensor Shim Kit

Model: Uninterruptible Power Supply (UPS) 250/500/750 and 300/600/900

Warranty: Six Months

- Used to set gap between Rotar Position Sensor and commutation wheel
- Includes ten 5 mil shims with 0.373 OD and 0.165 ID and ten 10 mil shims with 0.390 OD and 0.157 ID

Part Number	Description
216-7886	RPS Shim Kit

203-3971 Caterpillar® UPS View Software Group for UPS 250

Model: Uninterruptible Power Supply (UPS) 250/500/750 and 300/600/900

Warranty: None

Caterpillar® UPS View is a monitoring software designed to run on a personal computer under Microsoft Windows. With Caterpillar® UPS View you can monitor the Uninterruptible Power Supply (UPS) 250/500/750 or 300/600/900 in real time and display these variables on the computer:

- Some of the data that is available in current, voltage, rotor speed, temperatures of components and event logs
- Telemetry data, such as voltage, current and temperature are compared to desired range
- Logged telemetry data can be saved to a disk
- Configure data to be displayed as numerals, bar graphs or scrolling history graphs
- Screen can be customized to rearrange, group or hide
- User can monitor UPS's operation remotely (must use analog phone lines and analog modem must be installed in PC)
- User can setup software with alarm(s) and have operator(s) paged if alarm occurs
- Connect to UPS using an analog modem, an RS-232 or RS-485 port or a network

Ordering Information

- Caterpillar® UPS View software can be ordered through the Corporate Literature Distribution System.
- 203-3971 Caterpillar® UPS View Software Group includes software on a floppy disk, a manual, and a DB9 Male/Female Communications cable 15 feet long.

Specifications/Technical Information - PC Requirements

- IBM PC compatible with 133 MHz Pentium Processor or a compatible processor
- 16 Mb of RAM
- 3.5 inch 1.44 Mb diskette drive
- Built-in pointing device or mouse
- TCP/IP Network Protocols and UDP/IP Network Protocols
- Analog modem for communicating over analog phone lines
- Network Interface Card (NIC) for remote monitoring over a network

Software

- Microsoft Windows 95, 98 or NT4.0

Reference

SEBU7311, Uninterruptible Power Supply (UPS) 250 Manual

Uninterruptible Power Supply

203-3971 Caterpillar® UPS View Software Group for UPS 250 (Continued)

Model: Uninterruptible Power Supply (UPS) 250/500/750 and 300/600/900

Warranty: None

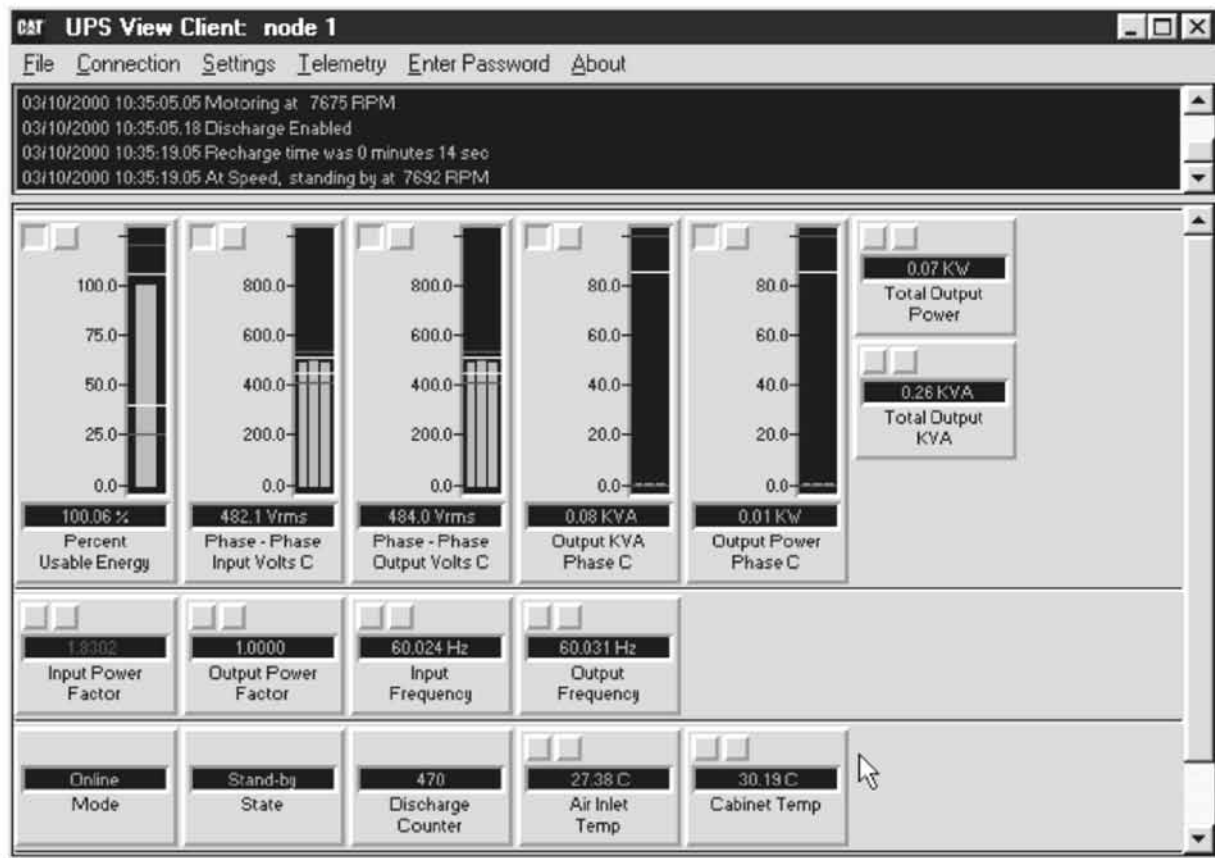

Typical Caterpillar UPS View Software Screen Shot

Part Number	Description
Other UPS Products	
190-8487	Vacuum Pump Oil
190-8379	Insertion Tool Group
190-8380	Spare Shim Kit
190-8385	Removal Tool Group
190-8386	Rotor Shim Tool
191-5217	Pin Guide
216-7886	RPS Shim Kit

Major Equipment

Diagnostic Tooling for Uninterruptible Power Supply (UPS) Systems

Essential Tool

Model: UPSB130 (60 HZ), UPSB125 (50 HZ)

Warranty: Manufacturer's

- The tools assist in servicing the battery racks associated with double conversion UPS

355-8573 Cellcorder (Alber CRT-400)

European Union compliant, CE marked

- 256 MB Flash drive
- BAS software
- Test lead assembly clips
- Two-wire cord with IEC-320 plug
- 5 VDC, 4 Amp desktop power supply
- Carry case
- Shoulder strap
- User guides provided



Part Number	Description
355-8573	Cellcorder (Alber CRT-400)

355-8574 Component Tester (BK-815)

- Large high contrast LCD display
- Transistor leakage test
- Capacitance zero adjustment
- Diode and SCR test, LED test, and battery test mode
- 9 VDC battery power source



Part Number	Description
355-8574	Component Tester (BK-815)

356-2002 Component Carry Case (BK)

- Durable cordura nylon construction
- Protects instruments, 355-8574
- Room for test leads
- Dimensions: 102 x 64 x 203 mm (4 x 2.5 x 8 in)



Part Number	Description
356-2002	Component Carry Case (BK)

355-8575 Power Quality Analyzer (Fluke 43B)



- European Union compliant, CE marked
- TPI flat tipped slim-reach probes
 - TP4 round slim-reach probes
 - i400S AC current clamp
 - Optically isolated USB interface adapter
 - Rechargeable battery pack (installed)
 - Line voltage adapter/battery charger
 - Shielded banana-to-BNC adapter
 - Software and users manual on CD-ROM
 - Users manual/application guide
 - Hard carry case

Part Number	Description
355-8575	Power Quality Analyzer (Fluke 43B)

356-1999 Current Probe (Fluke i2000)



- European Union compliant, CE marked
- Flex current probe
 - Dual banana-to-BNC adapter
 - Cable length: 2 m (6.6 ft)
 - Molded 4 mm (0.16 in) safety plug output connection (not integrated)
 - 178 mm (7 in) maximum conductor diameter
 - Instruction manual

Part Number	Description
356-1999	Current Probe (Fluke i2000)

355-8577 Fan Test Harness Adapter



- Four connector test harness
- X pattern harness
- Overall length: 150 mm (6 in)

Part Number	Description
355-8577	Fan Test Harness Adapter

355-8578 Fan Test Harness



- Test harness with connector
- Overall length: 2.5 m (8.2 ft)

Part Number	Description
355-8578	Fan Test Harness

355-8579 Thermal Grease

- Thermal Grease in syringe type dispenser
- Promotes proper heat transfer from semiconductor components

Part Number	Description
355-8579	Thermal Grease



355-8580 Test Kit (IGBT)

- Includes carry case

Part Number	Description
355-8580	Test Kit (IGBT)



356-2003 Lead and Probe Accessory Kit (Fluke TLK225)

- Alligator clip set
- Hook clip set
- Pincer clip set
- Large alligator clip set
- Test probe set
- Silicone test lead set
- Six-pocket storage pouch

Part Number	Description
356-2003	Lead and Probe Accessory Kit (Fluke TLK225)



356-5036 Torque Screwdriver (CDI Torque Products)

- Positive locking pull-down adjustment knob
- Trilobular comfort grip
- Universal 1/4 inch hex bit holder with magnet
- Cam-over torque limiting clutch
- Auto lock in counterclockwise rotation
- Dual scale, calibrated dual-direction read out in handle
- Torque range: 0.565 to 4.52 N-m (5 to 40 lb in)
- Certificate of calibration traceable to N.I.S.T.

Part Number	Description
356-5036	Torque Screwdriver (CDI Torque Products)



356-5037 Extended Length Test Probe (EZ Hook)



- Long handle test probe
- 60 inch lead length, 30 inch handle length
- 18 AWG pvc test lead with shrouded right-angle banana plug

Part Number	Description
356-5037	Extended Length Test Probe (EZ Hook)

356-5038 Torque Wrench (Cementex)



- Drive size: 3/8 inch
- Length: 254 mm (10 inch)
- Torque range: 3.4 to 17 N·m (30 to 150 lb in)
- Torque graduation: 0.11 N·m (1 lb in)
- For use up to 1000 Volts
- Tested to ASTM-1505-94 and IEC900 Standards

Part Number	Description
356-5038	Torque Wrench (Cementex)

362-0195 Battery Technician Tool Kit



- Used to work on high voltage systems
- Complies with the IEC 900 standard and ASTM F1505-01 standard
- Help meet requirements of OSHA 1910.331-335, NFPA 70E 2004, and CSA-Z462
- Double-insulated tools for better protection
- Tested to 10,000 VAC and rated for 1,000 VAC when working on live parts
- Marked with international safety symbol
- Kit includes:

#2 Phillips Screwdriver

3/16 inch Cabinet Tip Screwdriver

1/4 inch Extra Long Nutdriver

5/16 inch Extra Long Nutdriver

7/16, 1/2, and 9/16 Open End Wrench

7/16, 1/2, 9/16, and 10 mm Geared Box End Wrench

3/8 inch Square Drive Lever Control Reversible Ratchet

3 and 6 inch Extension Bar with 3/8 inch Square Drive

7/16, 1/2, and 9/16 inch Socket with 3/8 inch Square Drive

7/16, 1/2, and 9/16 inch Deep Well Socket with 3/8 inch Square Drive

5/16 and 10 mm Standard 12 Point Socket with 3/8 inch Square Drive

30 to 200 in-lb Torque Wrench with 3/8 inch Square Drive

Part Number	Description
362-0195	Battery Technician Tool Kit

Double Conversion Battery UPS UPSB220 and UPSB505 Tools

Model Usage: UPSB220, UPSB505

Warranty: Manufacturer's

372-3330 Modified Torx Bit

- Bit is extended with a narrow neck to allow access to the cooling fans

Part Number	Description
1U-9484	Serial Communication Cable
285-3850	USB A/B Communication Cable
372-3330	Modified Torx Bit
372-3331	IGBT Test Kit & Cable



372-3330

372-3331 IGBT Test Kit & Cable

- Supply circuit boards for testing in manual mode



1U-9484 Serial Communication Cable

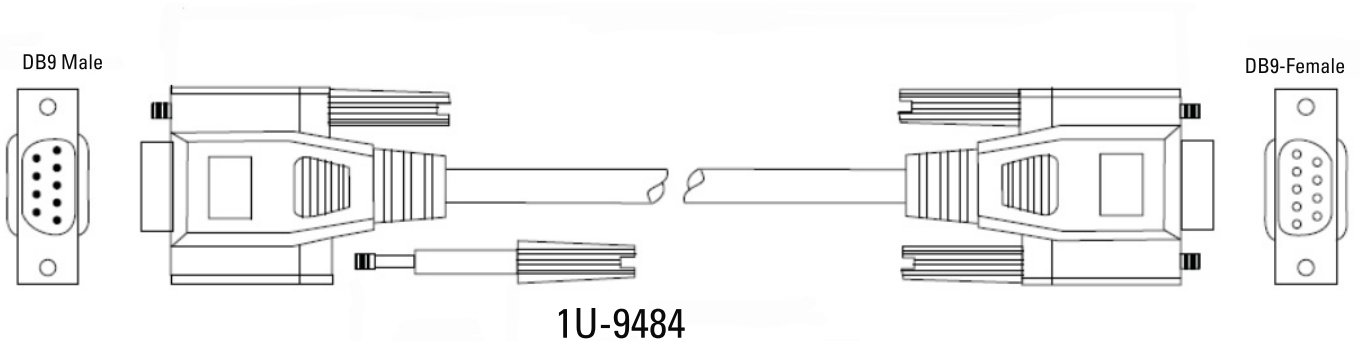

285-3850 USB A/B Communication Cable

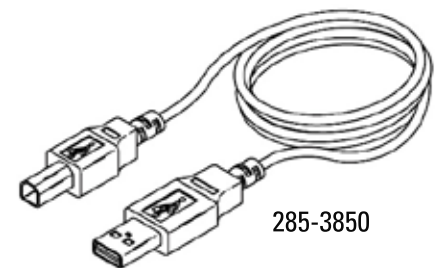

Gas Cutting/Welding Equipment

1U-6469 Heavy-Duty Oxy-Acetylene Deluxe Kit Discontinued—Service Parts Available

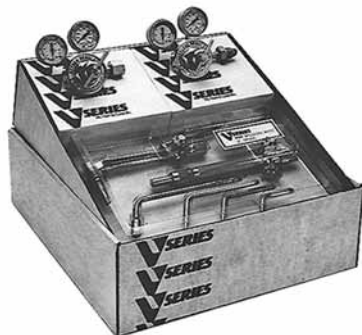

Optional Tips						
Part Number	Description	Metal Thickness (Inches)	Oxygen Pressure (psig)	Acetylene Pressure (psig)	Oxygen and Acetylene Pressure Range (psig)	Heat Output Range BTU/Hour
1U-6469	Heavy-Duty Oxy-Acetylene Deluxe Kit	--	--	--	--	--
Cutting Tips						
1U-6458	Cutting Tip	5/16 - 5/8	30 - 40	7	--	--
1U-6459	Cutting Tip	5/8 - 1	40 - 50	7	--	--
1U-6461	Cutting Tip	2 - 3	50 - 60	9	--	--
1U-6462	Cutting Tip	3 - 4	60 - 75	10	--	--
1U-6463	Cutting Tip	4 - 6	70 - 80	12	--	--
Welding Tips						
1U-6445	Welding Tip	1/64	1	1	--	--
1U-6446	Welding Tip	1/32	1	1	--	--
1U-6447	Welding Tip	3/64	2	2	--	--
1U-6448	Welding Tip	1/16	3	3	--	--
1U-6449	Welding Tip	1/8	5	5	--	--
1U-6450	Welding Tip	3/32	4	4	--	--
1U-6451	Welding Tip	3/16	6	6	--	--
1U-6453	Welding Tip	5/16	8	8	--	--
1U-6454	Welding Tip	3/8	9	9	--	--
1U-6455	Welding Tip	1/2	10	10	--	--
Heating Tips						
1U-6479	Heating Tip	--	--	--	2 - 6	30,000 - 51,000
1U-6480	Heating Tip	--	--	--	3 - 7	44,000 - 74,000
Replacement Parts						
1U-6472	Torch Handle	--	--	--	--	--
1U-6477	Mixer	--	--	--	--	--
1U-6474	Cutting Attachment	--	--	--	--	--
4C-4132	Oxygen Regulator, 2-Stage HD	--	--	--	--	--
4C-4129	Oxygen Regulator, Single Stage HD	--	--	--	--	--

Major Equipment

(Continued)

1U-6469 Heavy-Duty Oxy-Acetylene Deluxe Kit (Continued)
Discontinued—Service Parts Available

Optional Tips						
Part Number	Description	Metal Thickness (Inches)	Oxygen Pressure (psig)	Acetylene Pressure (psig)	Oxygen and Acetylene Pressure Range (psig)	Heat Output Range BTU/Hour
Replacement Parts (Continued)						
4C-4128	Acetylene Regulator, Single Stage HD	--	--	--	--	--
4C-4131	Surge Guard for Oxygen Regulator	--	--	--	--	--

4C-4113 Heavy-Duty Oxy-Propane Deluxe Kit — Vac Pac

Warranty: Six Months

- Cuts to 25.4 mm (1 in) metal (to 152.4 mm [6 in] with optional tips)
- Heating output at 30,000 to 100,000 BTU/hour
- Display box not included

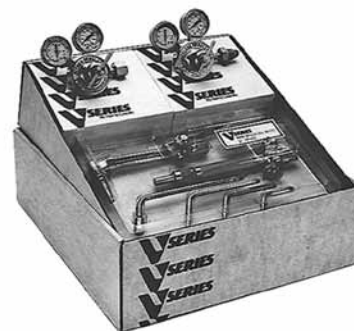

Kit Includes
Welding Handle
Cutting Attachment (Propane)
HD Oxygen Regulator
HD Propane Regulator
Striker
Cover Goggles
Twin T-Hose, 6.35 mm x 6.1 m (1/4 in x 20 ft)
Instruction Manual

Optional Tips							
Part Number	Description	Metal Thickness (Inches)	Oxygen Pressure (psig)	Propane Pressure (oz)	Tip Size	Oxygen psi	Fuel Gas psi
4C-4113	Heavy-Duty Oxy-Propane Deluxe Kit - Vac Pac	--	--	--	--	--	--
Cutting Tips							
4C-4114	Cutting Tip	3/8 - 5/8	30 - 40	4 - 7	--	--	--
4C-4115	Cutting Tip	5/8 - 1	35 - 50	4 - 7	--	--	--
4C-4116	Cutting Tip	1 - 2	40 - 55	4 - 7	--	--	--
4C-4117	Cutting Tip	2 - 3	45 - 60	4 - 7	--	--	--
4C-4118	Cutting Tip	3 - 6	50 - 75	4 - 7	--	--	--
Brazing Tips							
9U-6715	Brazing Tip	--	--	--	4N	20	4 oz
9U-6716	Brazing Tip	--	--	--	6N	25	4 oz - 2 lb
Replacement Parts							
4C-5833	Mixer	--	--	--	--	--	--
4C-4159	Cutting Attachment	--	--	--	--	--	--
4C-4131	Surge Guard for Oxygen Regulator	--	--	--	--	--	--

Major Equipment

MIG/TIG Flowmeter Regulators

Warranty: Six Months



- Construction incorporates regulator and flowmeter into one compact unit
- Flow to 70 SCFH
- Strong easy-to-read Lexan flow tube and cover
- Flow tube is easily changed for different gases
- Dual calibration on argon/carbon dioxide flow tube
- Regulator is pre-set at 50 psig
- Flowmeter is not affected by downstream pressure variations
- Sensitive needle valve for fingertip control
- UL listed

Gas	Part Number	Flow Capacity (SCFH)	Cylinder Connection	Delivery Rate (SCFH)
Argon	4C-4125	0-70	580	70
Carbon Dioxide	4C-4126	0-70	320	70

MIG/TIG Flowgauge Regulators

Warranty: Six Months



- For accurate measurement of gas flow to 40 SCFH
- Sensitive brass adjusting key provides smooth action, and fingertip control
- Lightweight, rugged design
- Easy-to-read gauges
- UL listed

Gas	Part Number	Flow Capacity (SCFH)	Cylinder Connection	Delivery Rate (SCFH)
Argon	4C-4123	0-40	580	40

Twin Welding Hose

Warranty: Six Months



Part Number	Dimensions
1U-8215	4.76 mm x 3.66 m (3/16 in x 12 ft)
1U-8217	6.35 mm x 6.1 m (1/4 in x 20 ft)
1U-8218	6.35 mm x 15.25 m (1/4 in x 50 ft)

1U-6573 Circle Cutting Attachment

Warranty: Six Months



- For cutting circles up to 762 mm (30 in) in diameter as well as straight line burning
- Swivel nut permits circle cutting without tangling hoses
- Wheels are adjustable for individual torch height
- Makes better quality cuts possible with hand torches

(Continued)

1U-6573 Circle Cutting Attachment (Continued)

Warranty: Six Months

Part Number	Description
1U-6573	Circle Cutting Attachment

Heating and Flame Cleaning Equipment

Warranty: Manufacturer's Six Months

Repair Information

Harris Calorific Division
 The Lincoln Electric Company
 2345 Murphy Boulevard
 Gainesville, GA 30504
 Phone: (770) 536-8801
 Fax: (770) 535-0544

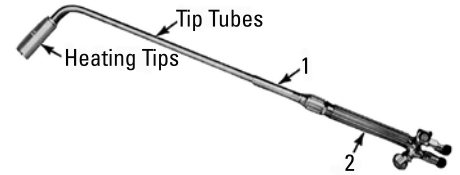

Item	Part Number	Description
1	4C-5830	Mixer
2	4C-5823	Handle

Tip Tubes

Warranty: Manufacturer's Six Months

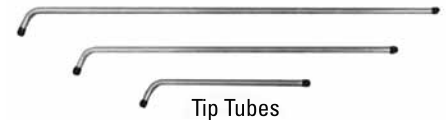

Part Number	Description	Length
Tip Tubes¹		
4C-5832	Tip Tube	381 mm (15 in)
9U-6718	Tip Tube	711.2 mm (28 in)
4C-5831	Tip Tube	914.4 mm (36 in)

¹All part numbers in the table have no warranty

Heating Tips

Warranty: Manufacturer's Six Months

Heating Tips					
Part Number ¹	Oxygen Pressure (PSIG)	Flow (CFH)	Propane Pressure (PSIG)	Flow (CFH)	Heat Output (BTU/hr)
4C-4160	10; 25	160; 320	4; 12	40; 80	101,200; 202,404
4C-4161	1; 45	220; 520	7; 22	55; 130	139,150; 328,900
4C-4162	25; 70	340; 920	8; 25	85; 230	215,050; 581,900
4C-4163	50; 110	640; 1300	10; 30	160; 325	404,800; 822,250
4C-4164	60; 135	720; 1600	14; 40	180; 400	455,400; 1,012,000



¹All part numbers in the table have no warranty

Plasma Arc Cutting

Warranty: None

Before plasma cutting came into existence, service shops wanting to cut steel, stainless steel, or aluminum typically used several different methods. For example, they would use oxygen fuel flame cutting for steel and mechanical means such as shears or power saws for stainless steel and aluminum. With plasma arc cutting (PAC) these shops can now cut all common or exotic metals that conduct electricity.

Plasma arc cutting (PAC) with air uses electricity to create a super-heater gas (called plasma) to melt metal and blow it away. The temperature at the nozzle opening of the cutting torch can reach 33,315.6° C (60,000° F). As a result, the arc melts and removes small portions of metal quickly, leaving behind a smooth, clean cut and a narrow heat affected zone (the area near the cut in which metallurgical changes often occur).

Plasma Arc Cutting Benefits

- **Cost savings** — Even though the initial cost of PAC equipment can be higher than with other cutting methods, the payback per cut can be better with PAC. For example, with faster cutting speeds, and because air and consumables are relatively inexpensive with PAC compared to the cost of gases for oxy-fuel, the payback per cut is less expensive with PAC than with oxyfuel.
- **Cutting speed** — PAC can cut much faster than oxy-fuel, especially on a thickness of less than one inch (see chart below). Besides faster cutting speeds, PAC requires no preheating of the metal, as does oxy-fuel.
- **Versatile cutting capability** — Besides mild steel, PAC does an excellent job of cutting stainless steel and aluminum. It will also do a good job on stacked material.
- **Precision cuts** — Because the faster cutting speeds (along with no preheating) produces a narrow heat-affected zone, metal distortion is minimal. It also causes a very clean cut which means PAC can eliminate the secondary operations needed of other cutting methods.
- **Air versus other gases** — The main advantage of cutting with air is, of course, the availability of air. Where air and power is available, PAC can be easily moved because of its portable design. Using air is inexpensive and safe compared to other cutting gases such as CO₂. PAC, because it uses air, requires no mixing controls. Low volume compressed air is preferred (i.e., 70 psi at 300 ft³/hr).
- **Ease of use** — PAC requires minimum training and is an easy process to use.

Speed Comparison Using Mild Steel (inches per minute — IPM)		
Steel Thickness	PAC IPM	Oxy-Fuel
3 mm (1/8 in)	80 - 120	20 - 30
6.4 mm (1/4 in)	34 - 60	18 - 20
10 mm (3/8 in)	18 - 40	16 - 18

The speed of the cut varies and is determined by the output of the PAC equipment and the thickness of material being cut.

Service Truck Bodies

Dominator® Mechanics Service Trucks From Iowa Mold Tooling Co., Inc. (IMT)

Model: Dominator Mechanic Trucks

Warranty: Manufacturer's

The Dominator® mechanics service trucks are used by construction machinery dealers, railroads, municipal fleets, general contractors, implement dealers, and rental companies.

Standard features on the Dominator series bodies include:

- Enhanced strength and stability for higher crane load
- Patent-pending energy-absorbing boom support
- Multiplex electrical system with programmable logic
- High-intensity light package (optional)
- Maximum compartment storage capabilities



Model	Body Rating	Recommended Crane	Chassis Requirements
DOMCS	12,000 ft-lb (1.7 tm)	Up to, and including, 3203i	11,000 lb – 19,500 GVW
DSC12	12,000 ft-lb (1.7 tm)	Up to, and including, 3203i	10,500 GVW (single rear wheel)
DSC12S	12,000 ft-lb (1.7 tm)	Up to, and including, 3203i	11,030 lb GVW (Sprinter)
DSC20	20,000 ft-lb (2.8 tm)	Up to, and including, 2020	11,000 lb – 19,500 GVW
Dominator I	52,000 ft-lb (7.3 tm)	Up to, and including, 7500	11,000 lb – 26,000 GVW
Dominator II	75,000 ft-lb (10.4 tm)	Up to, and including, 10000	26,000 lb – 33,000 GVW
Dominator III	80,000 ft-lb (11.1 tm)	Up to, and including, 12000	33,000 lb GVW
Dominator IV	95,000 ft-lb (13.3 tm)	Up to, and including, 14000	33,000 lb GVW (single axle); Larger Chassis for Tandem Axel

Options on all Dominator mechanics trucks include:

- Drawers and drawer sets
- Standard adjustable shelves
- 3”H (7.6 cm) divided adjustable shelves
- Crane Stabilizer - manual and hydraulic
- Workbench vises and vise plates
- Work lights and incandescent compartment lights
- Compartment pressurization system
- Compressed Air System / Welder / Generator
- Air compressors ranging from 35 cfm @ 100 psi (6.8 bar) to 110 cfm @ 150 psi (10.3 bar)

For more information, contact:

Iowa Mold Tooling Company, Inc.
 500 Highway 18 West
 P.O. Box 189
 Garner, Iowa 50438-0189
 Phone: 1-800-247-5958
 Email: catdealer@imt.com
 www.imt.com

Material Handling From Iowa Mold Tooling Co., Inc. (IMT)

Model: Telescopic Cranes, Articulating Cranes

Warranty: Manufacturer's



IMT Telescopic cranes feature:

- Cycle times designed for maximum productivity
- Lifting capacities up to 14,000 lb (6350 kg)
- Various winch speeds
- Anti-two-block protection
- Overload shutdown systems
- Cylinder holding valves

Models 2003i — 2020 come standard with tethered remote controls

Models 7500 — 14000 come standard with a fully proportional radio remote control

Models	Crane Rating Range	Maximum Lift Capacity Range	Maximum Horizontal Reach Range	Maximum Horizontal Reach Capacity Range
2003i	8000 ft-lb (1.1 tm)	2000 lb (907 kg)	78" (198 cm)	2000 lb (907 kg)
3203i	12,000 ft-lb (1.6 tm)	4000 lb (1815 kg)	15' (4.6 m)	730 lb (330 kg)
4004i	18,000 ft-lb (2.5 tm)	4000 lb (1814 kg)	16' 0" (4.9 m)	1080 lb (490 kg)
5005i	30,000 ft-lb (4.1 tm)	5000 lb (2268 kg)	20' 0" (6.1 m)	1260 lb (570 kg)
6006i	38,000 ft-lb (5.3 tm)	6000 lb (2722 kg)	22' 0" (6.7 m)	1660 lb (755 kg)
1015	10,500 ft-lb (1.4 tm)	3200 lb (1450 kg)	15' 0" (4.6 m)	650 lb (295 kg)
2020	20,000 ft-lb (2.8 tm)	5000 lb (2268 kg)	20' 0" (6.1 m)	800 lb (362 kg)
2820	28,000 ft-lb (3.9 tm)	5000 lb (2268 kg)	20' 6" (6.3 m)	1270 lb (576 kg)
7500	52,000 ft-lb (7.3 tm)	7500 lb (3402 kg)	30' 10" (6.9 m)	1350 lb (615 kg)
8600	60,000 ft-lb (8.4 tm)	8600 lb (3901 kg)	30' 10" (9.4 m)	1575 lb (715 kg)
9500	68,000 ft-lb (9.5 tm)	9500 lb (4309 kg)	30' 10" (9.4 m)	1800 lb (815 kg)
10000	75,000 ft-lb (10.4 tm)	10,000 lb (4536 kg)	30' 10" (9.4 m)	2030 lb (920 kg)
12000	79,000 ft-lb (11.1 tm)	12,000 lb (5443 kg)	31' 0" (9.4 m)	2200 lb (1000 kg)
14000	97,000 ft-lb (13.5 tm)	14,000 lb (6350 kg)	31' 0" (9.4 m)	2600 lb (1180 kg)

IMT Articulating Cranes

- Easily load and unload materials
- Stow within themselves, freeing up payload space for additional materials
- 35 models with capacities ranging from 18,085 ft-lb to 320,000 ft-lb
- Boom reach options to match lift requirements

Articulating Crane Model Ranges	Maximum Crane Rating Range	Maximum Lift Capacity	Maximum Horizontal Reach	Maximum Horizontal Reach Capacity
Articulating Cranes Models 2.5 tm – 15 tm	18,085 ft-lb - 104,880 ft-lb (2.5 tm - 14.5 tm)	1740 lb - 13,470 lb (790 kg - 6110 kg)	23	715 lb - 1060 lb (325 kg - 480 kg)
Articulating Cranes Models 17tm – 80tm	116,450 ft-lb – 557,665 ft-lb (16.1 tm – 77.1 tm)	12,785 lb – 38,185 lb (5800 kg – 17,320 kg)	56	1280 lb - 6285 lb (580 kg - 2850 kg)



For more information, contact:

Iowa Mold Tooling Company, Inc.
 500 Highway 18 West
 P.O. Box 189
 Garner, Iowa 50438-0189
 Phone: 1-800-247-5958
 Email: catdealer@imt.com
 www.imt.com

SiteStar® Lube Equipment From Iowa Mold Tooling Co., Inc. (IMT)

Model: Open Lube Truck, Enclosed Lube Truck, Lube Skid
 Warranty: Manufacturer's

Open Lube Truck

The IMT SiteStar open lube truck features:

- Additional 70 cubic feet of storage
- Polyethylene tanks that reduce overall vehicle weight
- 260 possible tank configurations

Model	Available Poly Tank Sizes	Available Elliptical Fuel Tanks	Available Rect-angle Steel Fuel Tanks	Available Fluid Systems
SiteStar Open Lube Truck with fuel	75 – 350 gal (284 – 1325 L)	1000 – 2000 gal (3785 – 7570 L)	480 – 800 gal (1817 – 3028 L)	Oil, Anti-Freeze, Water, Oil Salvage, Anti-Freeze Salvage, Grease, and Fuel
SiteStar Open Lube Truck without fuel	75 – 350 gal (284 - 1325 L)	N/A	480 – 800 gal (1817 – 3028 L)	Oil, Anti-Freeze, Water, Oil Salvage, Anti-Freeze Salvage and Grease



Major Equipment

Enclosed Lube Truck

The IMT Site Star enclosed lube truck:

- Shields product tanks and workers from the elements
- Comes in a 13-foot or a 17-foot body
- Uses polyethylene product tanks rather than steel, which means an 80 percent reduction in tank weight. Poly tanks also include cleaner fluid storage, easier tank replacement, and contamination control.

Model	Available Poly Tank Sizes	Available Rectangle Steel Fuel Tanks	Available Fluid Systems	Body Weight	Body Height
13' SiteStar Enclosed Lube Truck	75 – 350 gallon (284 – 1325 L)	480 – 800 gallon (1817 – 3028 L)	Oil, Fuel, Anti-Freeze, Salvage, Anti-Freeze Salvage and Grease	6625 lb (3005 kg)	121" (307.3 cm)
17' SiteStar Enclosed Lube Truck	75 – 350 gallon (284 – 1325 L)	480 – 800 gallon (1817 – 3028 L)	Oil, Fuel, Anti-Freeze, Salvage, Grease	8059 lb (3655.5 kg)	121" (307.3 cm)

Lube Skid

The lightweight IMT SiteStar lube skid easily attaches to and detaches from mechanics truck, giving a flexible selection of lube products to provide lube truck services for fleets.

Model	Weight	Height	Width	Length	Capacity
Lube Skid	3362 lb at full capacity (1525 kg)	54" (137.2 cm)	48" (121.9 cm)	7' 4" (2.3 m)	220 gal (832.8 L)(4-55 gallon polyethylene product tanks)

For more information, contact:

Iowa Mold Tooling Company, Inc.
 500 Highway 18 West
 P.O. Box 189
 Garner, Iowa 50438-0189
 Phone: 1-800-247-5958
 Email: catdealer@imt.com
www.imt.com

Tire Manipulators From Iowa Mold Tooling Co., Inc. (IMT)

Model: TireHandler®

Warranty: Manufacturer's



- Installs and rotates the massive tires on mining and construction equipment
- Available in loader or forklift truck-mounted options
- Accommodates tires up to 25,000 lb
- Includes lateral shifting capability
- Optional quick-coupler attachments and multiple-site vehicle packages available
- Features 390° of body rotation, giving the operator flexibility and control from the security of its integrated control console.

Tire Manipulators From Iowa Mold Tooling Co., Inc. (IMT) (Continued)

Model: TireHandler®

Warranty: Manufacturer's

Tirehand Model	Maximum Lift Capacity	Clamping Span	Tirehand Weight
1449	5000 lb (2267 kg)	55" (1397 mm) to 115" (2921 mm)	2020 lb (916 kg), 3093 lb (1403 kg) with side shift
2551	10,000 (4535 kg)	52" (1321 mm) to 142" (3607 mm)	7865 lb (3568 kg), 9400 lb (4264 kg) with side shift
2557	13,000 lb (5987 kg)	50" (1270 mm) to 160" (4064 mm)	8680 lb (3937 kg), 9,670 lb (4386 kg) with side shift
3565	25,000 lb (11,340 kg)	39" (981 mm) to 162" (4119 mm)	14,951 lb (6781 kg), 19,921 lb (9036 kg) with side shift

For more information, contact:

Iowa Mold Tooling Company, Inc.
500 Highway 18 West
P.O. Box 189
Garner, Iowa 50438-0189
Phone: 1-800-247-5958
Email: catdealer@imt.com
www.imt.com

