

# Off-Highway Truck Engine Brake



A Caterpillar® Engine Compression Brake is available as an upgrade on the 777F, 775F, and 773F trucks. The engine compression brake operates in conjunction with the Automatic Retarder Control (ARC) that is standard on all F-Series trucks. The Cat® Engine Compression Brake with ARC makes braking easier and more efficient. The benefits of the engine compression brake include:

- Up to 35% higher downhill travel speeds
- Up to one additional gear on downhill grades
- Reduced wear on brake components used in retarding applications
- Automated engine braking resulting in decreased operator input and improved controllability
- No additional maintenance or tune-ups outside valve lash checks



# Off-Highway Truck Engine Brake

The compression brakes along with the installation parts and hardware are available through the Caterpillar® parts distribution system. Reference part number 333-9320 for the full parts consist when placing the order.

Engine Compression Brakes are backed by the Caterpillar standard parts warranty. Quality material and strict manufacturing processes ensure Cat parts provide top performance and long life.

Machine	Engine	Engine Arrangement	Engine Serial no.
773F	C27	2275353	EHX02109 & above
775F	C27	2275354	LJX00077 & above
777F	C32	2465457	LJW02110 & above

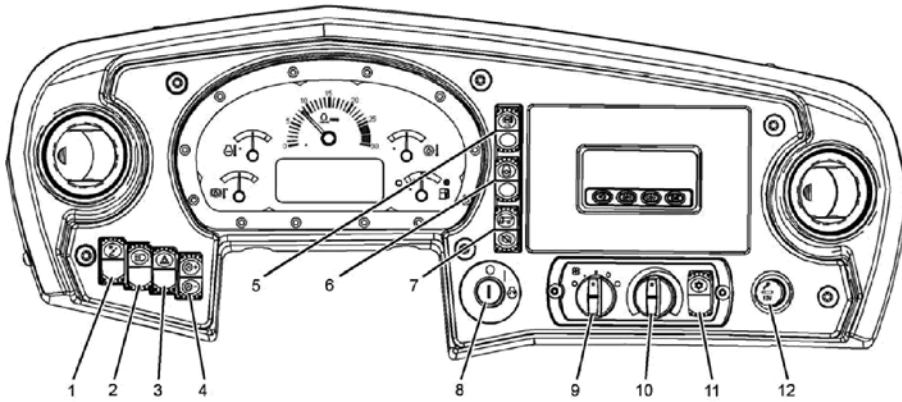

Illustration 45

g01240004

- |  |   |                                   |
|--|---|-----------------------------------|
| (1) Dash panel switch for access lights                  | (5) Switch for automatic retarder control (ARC)     | (8) Engine start switch           |
| (2) Switch for headlights, parking lights and taillights | (6) Engine brake switch (if equipped)               | (9) Fan speed switch              |
| (3) Hazard flasher switch                                | (7) Switch for the front brake system (if equipped) | (10) Temperature variable control |
| (4) Panel light switch                                   |   | (11) Air conditioner switch       |
|  |   | (12) Cigar lighter (12 V)         |

## CAT® DEALERS DEFINE WORLD-CLASS PRODUCT SUPPORT.

We offer you the right parts and service solutions, when and where you need them.

The Cat Dealer network of highly trained experts can help you maximize your equipment investment.

