

ENGINES



The E 23 (IMO II-EPA T3) and E 23B (IMO III-EPA T4F) are available in 8,12,16 and 20 cylinder configurations with continuous power ratings from 1249 bkw (1675 hp) to 3729 bkw (5000 hp).

EMD 710 SERIES ENGINE RATINGS

E 23 / E 23B

Engine	900 RPM		750 RPM	
	BKW	BHP	BKW	BHP
8	1491	2000	1249	1675
12	2237	3000	1561	2495
16	2983	4000	2479	3325
20*	3729	5000	3098	4155

ENGINES AVAILABLE IN THESE CONFIGURATIONS:

- Marine applications
- Stationary power applications
- Drilling applications meeting MODU inclination requirements

* For information on the 20 E 23B model, consult your dealer. Intermittent ratings are also available. Consult your dealer for availability.

EMD® ENGINES ARE CERTIFIED BY



TWO CYCLE ADVANTAGE

ENDURING DESIGN. LEGENDARY HERITAGE.

Over 78,000 EMD® engines have been delivered worldwide since 1935, making it one of the largest medium speed engine families in the world. Constant innovation and refinement have made the EMD E 23 the most efficient and durable engine in its class.

EMD® engines are certified to meet emissions standards worldwide. Largest medium speed operating range from 200 to 900 rpm.

Advantage EMD.

DIESEL (E 23/E 23B)

The E 23 has met the challenges of increasingly stringent global emissions standards through continuous optimization of its proven design. With only minor engine changes, and avoiding high cost technologies such as common rail fuel injection, the E 23B uses proven SCR technology to meet US EPA Tier 4F and IMO III, enabling maximum confidence and minimum risk in your daily operations.

HIGH PRESSURE GAS TECHNOLOGY GAS (E 23B GD)

Direct Injected Gas™ (DIG™), a uniquely designed high pressure gas system utilizes a minimum amount of diesel pilot fuel to enable combustion of natural gas at rates of 95% and greater. Based entirely on the diesel cycle, the EMD DIG™ solution represents one of the cleanest and most fuel efficient gas technologies available.



**TUG BOAT POWERED BY
THE E 23 ENGINE.**

PERFORMANCE ADVANTAGE

SUPERIOR
TRANSIENT RESPONSE.



Cool, high density charge air delivered to the E 23 cylinders across the entire operating range enables rapid power response regardless of the operating point. This allows the E 23 to accelerate from idle (200 RPM) to 100% continuous load and speed (900 RPM) in approximately 13 seconds.

BEST IN-CLASS TRANSIENT RESPONSE

- E 23 offers the performance of a high speed engine with the durability advantage of a medium speed engine.
- Ample power margin throughout the entire operating speed range allows for optimized engine sizing and a single speed reduction gear.
- Avoids engine lugging under demanding vessel maneuvers.
- Accepts 100% block load in constant speed applications.



OPERATING RANGE ADVANTAGE

ENHANCED EFFICIENCY AND CONTROL.

LOWEST IDLE SPEED

(WIDEST MEDIUM SPEED OPERATING RANGE)

- Improves fuel economy vs. competitors up to 11%.
- Enables greater thrust control for better vessel maneuverability, enhanced safety of operation, and extended bumper wear.
- Significantly reduces vibration and noise for maximum crew comfort.
- Results in less engine wear.

VARIABLE SPEED PROPULSION

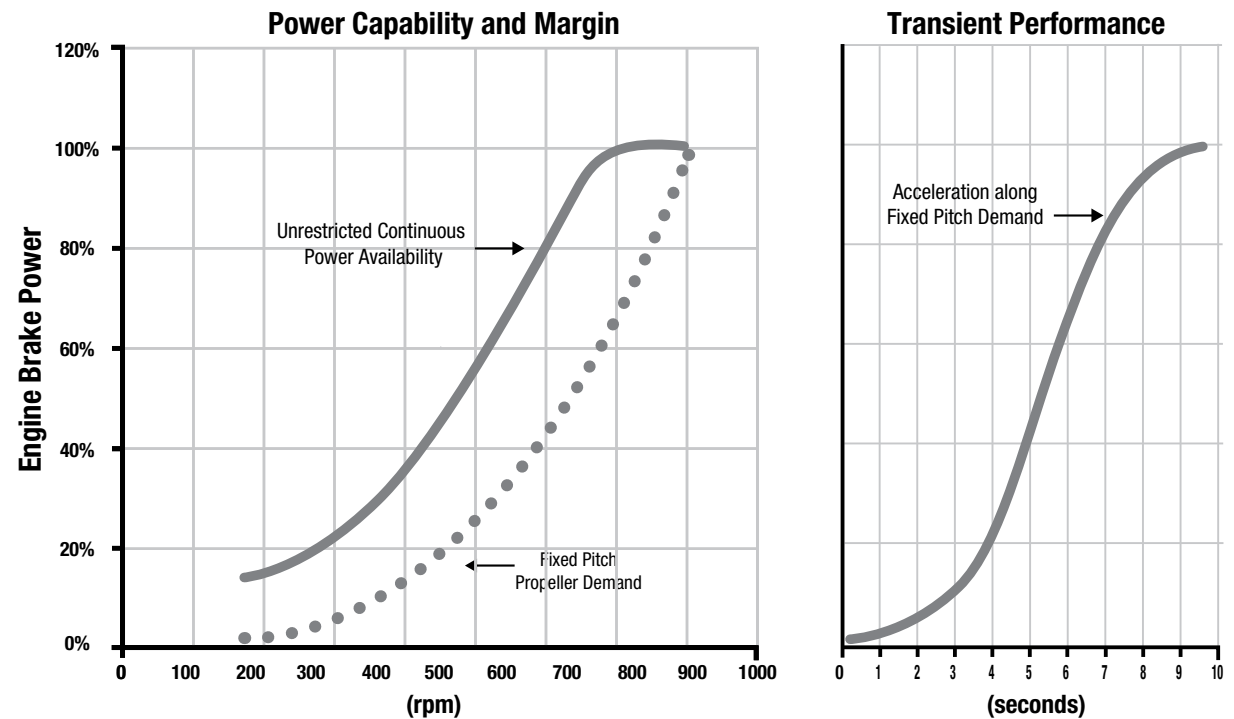

NEXT GENERATION ADVANTAGE

THE E 23B.

INTEGRATED SELECTIVE CATALYTIC REDUCTION (SCR) SYSTEM

A novel approach to a proven, robust technology.

- Reduces NOx in a compact space.
- Allows engine to operate at maximum thermal efficiency for fuel consumption improvements up to 7%.
- Does not significantly affect design or operation of the engine.
- Enables complete maintenance of the SCR within the engine room.
- Minimizes vessel engineering and construction costs.
- Avoids use of complex and high maintenance on-engine technologies such as EGR and common rail fuel injection.

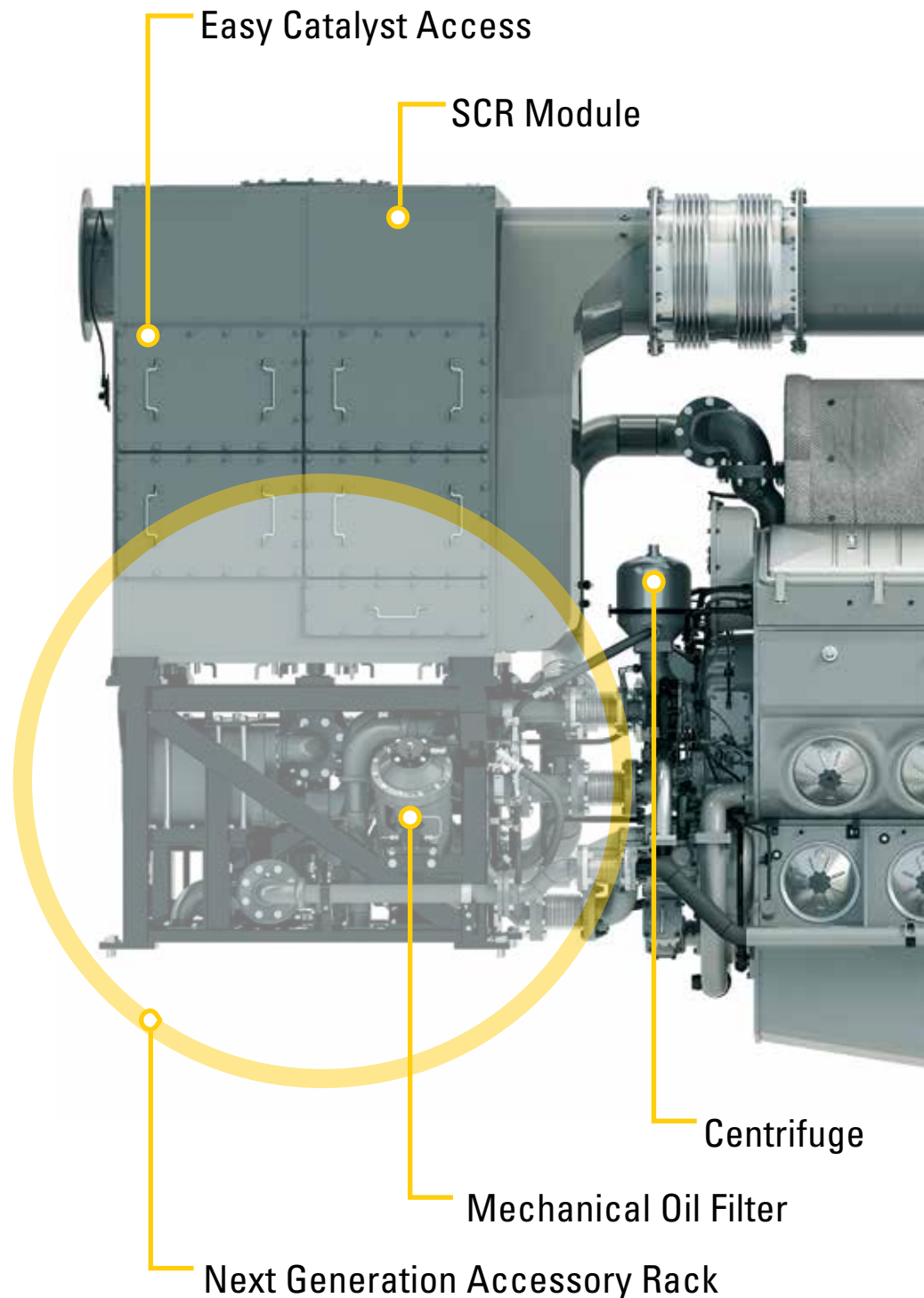

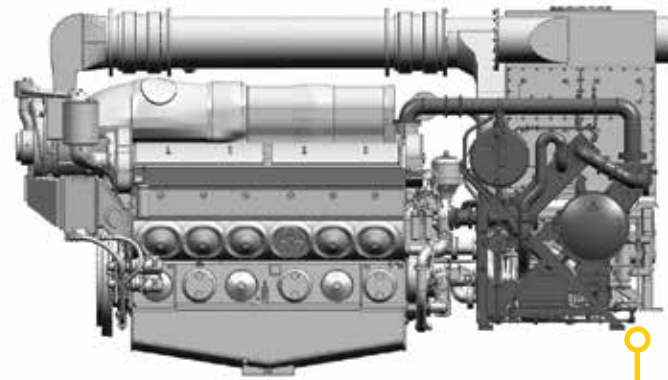
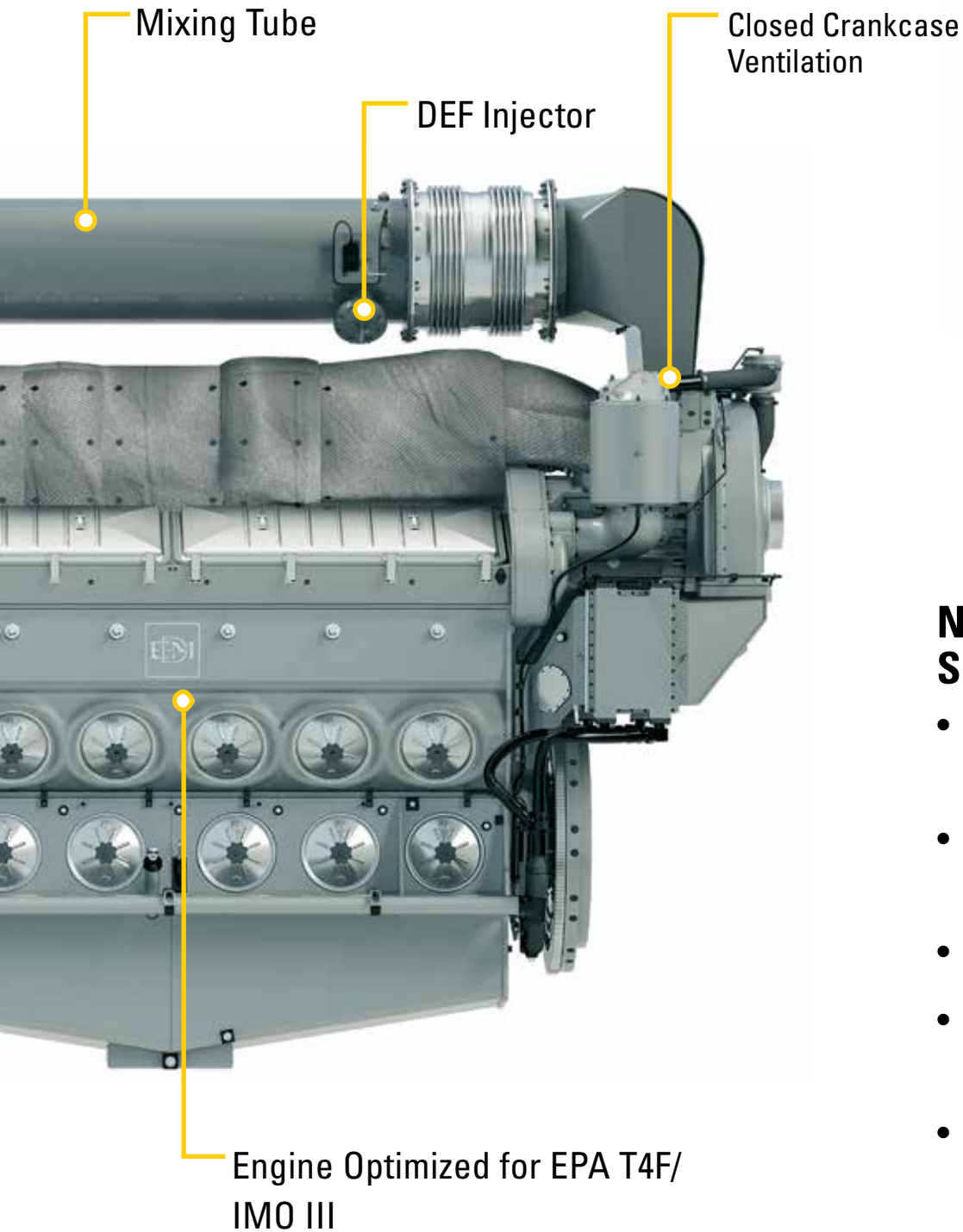

Same Footprint
EPA Tier 4F/IMO III engine (gray)
over EPA Tier 3/IMO II engine (black)

NEXT GENERATION ACCESSORY RACK – SIMPLY INTEGRATED

- Design retains footprint of EPA T3/IMO II models while providing full structural support for the SCR module.
- Mechanical oil filtration reduces operating cost and environmental impact.
- Brazed plate lube oil cooler saves space.
- PTO space claim accommodates up to 10" diameter at free end of engine.
- Bottom plane cooling water connections minimize installed footprint and eliminate trip hazards.

TOTAL COST OF OWNERSHIP ADVANTAGE

MAXIMUM UPTIME.



PARTS • LABOR • FLUIDS

Downtime is expensive. EMD® engines are designed to minimize the amount of time needed for maintenance and repairs in order to maximize your productivity, keeping operational costs to a minimum.

- Reduced fuel consumption over previous models due to EPA T4F / IMO III technologies and low idle speed.
- Easy non-invasive inspection of cylinder components for simple condition-based maintenance.
- Simple overhauls to minimize downtime — Power Assembly (head, liner, piston, rod) can be removed and replaced as one unit in under 4 hours.
- Closed loop dosing control system optimizes Diesel Exhaust Fluid (DEF) usage.
- No oil change required between overhauls unless indicated by oil sample analysis.

Quantifying ownership costs for the purposes of engine selection and budgeting is a challenging task. In order to simplify this process, a Total Cost of Ownership (TCO) report is available for your planning and comparison needs. The analysis considers many factors including:

- Duty-cycle impacts
- Preventative maintenance parts and labor
- Economic factors such as commodity price and inflation
- Labor estimates for all activities.



CATERPILLAR SOLUTIONS/ EMD[®] ENGINES

COMPREHENSIVE SOLUTIONS

As a product in the expansive Caterpillar Marine portfolio, the EMD engine is also available and compatible with many CAT Marine vessel solutions, including:

- CAT Connect technologies such as Marine Asset Intelligence
- SOS oil sampling and analysis services
- Local engine alarm/control panels and remote displays



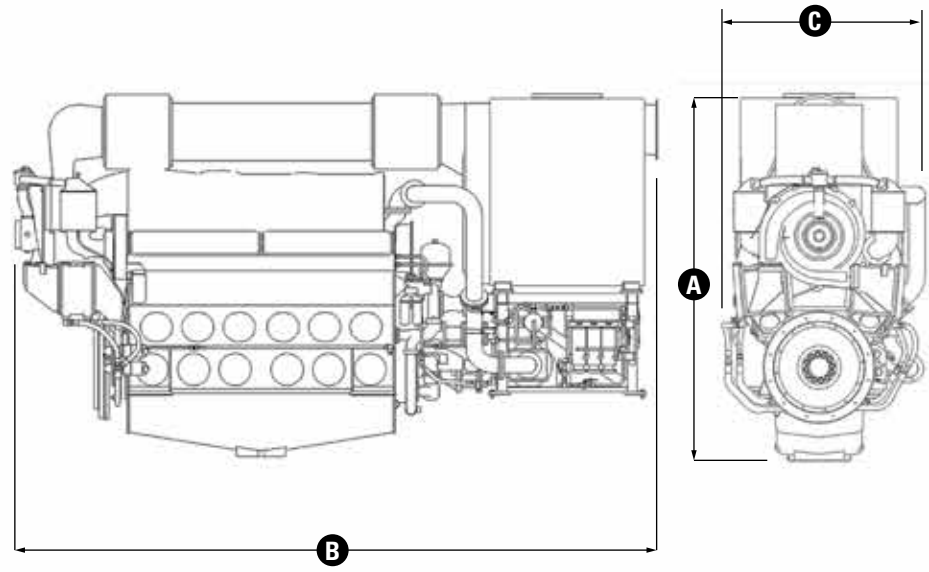

E 23B ENGINE

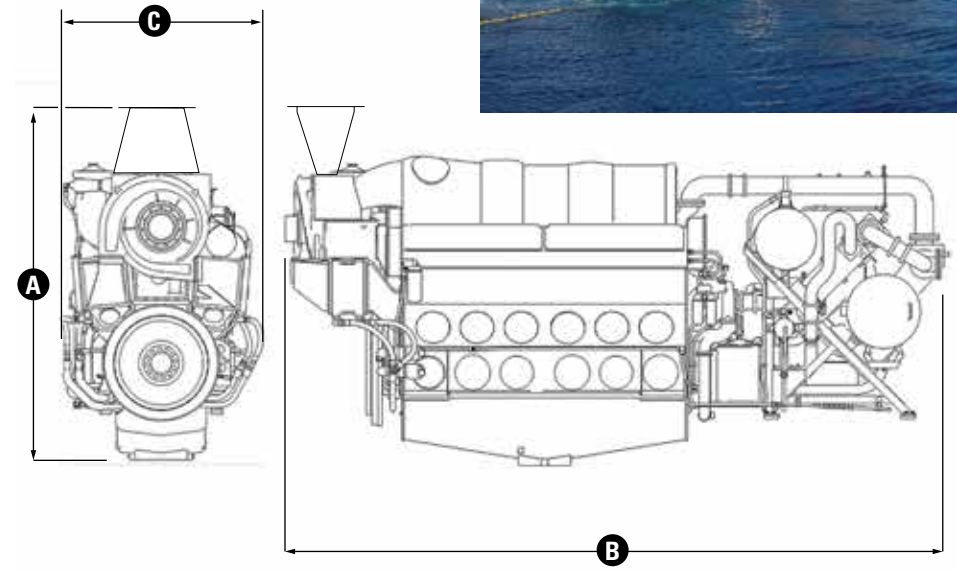

E 23 ENGINE

E 23 / E 23B TECHNICAL SPECIFICATIONS

MARINE ENGINE MODEL	A OVERALL HEIGHT		B OVERALL LENGTH		C OVERALL WIDTH		D WEIGHT WITH ACCESSORY RACK	
	METRIC	US STD	METRIC	US STD	METRIC	US STD	METRIC	US STD
8 E 23	3.246m	10' 7 13/16"	5.374m	17' 7 9/16"	1.943m	6' 4 1/2"	14,387 kg	31,718 lbs
12 E 23	3.410m	11' 2 1/4"	6.350m	20' 10 1/16"	1.943m	6' 4 1/2"	19,414 kg	42,800 lbs
16 E 23	3.410m	11' 2 1/4"	7.332m	24' 11/16"	1.943m	6' 4 1/2"	21,324 kg	47,000 lbs
20 E 23	3.642m	11' 11 3/8"	8.178m	26' 10"	1.943m	6' 4 1/2"	26,027 kg	57,380 lbs
8 E 23B	3.533m	11' 7 1/8"	5.572m	18' 3 3/8"	2.034m	6' 8 1/16"	18,370 kg	40,400 lbs
12 E 23B	3.685m	12' 1 1/16"	6.591m	21' 7 1/2"	2.034m	6' 8 1/16"	23,170 kg	51,100 lbs
16 E 23B	3.685m	12' 1 1/16"	7.548m	24' 9 3/16"	2.034m	6' 8 1/16"	25,243 kg	55,650 lbs

EMD[®] GENERATOR ADVANTAGE

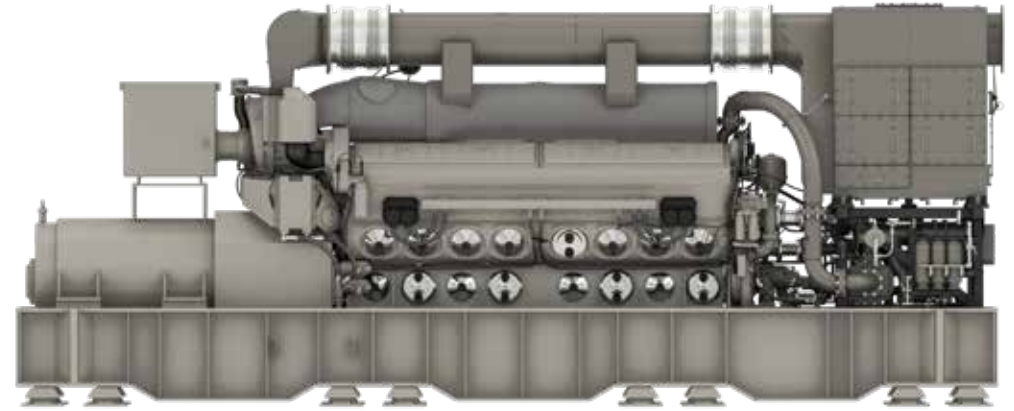

COMPLETE CUSTOMIZED EMD-POWERED GENERATOR SET SOLUTIONS

- Dealer-supplied solutions ranging from standalone generator sets to complete sound-insulated enclosures
- Designed and built to meet marine and stationary electric power contract requirements
- Emergency, Standby, Prime and Unrestricted Continuous Power applications
- Fully integrated and factory-certified EPA Tier 4 offerings

TRANSIENT RESPONSE

- Black start capability – start-to-full power in less than 10 seconds without need for external power boosting
- 100% block load capability
- Simplifies load management, prevents need for load shedding and reduces power plant costs

LOWEST LIFE CYCLE COST

- Reduce fuel consumption, exhaust emissions and noise with variable speed options
- Low bmp diesel engine for highest durability and longest reliability
- Lightweight medium speed genset reduces power plant capital costs
- Capability to convert to natural gas without loss of diesel transient response

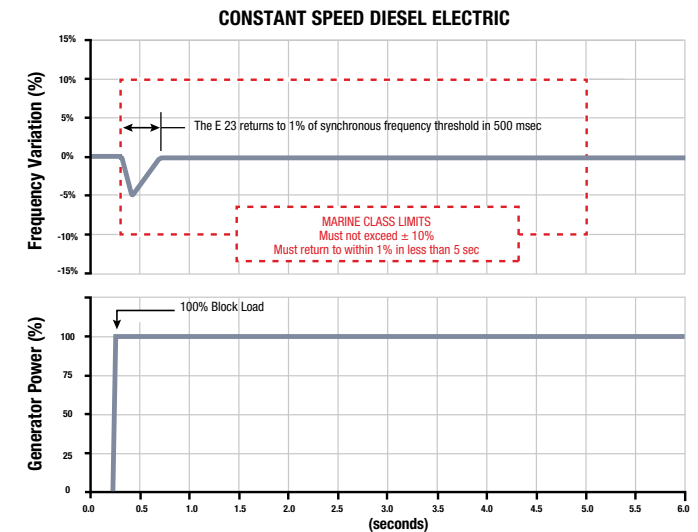



EMD® Marine and Industrial Engines Global Dealer network

Find out more about EMD Marine & Stationary Engines.



Progress Rail

A Caterpillar Company

+1-800-476-8769 | progressrail.com | [@progressrail](https://www.facebook.com/progressrail) | [@Progress_Rail](https://twitter.com/Progress_Rail)

EMD® Engines is a brand of Progress Rail Locomotive Inc.