



**CAT<sup>®</sup> POWER MODULE**  
**C13B & TR43-E44**  
**370 kw / 496 hp**

# INTRODUCING **CAT POWER MODULES FOR RAIL APPLICATIONS**

**Caterpillar OEM Solutions provides electronic and electrical components and systems, which enhance the value of your customers' products.**

**For more than 15 years, we have been providing real-world solutions for the industries we serve.** And now we are offering an integrated power module which includes a Cat® engine coupled with a Caterpillar transmission for the rail industry.

**The Cat C13B Industrial Diesel Engine is offered in ratings ranging from 340-430 kW (456-577 hp) @ 1800-2100 rpm.** These ratings meet EU Stage V, U.S. EPA Tier 4 Final, Japan 2014, Korea Tier 4 Final\*, and China Nonroad IV emission standards.



*\*Korea Tier V Capable*



## **HIGH POWER DENSITY**

- + Up to 20% more power and 19% more torque compared to C13.
- + Exceptional power density enables you to use a smaller displacement engine and optimize the installation in your application.
- + Torque back-up and high torque at low speed delivers outstanding block acceptance.

## **RELIABLE, QUIET, DURABLE POWER THAT MAXIMIZES UPTIME**

- + World-class manufacturing capability and processes coupled with proven core engine and integral transmission designs assure reliability, quiet operation, and many hours of productive life.
- + Caterpillar Industrial Engines and Transmissions have been validated in a wide variety of applications, including Locomotive and Rail.
- + Electronic control systems are proven to withstand severe conditions.
- + Simple, efficient turbochargers deliver top performance.
- + Aftertreatment module enables quieter engine.
- + Same transmissions have been used in Rail industry for more than 15 years.

## **HIGH QUALITY**

- + Cat engines and transmissions are manufactured to stringent standards for customer satisfaction.
- + Superior dealer service network and world-class product support offered through global Cat dealer network.
- + Scheduled maintenance, including S•O•S sample, reduces operating cost.
- + Extended Service Coverage (ESC) and Customer Value Agreements (CVA) available.
- + Core engine platforms deliver long life to overhaul and engines are designed to be remanufactured
- + Available aftertreatment systems for highly regulated models are built to withstand extreme conditions.

## **EASY INSTALLATION**

- + Compact engine aftertreatment and integral transmission and torque converter minimize package size. Ideal for equipment with narrow compartments.
- + Aftertreatment installation flexibility to meet all applications – including remote mount and engine-mounted options from the factory.
- + Low heat rejection levels allow for optimized cooling package at equivalent power.
- + Fully integrated hydraulics, including pumps, hoses, valves and filters, enables easy installation and protects the transmission during dead-engine towing.
- + Flexible transmission oil level gauge installation allows easier routing checks.

## **AFTERTREATMENT FEATURES**

- + Meets EU Stage V, U.S. EPA Tier 4 Final, Japan 2014, Korea Tier 4 Final, and China Nonroad IV emission standards.
- + Clean emissions module (CEM) consisting of diesel oxidation catalyst (DOC) and combined diesel particulate filter (DPF) and high-efficiency selective catalytic reduction (SCR).
- + Maximum uptime with transparent aftertreatment regeneration, without operator distraction or impact to machine performance.
- + PETU DEF capacity up to 93.7 liters (24.7 U.S. gallons).
- + Minimum 5,000 hour service interval for DPF/PETU filters.

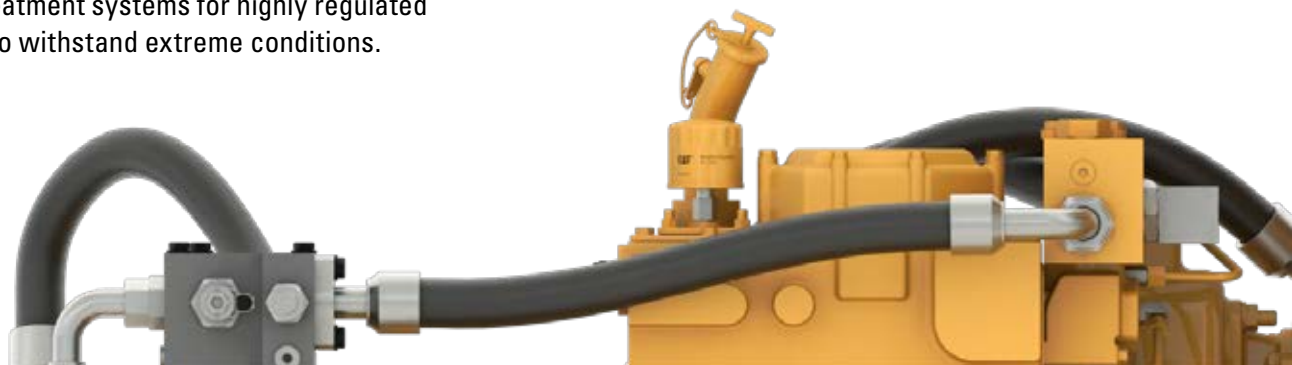

## LOW-COST MAINTENANCE

- + Ideal for high-hour applications over 10,000 hours.
- + Minimum 5000-hour diesel particulate filter (DPF) service interval enables low-cost maintenance.
- + Standard service intervals of 500 hours under normal operating conditions.
- + The S•O•S<sup>SM</sup> program is available from your Cat dealer to optimize oil change intervals.
- + Precise measurement and control enable better fluid efficiency during aftertreatment regeneration.

## FLUID & FUEL EFFICIENCY

- + Caterpillar integration expertise optimizes engine performance for maximum efficiency.
- + Fluid consumption optimized to match operating cycles for a wide range of equipment and applications while maintaining low operating costs.
- + C13B fuel consumption has been improved by up to 6% at equivalent power (BSFC).
- + Engine oil service hours increased from 250 hours to 500 hours (capable of 1000 hours).

## INTEGRATED ENHANCED ELECTRONICS

- + The C13B is equipped for the future with the latest technology from a single on-engine ECM.
- + 2-wire Ethernet connection allows for simpler, faster installation and for remote service and software flash.
- + Transmission ECM available for additional safety and advanced control features:
  - **Automatic or Manual Shift Mode:** Operator can request operation in a specific gear.
  - **Vehicle Speed Limit:** The controller limits vehicle speed to a configurable value.
  - **Traction Control:** Proactively prevents wheel slip from occurring.
  - **Park Brake Control:** Assists in incline start conditions and prevents machine from moving when not powered.
  - **Vigilance/Alerter System:** Safety feature that stops the machine if the operator does not regularly demonstrate alertness.
  - **Dual power control system:** Allows the two machines to operate individually or in dual power mode, with the two machines mechanically and electronically coupled together. Locomotives can be connected in any orientation relative to each other. The controller includes “Master Cab” arbitration.

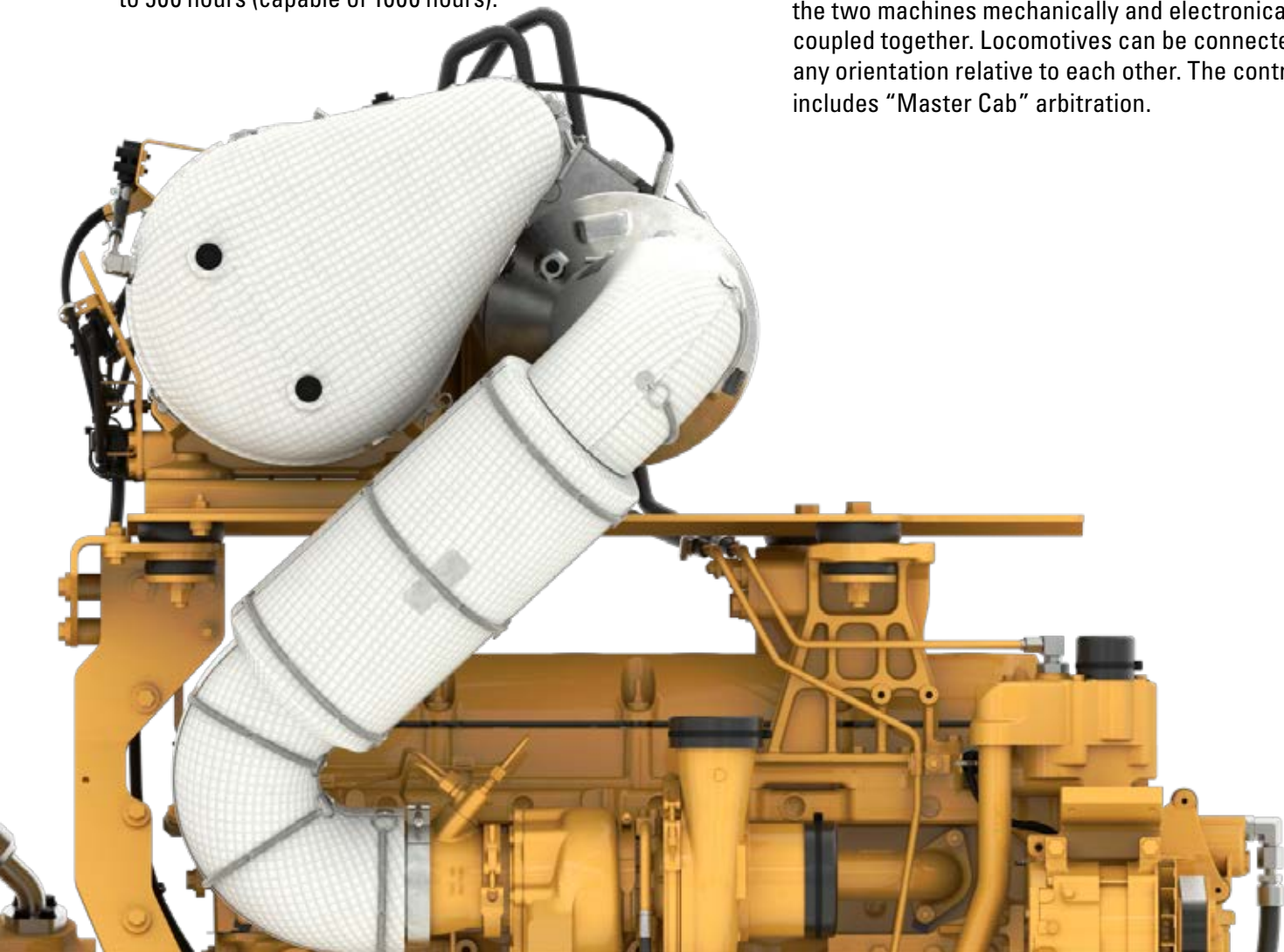

# INTEGRATED ELECTRONIC CONTROL FEATURES

## WITH DUAL POWER CONTROL SYSTEM

Allows the two machines to operate individually or in dual power mode, with the two machines mechanically and electronically coupled together. Locomotives can be connected in any orientation relative to each other. The controller includes "Master Cab" arbitration.

### OPTIMIZED SHIFT POINTS

Shift points are optimized to accommodate various applications.

### CONTROLLED THROTTLE SHIFT

Upon shift, transmission sends a command to bring engine speed to required value expected at end of shift to provide smooth shifts.

### AUTOMATIC OR MANUAL SHIFT MODE

Operator can request operation in a specific gear.

### VEHICLE SPEED LIMIT

The controller limits vehicle speed to a configurable value.

### LIMP HOME MODE

Ability to safely control machine in the presence of serious failure.

### TRACTION CONTROL

Proactively prevents wheel slip from occurring.

### PARK BRAKE CONTROL

Assists in incline start conditions. Prevents machine from moving when not powered.

### NEUTRAL LATCH

Controls engine speed without engaging the transmission in order to charge air systems and warm up hydraulics before traveling.

### VIGILANCE/ALERTE SYSTEM

Safety feature that stops the machine if the operator does not regularly demonstrate alertness.

### GENERATOR MODE

Commands a specific engine speed in order to run an external PTO.



## NEW DISPLAY PLATFORM

Robust Touch Screen with high definition graphics provides a faster response and boot time.

- » Gateway for remote product support
- » Software Updates wirelessly with free Smart Phone or Tablet app
- » Over The Air (OTA) software update and remote into machine capability
- » Machine Configuration can be done on screen vs. ET
- » Capability to configure machine via display (no ET needed)
- » Diagnostic logging and telemetry
- » Service literature available via PDF on display
- » Quick development and change request capability
- » Family of master displays available in sizes of 7" and 10"
- » Fully programmable for use in any machine application as a master controller
- » Full graphical, diagnostic and CAN gateway capability
- » Capacitive Touchscreen interface is offered for interactive, intuitive HMI
- » Available with IP-camera support with secure proprietary IP WiFi communication

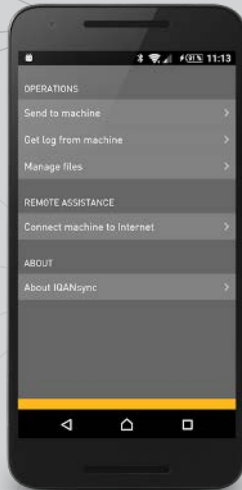

## DISPLAY CONNECTIVITY

- + Bluetooth connectivity and programming via smart phone App.
  - No CAT Comm Adapter needed
- + Smart phone/Tablet App allows remote machine access and datalogging to CAT systems.
  - Available on both Apple or Android system
- + Laptop service tool available via internet download (additional fees).
  - Via Ethernet connector or wireless

## REAL-TIME MONITORING

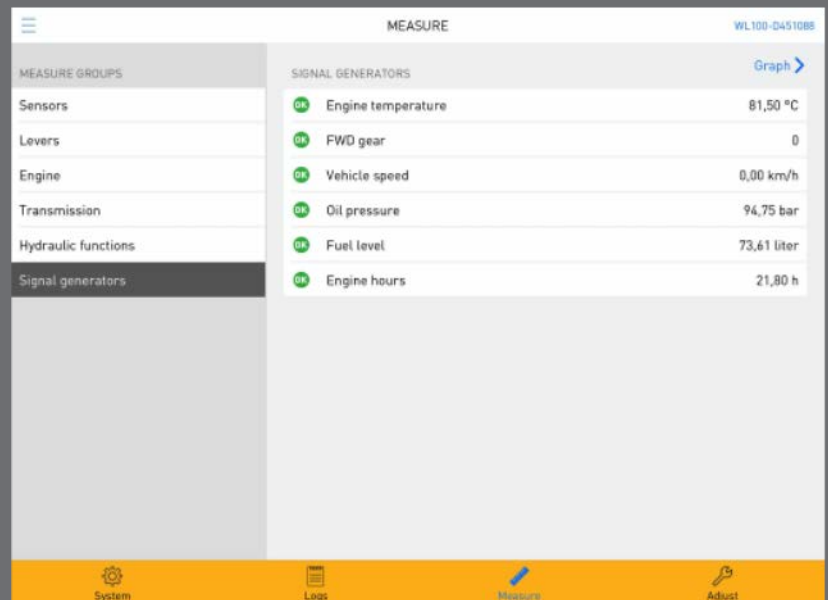

## DIAGNOSTICS

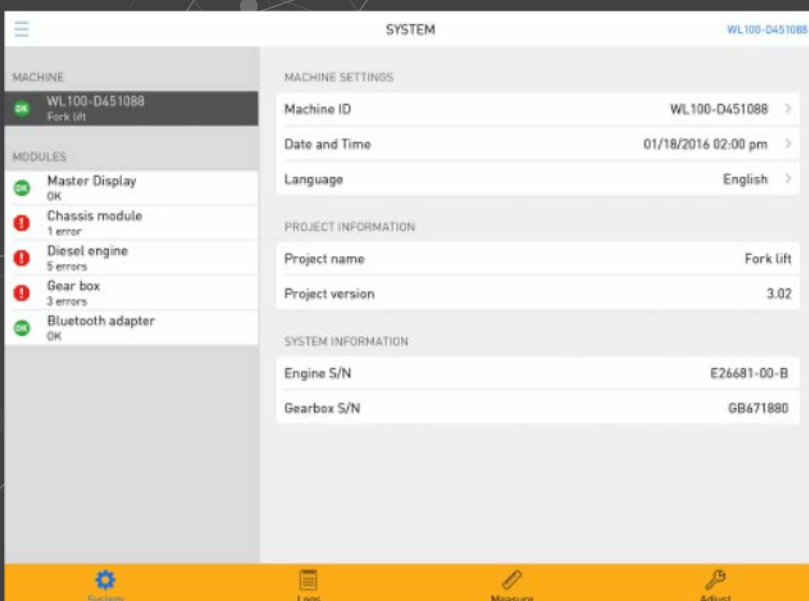

## POWERED BY THE CAT® C13B ENGINE

The Cat C13B Industrial Diesel Engine is offered in ratings ranging from 340-430 kW (456-577 hp) @1800-2100 rpm. These ratings meet EU Stage V, U.S. EPA Tier 4 Final, Japan 2014, Korea Tier 4 Final\*, and China Nonroad IV emission standards.

### POWER RATING

Minimum Power	340 kW	456 hp
Maximum Power	430 kW	577 hp
Rated Speed	1,800-2,100 rpm	

### EMISSION STANDARDS

EU Stage V, U.S. EPA Tier 4 Final, Japan 2014, Korea Tier 4 Final\*, and China Nonroad IV Emission Standards

Performance	UN R120 for measurement of net power and specific fuel consumption
-------------	--

### ENGINE SPECIFICATIONS

Engine Configuration	In-Line 6, 4-Stroke-Cycle Diesel	
Bore	130 mm	5.1 in
Stroke	157 mm	6.2 in
Displacement	12.5 L	762.8 in <sup>3</sup>
Aspiration	Turbocharged Aftercooled (TA)	
Compression Ratio	15.8:1	
Combustion System	Direct Injection	
Rotation (from flywheel end)	Counterclockwise	
Cooling System Capacity (engine)	18.7 L	19.8 qts
Lube System (refill) - varies based on sump/oil pan selection	34-41 L	35.9-43.3 qts

### ENGINE DIMENSIONS (APPROXIMATE. FINAL DIMENSIONS DEPENDENT ON SELECTED OPTIONS.)

Length	1274 mm	50 in
Width	994 mm	39 in
Height	1134 mm	45 in
Weight – Net Dry (Basic Operating Engine Without Optional Attachments)	1125 kg	2,480 lb

### AFTERTREATMENT DIMENSIONS (APPROXIMATE. FINAL DIMENSIONS DEPENDENT ON SELECTED OPTIONS.)

Length	896 mm	35.3 in
Width	807 mm	31.8 in
Height	460 mm	18.1 in
Weight	100 kg	220 lb

\*Korea Tier V Capable



## STANDARD EQUIPMENT

# C13B ENGINE

### Air Inlet System

- » Turbocharged
- » Air-to-Air Aftercooled
- » Front or rear exhaust configurations available

### Control System

- » Electronic control system
- » Over-foam wiring harness
- » Automatic altitude compensation
- » Power compensated for fuel temperature
- » Configurable software features
- » Engine monitoring system SAE J1939 broadcast and control
- » Integrated Electronic Control Unit (ECU)
- » Remote fan control

### Cooling System

- » Vertical or RH thermostat outlet
- » Centrifugal water pump
- » Guidance on cooling system design available through your dealer to ensure equipment reliability

### Flywheels and Flywheel Housing

- » Available SAE No. 1 power take-off with optional SAE B or SAE C power take-off drives
- » Engine power can also be taken from the front of the engine with optional attachments

### Fuel System

- » Mechanical Electronic Unit Injector fuel system (MEUI-C)
- » Primary fuel filter
- » Secondary and tertiary fuel filters
- » Fuel transfer pump
- » Electronic fuel priming

### Lube System

- » Oil cooler
- » Oil filler
- » Lube oil filter
- » Oil dipstick
- » Gear-driven oil pump
- » Choice of front, rear or center sumps
- » Open crankcase ventilation system with fumes disposal (OCV filter system required for EU Stage V certification engines)

### Power Take-off (PTO)

- » SAE B or SAE C power take-off (PTO) drives
- » Engine power can also be taken from the front of the engine on some applications

### General

- » Caterpillar Yellow paint, with optional colors available
- » Vibration damper
- » Lifting eyes

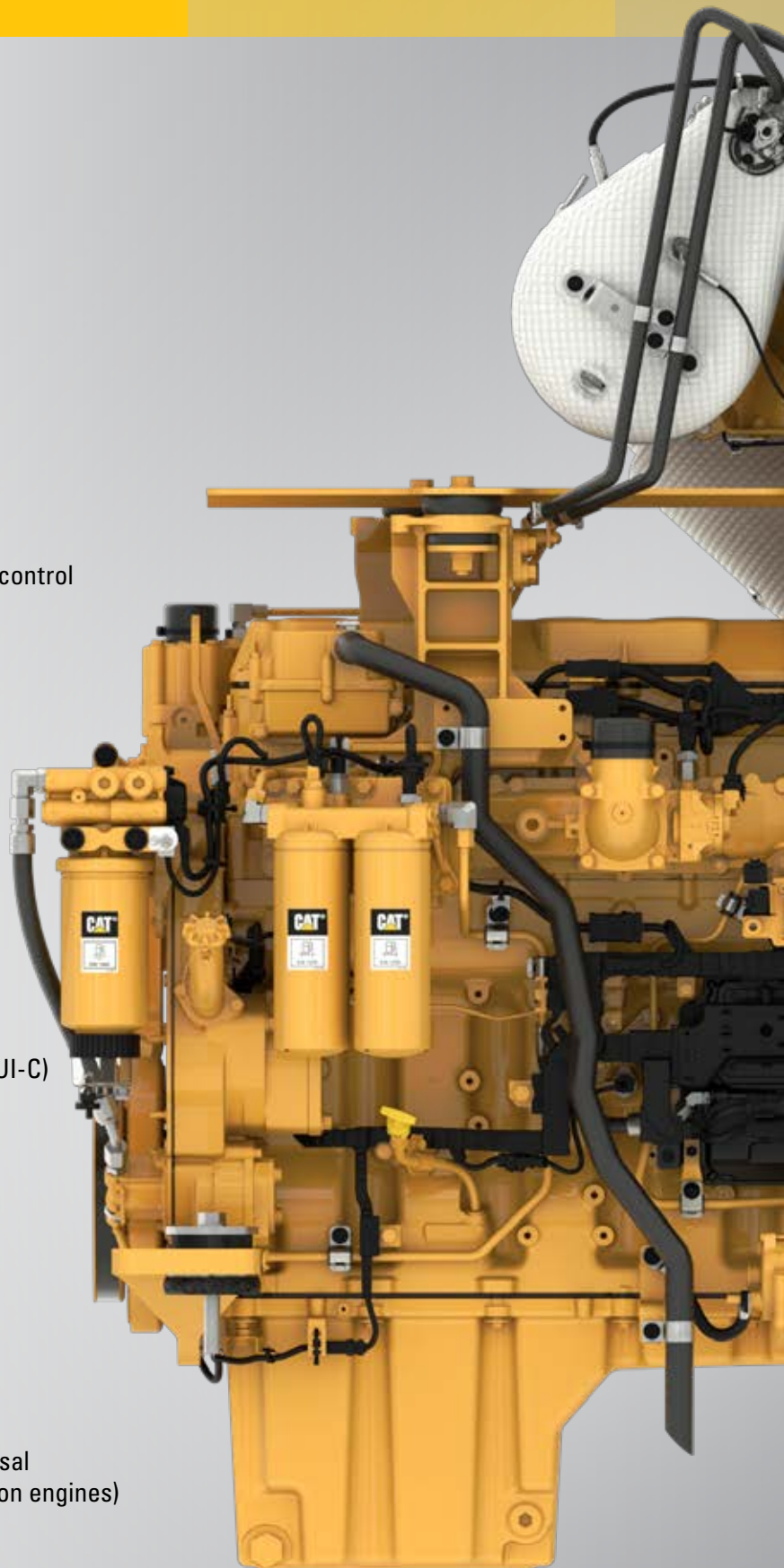

# C13B ENGINE RATING DEFINITIONS AND CONDITIONS

## PERFORMANCE DATA

**IND-A (Continuous)** for heavy duty service where the engine is operated at maximum power and speed up to 100% of the time without interruption or load cycling.

**IND-B** for service where power and/or speed are cyclic (time at full load not to exceed 80%).

**IND-C (Intermittent)** is the horsepower and speed capability of the engine where maximum power and/or speed are cyclic (time at full load not to exceed 50%).

**IND-D** for service where maximum power is required for periodic overloads (time at full load not to exceed 10% of the duty cycle).

**Diesel Engines** – greater than 7.1 liter.

All rating conditions are based on SAE J1995, inlet air standard conditions of 99 kPa (29.31 in Hg) dry barometer and 25°C (77°F) temperature. Performance measured using a standard fuel with fuel gravity of 35° API having a lower heating value of 42,780 kJ/kg (18,390 btu/lb) when used at 29°C (84.2°F) with a density of 838.9 g/L.

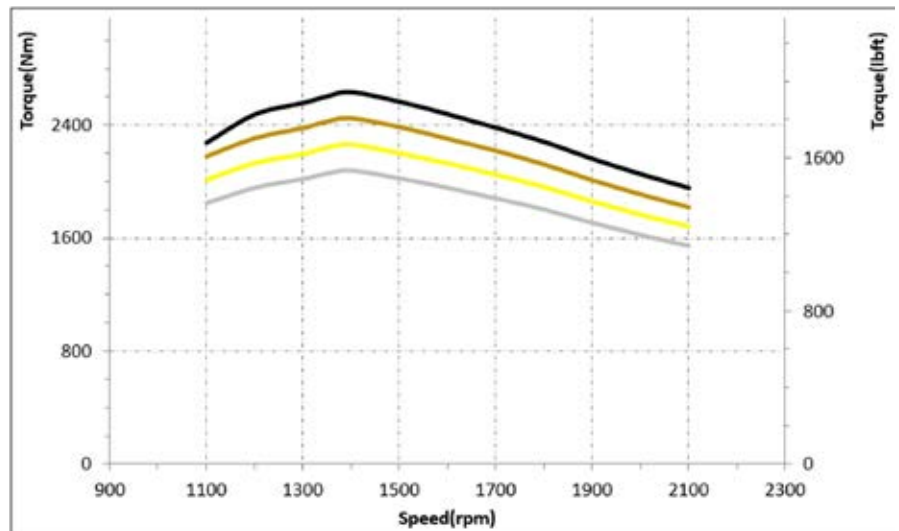
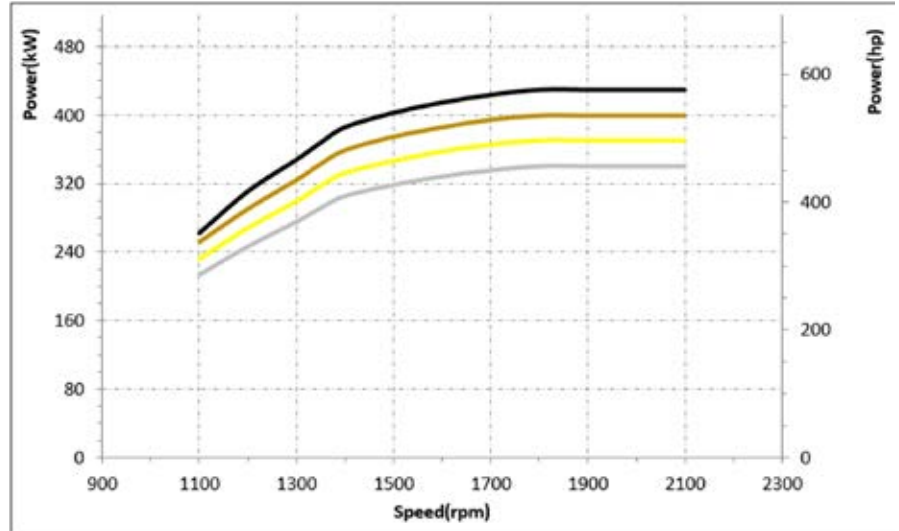

Rating	Aspiration	Rated Speed rpm	Rated Power bkW	Rated Power bhp	Peak Torque N•m	Peak Torque lb-ft	Speed rpm
A	TA	1800-2200	340	456	2082	1536	1400
B	TA	1800-2200	370	496	2266	1671	1400
C	TA	1800-2200	400	536	2450	1807	1400
D	TA	1800-2200*	430	577	2634	1943	1400

\*D Rating available up to 2200 rpm with power and torque as reflected by curves shown.

**MORE POWER, HIGHER TORQUE, LESS SYSTEM WEIGHT  
AND IMPROVED FUEL ECONOMY**

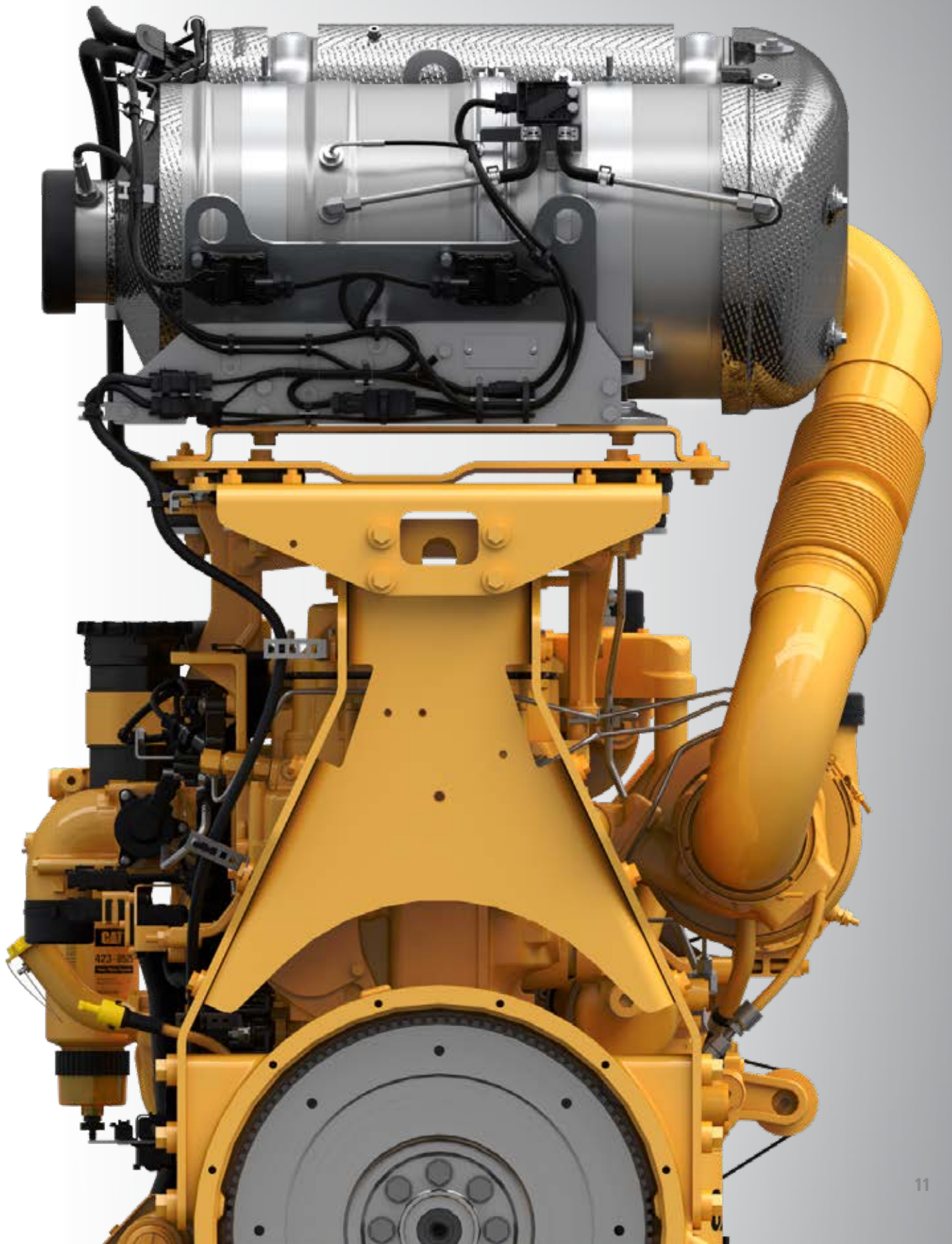

# DRIVEN BY THE CAT TR43-E44 TRANSMISSION

## WITH INTEGRAL TORQUE CONVERTER

### MODEL DESCRIPTION

TR – Transmission, Reversing  
 43 – Clutch Plate Diameter in Centimeters  
 E – Engine-Mount Installation Configuration  
 4 – Number of Forward Gears  
 4 – Number of Reverse Gears

### APPLICATIONS

Typical applications for the TR43-E44 include 2WD or 4WD locomotive, subway and railway applications.

It can also be used by other vehicles that frequently make directional changes during a normal work cycle.

### OPTIONS

Dead Engine Towing Pump

Engine-Mount Configurations Available

### RATINGS

Maximum Input Power	370 kW	496 hp
Maximum Input Torque	2095 N•m	1,545 lb-ft
Maximum Input Speed		2,100 rpm
Minimum Input Speed		700 rpm

### ROTATION

Input Rotation	CCW SAE J824 Standard
Output Rotation	Forward, CCW / Reverse, CW

### CONNECTIONS

Input	SAE #1 Wet Flywheel Housing
Output	Yoke (10C) x 2
Electrical Power	12V or 24V
Electrical Control	1 Bundle
Hydraulic Connections	Oil Cooler and Filter

### CLUTCHES

Electro-Hydraulic Oil Cooled, Multidisc

Clutch Modulation Control	Cat® Electronic Clutch Pressure Control (ECPC)
---------------------------	--

### WEIGHT

Approximate Dry Weight	1489 kg	3,283 lb
------------------------	---------	----------

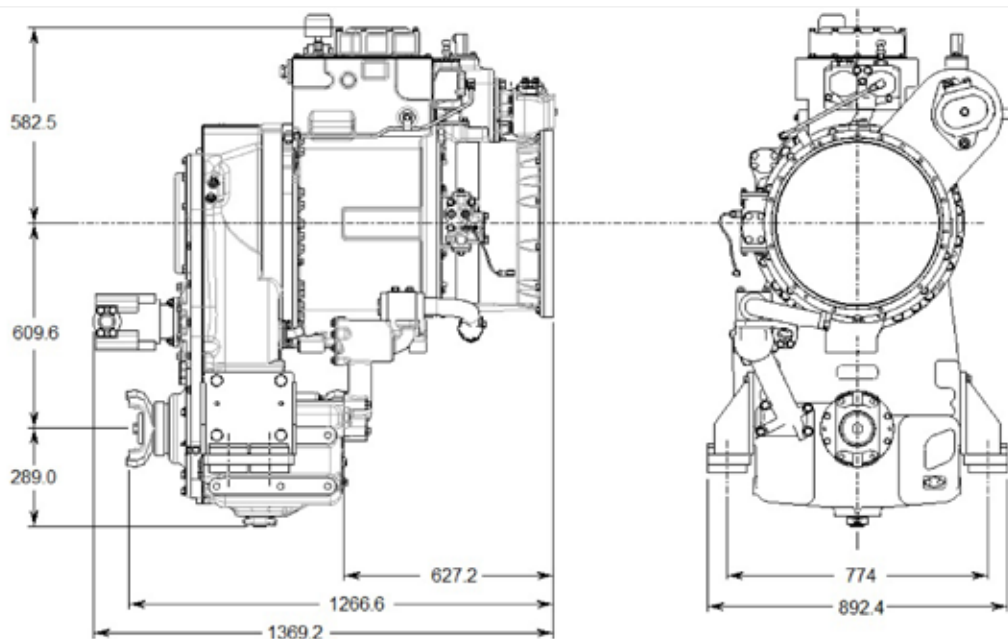

Images shown for reference only  
(shown with Torque Converter)

## TORQUE CONVERTER

Series: TC40 (non-lockup)

### AUXILIARY PUMP DRIVES ON TORQUE CONVERTER (OPTIONAL)

Up to 2 PTOs Integral Live Drive From Input Shaft

Location	2:00 front-facing / 11:00 rear-facing
Mountings	1 Rear-Facing Mounting Pad, SAE "C" 2-bolt flange and 14 tooth spline
Torque Capacity	641 N•m continuous per drive

## OIL SYSTEM

Oil	Transmission/Drive Train Oil-4 (TDTO™)	
Sump Oil Temperatures	Continuous: 95°C (204°F) Max. Intermittent: 116°C (241°F) Max. Converter Outlet Temperature: 124°C (255°F)	
Hydraulic Fill Capacity	83 L	18 gal
Filter Type	8-Micron Paper Cartridge, Remote Mounted	

### GEAR RATIOS (COMBINED PLANETARY AND OUTPUT GEARING)

Forward	1F	6.560
	2F	3.667
	3F	2.060
	4F	1.1667
Reverse	1R	-6.262
	2R	-3.50
	3R	-1.966
	4R	-1.114

# DIMENSIONS

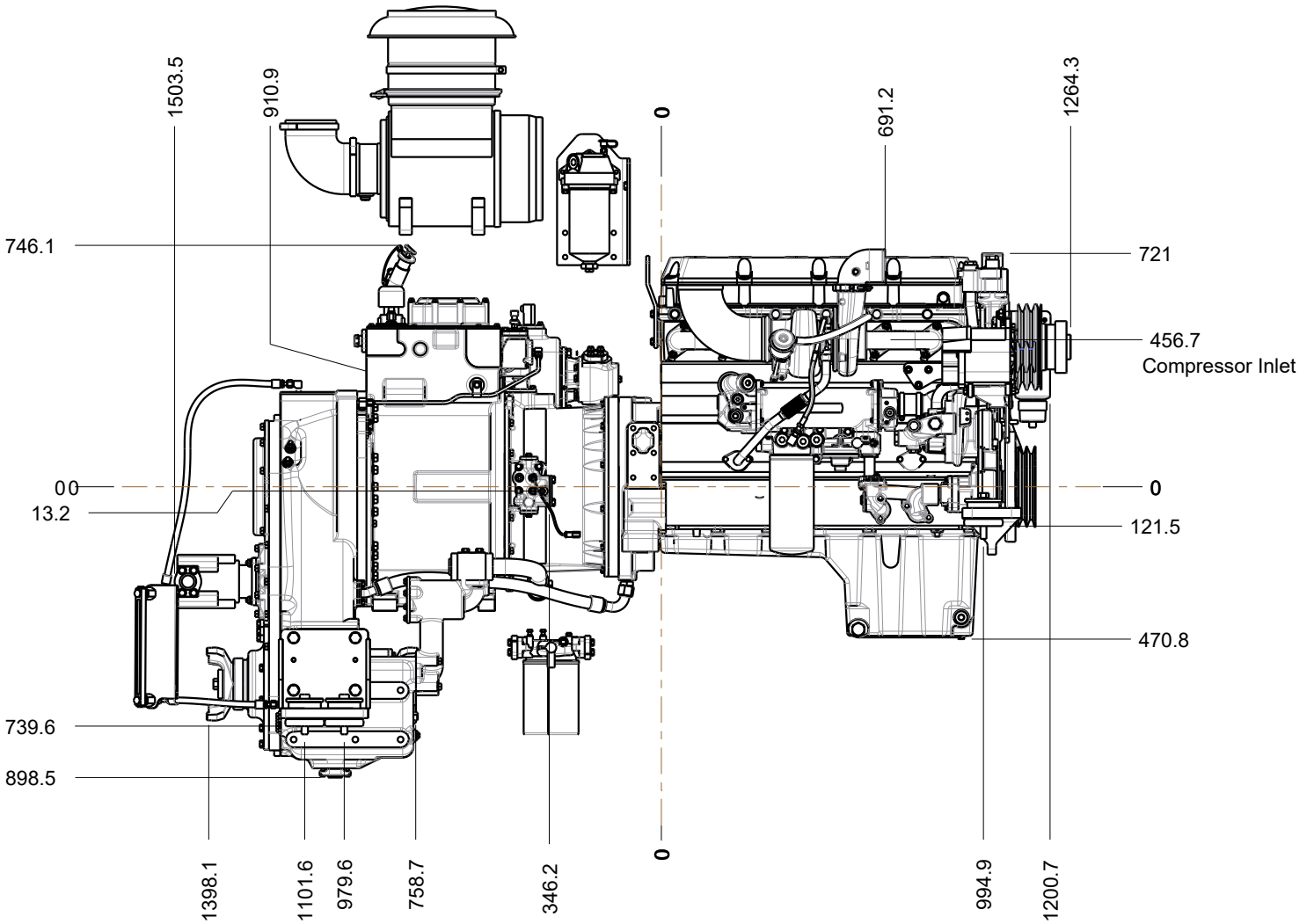
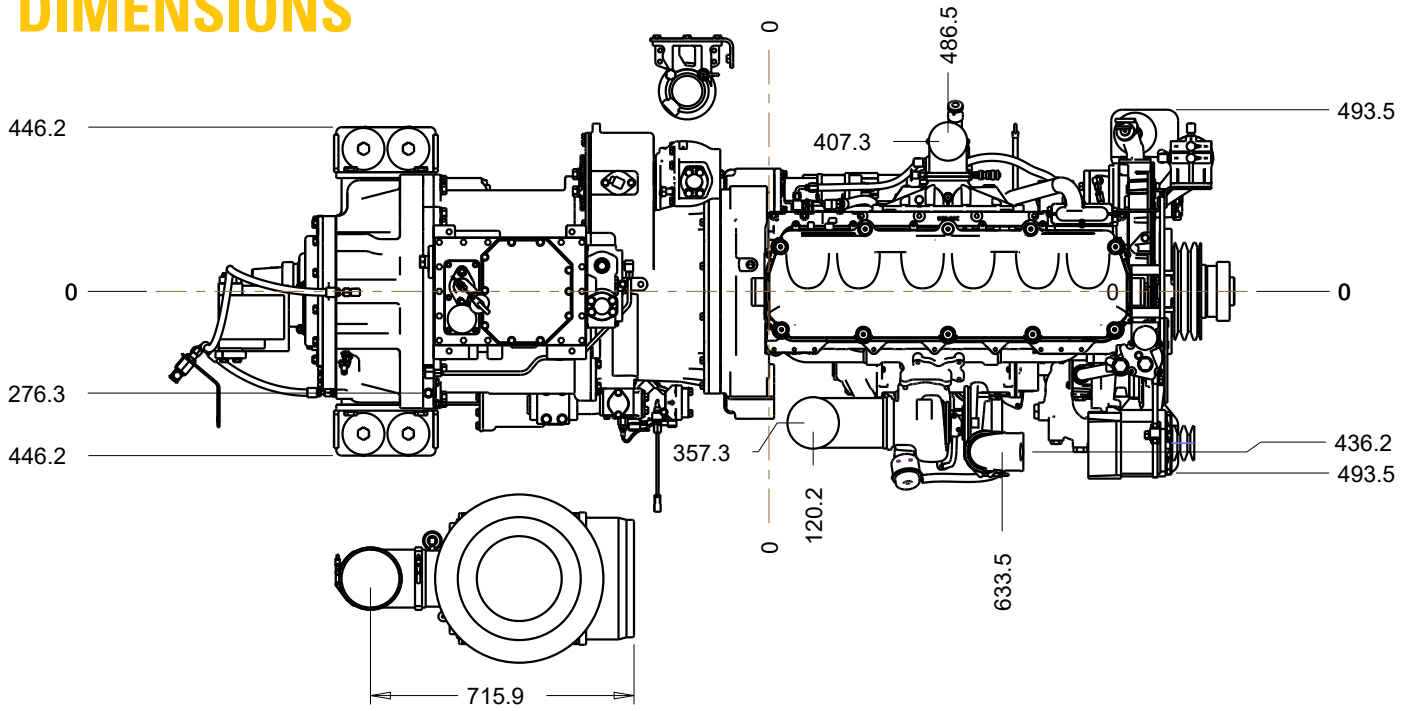





## SERVICE & SUPPORT

# WE'RE PREPARED WITH EVERYTHING YOU NEED.

By supporting your engine and operations, the Cat dealer network protects your relationship with your customers.

- » Market-leading warranty
- » Common service tooling and parts stock coverage
- » Industry-leading parts availability
- » Extended Service Contracts
- » Customer Value Agreements
- » Cat® Financial
- » Reman options and Cat® Certified Rebuild programs

## REMOTE ASSET MONITORING SERVICES THAT MAKE A DIFFERENCE

Combining equipment, technology, and services to help build your success.

### CAT® CONNECT – MORE VALUE, LESS STRESS.

#### Increase Uptime and Reduce Operating Costs

- » Know the location, health, and efficiency of your equipment
- » Advanced Proactive Diagnostics
- » Receive expert recommendations
- » Reduce costs through preventive maintenance, fleet optimization, and equipment lifecycle management

**Now there's an easier way to monitor and manage your assets, no matter where they're located.**

Enroll in Cat Connect Services, and let our expertise turn your data into insights that can improve your profitability.

**To Learn More: [Cat.com/CatConnect](http://Cat.com/CatConnect)**







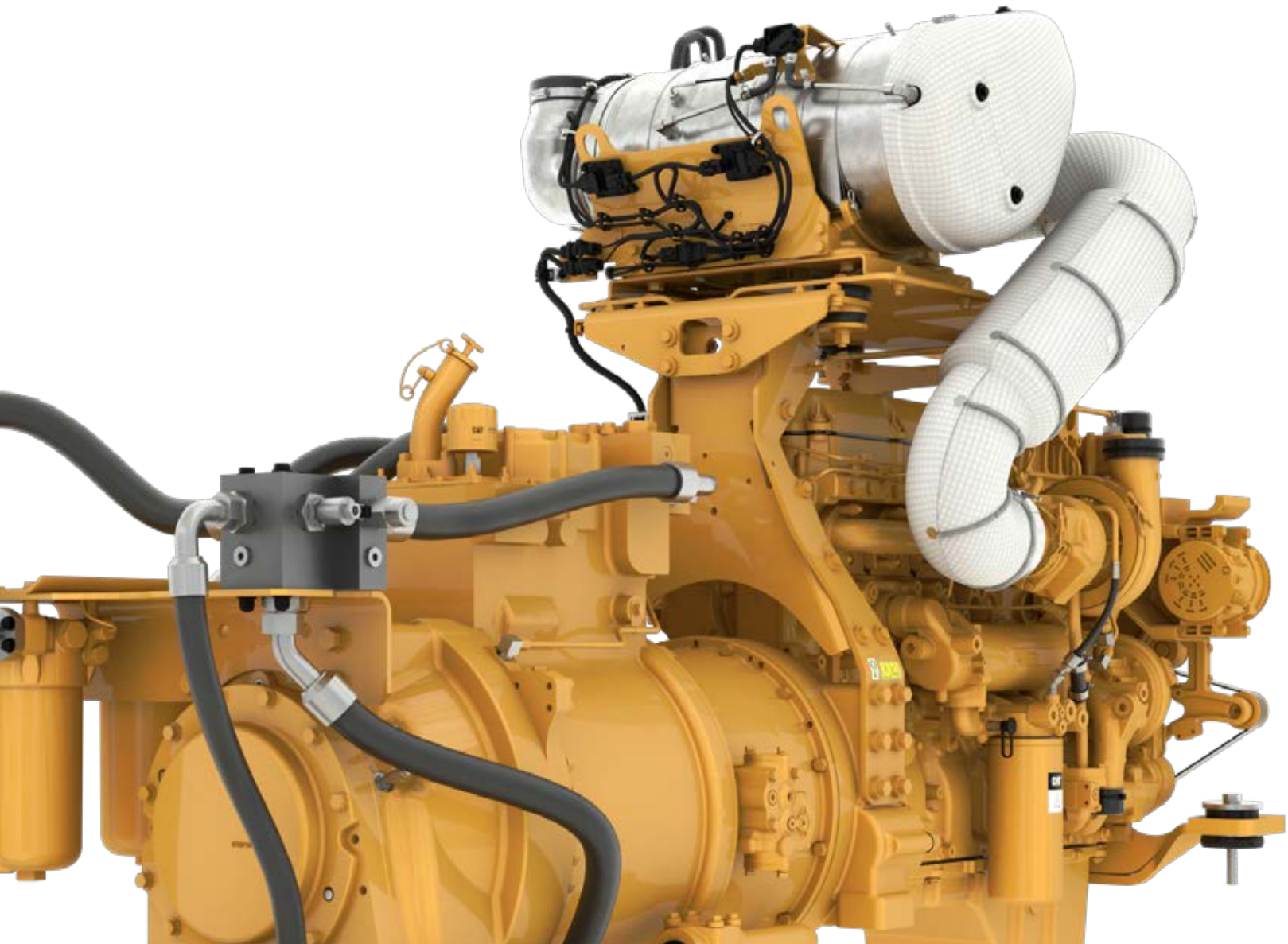

# CAT® POWER MODULES

## C13B & TR43-E44

PEDJ0907 (01-2022)

For more information, contact your OEM Solutions Account Manager or email [oemsolutions@cat.com](mailto:oemsolutions@cat.com)

© 2022 Caterpillar  
All rights reserved

Materials and specifications are subject to change without notice. The International System of Units (SI) is used in this publication.

CAT, CATERPILLAR, LET'S DO THE WORK, their respective logos, "Caterpillar Corporate Yellow," the "Power Edge" and Cat "Modern Hex" trade dress as well as corporate and product identity used herein, are trademarks of Caterpillar and may not be used without permission.

